

Victoria Bridge at Picton

Conservation Management Plan

Roads and Maritime Services | October 2018

ENDORSED
CONSERVATION MANAGEMENT PLAN

Heritage Council



of New South Wales

Date endorsed
15/02/2019

OEH/HC File
SF17/50797



Victoria Bridge at Picton

Conservation Management Plan

Roads and Maritime Services | October 2018

Prepared by Roads and Maritime Services

Copyright: The concepts and information contained in this document are the property of NSW Roads and Maritime Services. In keeping with the NSW Government's commitment to encourage the availability of information, you are welcome to reproduce the material that appears in this Conservation Management Plan for personal, in-house or non-commercial use without formal permission or charge. All other rights are reserved. If you wish to reproduce, alter, store or transmit material appearing in the 'Victoria Bridge at Picton Conservation Management Plan' for any other purpose, a request for formal permission should be directed to Roads and Maritime Services, 20-44 Ennis Road, Milsons Point NSW 2061.

Document controls

Approval and authorisation

Title	Victoria Bridge at Picton Conservation Management Plan
Accepted on behalf of NSW Roads and Maritime Services by:	Sally Durham, Director Environment Regions
Signed:	
Dated:	31/1/19

Executive summary

The purpose of this Conservation Management Plan (CMP) is to guide the conservation and management of Victoria Bridge, ensuring a continuing role and use in the life of the community.

Description of the Item

Victoria Bridge over Stonequarry Creek at Picton is an Allan type timber truss bridge which has been assessed as being of State significance, and is listed on the New South Wales State Heritage Register (SHR). The bridge is located on Prince Street in the township of Picton in the Shire of Wollondilly approximately 82 km southwest of Sydney. The bridge spans a steep valley and is particularly picturesque. Victoria Bridge was constructed by the Department of Public Works in 1897 and is under the care and control of Roads and Maritime Services (Roads and Maritime). The bridge is approximately 80 m long and 6 m wide, consisting of three 90 foot (90' or 27.432 m) Allan type truss spans. The three spans are supported on two timber trestle piers and two timber abutments. The bridge carries a pedestrian footway and a single lane of light traffic with a five tonne posted load limit.

Victoria Bridge is important to the local and regional community, being highly esteemed for its historical value and its contribution to the town's sense of identity as a historical town. It is also of substantial importance for its amenity, providing a vital link for pedestrians, and an important bypass to reduce congestion in the main part of town.

Statement of Significance

Victoria Bridge at Picton is of State significance as an early example of an Allan truss road bridge. As a timber truss road bridge, it has strong associations with the expansion of the road network and economic activity throughout New South Wales, and with Percy Allan (1861-1930), then Chief Draftsman, an eminent engineer, and the designer of this truss type. Allan became Chief Engineer, National and Local Government Works, and made considerable contributions to various engineering institutions both in Australia and overseas. He was awarded a Telford Premium for one of his papers.

Allan trusses were the third in the five-stage development of New South Wales timber truss road bridges. The trusses took advantage of the available high quality NSW hardwoods, known to be among the strongest and most durable in the world. The design is an example of innovative and efficient timber engineering in a time when budgets were tight. The evolution in design shows the growing knowledge of timber as a structural material, the increasing difficulty in obtaining long timbers of large cross-section, and the need for durable and maintainable bridge designs.

The bridge exhibits the technical excellence of its design, as the structural details which distinguish it as an Allan truss are clearly visible, considerably assisted by the designated pedestrian access which has been provided along the length of the bridge from which excellent views can be obtained of almost all of the structural design details. These design details would otherwise be almost impossible to appreciate on a bridge of this scale given the very limited views from off the bridge.

An outstanding feature of Victoria Bridge is the very tall timber trestle piers on which the trusses are supported, the tallest piers of their type in New South Wales. The bridge displays the original colour scheme and largely performs the function for which it was originally designed, which was to carry traffic and pedestrians.

Victoria Bridge is representative at the State level as a fine example of an Allan truss bridge, including all of the principal characteristics of the early 90' Allan truss design, and also due to its integrity to the original

design as an early Allan truss. It is also outstanding due to the esteem in which it is held, particularly by the local community.

Conservation Policies

The following table details conservation policies which apply to Victoria Bridge. All policies that apply to the suite of timber truss bridges across New South Wales are set out comprehensively in the *Overarching Conservation Management Plan (2018)*.

Policy 1	<p>Retention of the cultural significance of Victoria Bridge</p> <ul style="list-style-type: none"> a) Cultural significance of this bridges will be protected or enhanced b) Conservation will be in accordance with the principles of the <i>Burra Charter</i> c) All current and future owners, managers and consent authorities will be advised and jointly responsible for conservation d) Conservation will be done in collaboration with relevant experts
Policy 2	<p>Adoption, implementation and review of the CMP</p> <ul style="list-style-type: none"> a) Roads and Maritime will adopt this CMP b) Roads and Maritime will resource implementation of this CMP c) Roads and Maritime will train relevant staff in the use of this CMP d) Roads and Maritime will make this CMP available to the public e) Roads and Maritime will review this CMP every five years and submit to the Heritage Council for endorsement
Policy 3	<p>Use of the bridge</p> <ul style="list-style-type: none"> a) The continued use of Victoria Bridge as a functioning crossing for vehicles and pedestrians is integral to its cultural significance and survival. New work will be required to adapt to changing transportation needs.
Policy 4	<p>Maintenance and repair</p> <ul style="list-style-type: none"> a) Appropriate ongoing repair and maintenance will be carried out b) Roads and Maritime will prepare an Incident Response Plan for Victoria Bridge c) The bridge will be maintained to support both functionality and form d) The bridge will be regularly inspected by specialists. e) Termites will be inspected for and treated. f) Necessary support structures may be used for maintenance and repair but will be temporary and removed when no longer needed.
Policy 5	<p>New work</p> <ul style="list-style-type: none"> a) Elements will be conserved in accordance with their level of significance b) New works and adaptations may be required to ensure continued operability c) Excellence in design and quality in construction will be provided d) Roads and Maritime will explore and develop the use of new means by which the bridges may continue to fulfil their required functions e) Approvals will be undertaken in accordance with relevant processes

Policy 6	<p>Interpretation</p> <ul style="list-style-type: none"> a) Cultural significance of this bridge will be effectively communicated b) Interpretation of Victoria bridge will be based on the NSW State historical themes and analyses documented in this CMP c) Roads and Maritime will design and install a sign and a plaque an interpretation of a timber bottom chord.
Policy 7	<p>Protection and enhancement of visual setting</p> <ul style="list-style-type: none"> a) Development in the vicinity is to be carefully managed not to have an unacceptable visual impact b) Signage in the vicinity should be minimized c) Vegetation in the vicinity of the bridges should be kept to a minimum d) Relevant planning and statutory controls must be adhered to
Policy 8	<p>Archival recording</p> <ul style="list-style-type: none"> a) Records will be managed to ensure permanent retention as State records b) Photographic archival recording before, during and after any works c) A complete archival recording will be undertaken of Victoria bridge d) Full documentation of methods and materials used during any works e) Representative sample retained as a moveable heritage collection f) Information used to assist effective heritage interpretation of population
Policy 9	<p>Archaeology</p> <ul style="list-style-type: none"> a) Relevant Aboriginal stakeholders will be consulted about any proposed impact b) The Roads and Maritime Cultural Heritage Guidelines and the archaeological provisions of the Heritage Act 1977 will be adhered to. c) The Roads and Maritime Unexpected Heritage Items Procedure will be followed to manage any unexpected finds during works
Policy 10	<p>Exemptions and Approvals</p> <ul style="list-style-type: none"> a) Routine maintenance (Appendix A Table 1) can proceed without notification to the Heritage Council. b) Works identified in Table 2 in Appendix A will need approval/consent advice sought from the Heritage Division regarding the nature/type of approval required prior to works being planned. c) Works identified in Table 3 in Appendix A will need approval in writing from the Heritage Council or delegate.
Bridge Specific Policies	
Policy 11	Top Chords
Policy 12	Bottom Chords
Policy 13	Principals and Diagonals
Policy 14	Tension Rods
Policy 15	Cast Iron Shoes

Policy 16	Sway Braces
Policy 17	Cross Girders
Policy 18	Stringers and Decking
Policy 19	Railing
Policy 20	Piers
Policy 21	Abutments

Bridge Specific Conservation Policies and Conservation Works

In order to adequately demonstrate the strength and durability of the materials or original design, timber truss bridges must remain a vital part of the NSW road infrastructure, which necessitates some elements being modified as transport needs develop. The cultural significance of Victoria Bridge is found primarily in the trusses so it is critical that any work on the bridge does not detract from the interpretation or appreciation of the Allan trusses. Works on the bridge must comply with statutory heritage constraints.

Some of the important conservation management policies specific to the bridge are as follows:

- Victoria Bridge is a place of exceptional cultural significance which will be conserved.
- Victoria Bridge will be maintained and conserved in such a way which protects or enhances the cultural significance of the bridge.
- Conservation of Victoria Bridge will accord with the definitions and principles of *The Burra Charter: the Australia ICOMOS Charter for Places of Cultural Significance 2013*, and include all significant components and attributes of the place and its setting.
- All current and future owners, managers and consent authorities responsible for the care and management of Victoria Bridge and/or its setting will be advised of, and be jointly responsible for, the conservation of the heritage significance of the bridge.
- Victoria Bridge will be used for vehicular traffic. The continued usage of this bridge as a functioning crossing for vehicles and pedestrians is integral to its cultural significance.
- In order to ensure that Victoria Bridge remains in use, it may be necessary to make modifications to the bridge so that it continues to serve the needs of the community.

Contents

Executive summary	i
1. Introduction	1
1.1 Purpose and Scope	1
1.2 Background.....	1
1.3 Overview of Victoria Bridge at Picton.....	2
1.4 Methodology and structure	9
1.5 Contributors	10
1.6 Terminology	10
2. Historical context	15
2.1 The unique hardwood timbers of New South Wales.....	15
2.2 History of early timber bridges in New South Wales.....	18
2.3 History of timber truss bridge design in New South Wales.....	20
2.4 History of the Allan truss	22
2.5 History of the area around Victoria Bridge	40
2.6 History of Victoria Bridge at Picton	47
2.7 Operational Management History	58
2.8 Analysis of the existing fabric.....	71
2.9 Summary of physical condition and heritage integrity.....	107
3. Analysis of significance	109
3.1 Existing statement of significance.....	109
3.2 Comparative analysis.....	109
3.3 Assessment of significance.....	111
3.4 Revised statement of significance	115
3.5 Grading of significant components.....	116
4. Constraints and opportunities	118
4.1 Constraints and opportunities arising from the statement of significance.....	118
4.2 Constraints and opportunities from current listings.....	119
4.3 Constraints and opportunities from operational requirements	124
4.4 Constraints and opportunities from condition and integrity.....	126
5. Development of conservation policies	128
5.1 Current management context	128
5.2 Routine repair works	128
5.3 New work	131
6. Conservation policies	141
6.1 Best practice in heritage management	141
6.2 Ensuring bridges have a role and use in life of communities.....	142
6.3 Interpretation and appreciation of timber truss bridges.....	143
6.4 Documentation and approvals	144
6.5 Bridge Specific Policies	145
7. Implementation of CMP	148

8. References	150
8.1 Books, technical papers and reports.....	150
8.2 Newspaper articles (chronological order)	153
Abbreviations.....	155

Tables

Table 1-1: Summary statutory listing and site identification information	9
Table 2-1: Summary maintenance and repair history of Victoria Bridge	69
Table 2-2: Comparison of the original and existing splice locations for each of the six top chords	75
Table 2-3: Summary of condition of principles and diagonals	81
Table 2-4: Variability in the condition of timber elements	101
Table 2-5: Summary of element condition and integrity	107
Table 3-1: Remaining Allan Truss bridges in NSW	109
Table 3-2: Summary of the grading of significant components.....	116
Table 4-1: Summary of the statutory and non-statutory listings of Victoria Bridge	120
Table 4-2: Summary of relevant provisions of the State-owned Heritage Management Principles (2004)	122
Table 4-3: Summary of relevant provisions of the Heritage Asset Management Guidelines (2004)	122
Table 4-4: Summary of constraints arising from condition and integrity of Victoria Bridge.....	126
Table 5-1: Cyclical maintenance and management activities required for Victoria Bridge	130
Table A-1: Works exempt under s57 of the Heritage Act 1977 not requiring notification to the Heritage Council (Policy 16(a)).....	157
Table A-2: Works that may require Heritage Council approval/consent under s57 or s60 of the Heritage Act 1977 (Policy 16(b)).....	157
Table A-3: Works that are exempt under this Conservation Management Plan in accordance with Standard Exemption 6 under s57 of the Heritage Act 1977 (Policy 16(c)).....	158

Figures

Figure 1-1: Map showing location of Victoria Bridge	2
Figure 1-2: Diagram showing general arrangement of Victoria Bridge.....	3
Figure 1-3:Victoria Bridge in its setting from distance, facing south	3
Figure 1-4: Victoria Bridge in its setting from close up, facing west	4
Figure 1-5: Aerial View of Bridge with locations from which views are seen	5
Figure 1-6: View 1 from Lumsdaine Street through houses and trees	5
Figure 1-7: View 2 from west side of bridge beside height limitation portal.....	6
Figure 1-8: View 3 from east side of bridge after height limitation portals	6
Figure 1-9: View 4 from east side of bridge in clearing beside Prince Street	7
Figure 1-10: View 5 from east side of bridge approaching along Prince Street, showing traffic queuing on western side	7
Figure 1-11: Curtilage Plan.....	8
Figure 1-12: Diagram showing Allan truss terminology from elevation.....	12
Figure 1-13: Diagram showing Allan truss terminology from section.....	12
Figure 1-14: Diagram showing timber abutment terminology from view.....	13
Figure 1-15: Diagram showing timber trestle pier terminology from view	13
Figure 2-1: Forest of young Black-Butt Trees and Tallow-wood Logs for Transport in 1800s.....	15
Figure 2-2: Australian hardwood sleepers and girders being loaded at Darling Harbour for South Africa in 1903	17
Figure 2-3: The laminated timber arch bridge over South Creek at Windsor in 1872.....	19
Figure 2-4: First Timber Truss Bridge in NSW over the Belubula River, Carcoar, 1856	20

Figure 2-5: The timber truss bridge engineers, Bennett, McDonald, Allan, de Burgh and Dare.....	21
Figure 2-6: Percy Allan	23
Figure 2-7: Years employed by PWD and years of construction of truss types.....	24
Figure 2-8: Comparison of Annual Charge for Iron vs Timber Bridges.....	26
Figure 2-9: Rail bridge near Walgett NSW with Allan’s bottom chord splice	27
Figure 2-10: Allan’s Photo of chord testing machine at the Biloela Dockyard	28
Figure 2-11: Comparison of bottom chord connection details	29
Figure 2-12: Sketch of Allan’s proposed 90’ Allan truss	31
Figure 2-13: Comparison of early and later Allan truss bridges.....	32
Figure 2-14: Tharwa Bridge with original wind stays (approximately 1964)	33
Figure 2-15: Early Allan truss with overhead bracing added, undated	33
Figure 2-16: Details of principals and diagonals, Allan’s 1896 design.....	34
Figure 2-17: Original timber deck on Tharwa Bridge, undated	36
Figure 2-18: A Great Load of Wheat: 313 Bags on a Wagon in 1916 (almost 30 tons in total).....	37
Figure 2-19: Original 90’ Allan truss with plan views of top and bottom chords	38
Figure 2-20: Original design of Percy Allan’s Allan truss bottom chord splice.....	39
Figure 2-21: Original design of Allan truss top and bottom cast iron shoes	39
Figure 2-22: Original design of Allan truss shown in section at end of top chord	40
Figure 2-23: Map of The Cowpastures	41
Figure 2-24: 1840s sketch of the Razor Back Road and the original direct line for the Great Southern Road with alteration proposed in favour of Camden	42
Figure 2-25: The main street in 1905.....	43
Figure 2-26: Railway Viaduct at Picton c. 1900	45
Figure 2-27: 1924 Map of the town of Picton showing Victoria Bridge between the former private and government town grids.....	46
Figure 2-28: Flight of steep steps down viaduct wall	48
Figure 2-29: General Arrangement for McDonald’s 1891 Design.....	49
Figure 2-30: General Arrangement for Allan’s 1894 Design.....	50
Figure 2-31: Percy Allan’s design development for metal arch options.....	50
Figure 2-32: Percy Allan’s design development for metal arch options.....	51
Figure 2-33: General Arrangement for Allan’s 1896 Design.....	51
Figure 2-34: View of Picton looking east, 1920	53
Figure 2-35: Victoria Bridge about 1900	54
Figure 2-36: A depiction of Victoria Bridge in The Town and Country Journal 23/03/1901, p 32	54
Figure 2-37: Victoria Bridge as photographed in The Town and Country Journal 8/02/1905, p 31	55
Figure 2-38: Victoria Bridge as photographed in The Town and Country Journal 31/10/1906, p 19.....	55
Figure 2-39: Visitors to Picton pre-WWI	56
Figure 2-40: Plaque for the Bridge	57
Figure 2-41: Vintage Cars on Victoria Bridge	57
Figure 2-42: Self-Guided Tour front cover picture	57
Figure 2-43: 2003 fire damage showing bottom chord damage	58
Figure 2-44: 1948 photographs of Victoria Bridge at Picton	59
Figure 2-45: 2013 photographs of existing Victoria Bridge internal footway.....	59
Figure 2-46: Temporary external footway during 2004 repairs.....	60

Figure 2-47: Signs of failure of embankment beginning in 2003	60
Figure 2-48: Failed abutment and embankment due to slip in 2007.....	61
Figure 2-49: Early photo showing smooth deck, undated.....	63
Figure 2-50: Typical Running Planks on Timber Bridge	64
Figure 2-51: View of existing bolted deck from beneath Victoria Bridge	65
Figure 2-52: Early photograph of Victoria Bridge, undated.....	66
Figure 2-53: Height restriction portals.....	68
Figure 2-54: Safety Warnings, Load Limits and Height restriction portals	71
Figure 2-55: Original 90' Allan truss design with top chords highlighted	74
Figure 2-56: Additional splices at G-H in Span 2 Upstream	76
Figure 2-57: Additional splice at D-E in Span 2 Downstream.....	76
Figure 2-58: Visually dominant “castellated” flashing on top chords	77
Figure 2-59: Original 90' Allan truss design with bottom chords highlighted	78
Figure 2-60: Photograph of timber bottom chord taken from under bridge.....	79
Figure 2-61: Comparison of original and alternative bottom chord splice layout.....	80
Figure 2-62: Original 90' Allan truss design, principals and diagonals highlighted.....	80
Figure 2-63: Photographs of typical deterioration of principals and diagonals, 2017 inspection	82
Figure 2-64: Original 90' Allan truss design with tension rods highlighted	83
Figure 2-65: Photograph of thin nuts and main nuts only partially threaded	84
Figure 2-66: Photograph of unequal (left) and damaged (right) tension rods.....	85
Figure 2-67: Photographs of various cast iron shoes at Victoria Bridge.....	86
Figure 2-68: Original 90' Allan truss design with sway brace locations highlighted.....	87
Figure 2-69: Photographs of upstream sway braces at Victoria Bridge.....	88
Figure 2-70: Photographs of typical condition sway braces	89
Figure 2-71: Original 90' Allan truss design with cross girders highlighted	89
Figure 2-72: Unsightly notching of cross girders at tension rod locations	91
Figure 2-73: Early photo with cross girders, undated	91
Figure 2-74: Photo showing existing non-original long cross girders	92
Figure 2-75: Maintenance monorail attached to underside of cross girders.....	93
Figure 2-76: Unsightly notching of cross girders at bottom chord locations	93
Figure 2-77: Diagram showing original configuration of stringers and deck.....	94
Figure 2-78: Photo of existing stringers and spaced transverse decking	96
Figure 2-79: Bolted and spaced decking	97
Figure 2-80: Photo of existing longitudinal sheeting viewed from above	98
Figure 2-81: Guardrail.....	99
Figure 2-82: Diagram showing original design details for timber trestle piers	100
Figure 2-83: Photographs of condition of concrete bases at piers	102
Figure 2-84: Diagram indicating extent of scour from 2016 flood	103
Figure 2-85: Steep embankment due to scour	103
Figure 2-86: Timber double trestle piers at Victoria Bridge	104
Figure 2-87: Diagram showing original design details for timber abutments	105
Figure 2-88: Photograph of Victoria Bridge Abutment A downstream side	106
Figure 2-89: Victoria Bridge Abutment A upstream side.....	107
Figure 4-1: Detour.....	124

Figure 5-1: Original design for 90' Allan trusses at Swan Hill 132

Figure 5-2: Five Day Creek Bridge (since demolished) with concrete bridge 133

Figure 5-3: Styx River Bridge with visually intrusive new concrete bridge..... 134

Appendices

Appendix A	Schedule of Conservation Works
------------	--------------------------------

1. Introduction

1.1 Purpose and Scope

Roads and Maritime is responsible for the operation and maintenance of Victoria Bridge. When planning for maintenance and ongoing use, the heritage significance both of this particular bridge and its contribution to the overall population of timber truss bridges must be considered.

This CMP identifies the heritage significance of Victoria Bridge and provides conservation policies and strategies to ensure its ongoing use.

The CMP:

- Understands the heritage item through investigation of the history of Victoria Bridge in its setting, its associations, its aesthetic and technical attributes, its importance to the community, its rarity and representativeness as well as its research potential.
- Describes how the bridge was modified over time.
- Provides a statement of significance by analysing documentary and physical evidence.
- Examines constraints and opportunities for conservation, including the requirements of Roads and Maritime to maintain the operability and ongoing use of the bridge.
- Develops conservation policies, arising out of the assessment of significance, to ensure the retention of the heritage significance and develops strategies to manage the significance.

1.2 Background

In 2010, Roads and Maritime prepared *Timber Truss Road Bridges – A Strategic Approach to Conservation* (the Strategy).¹ The Strategy detailed a methodology for assessing the conservation suitability and approach to managing the (then) 48 remaining timber truss bridges managed by Roads and Maritime listed on the SHR and Roads and Maritime's s170 register. The final version of the Strategy was endorsed by the NSW Heritage Council in August 2012.²

The Strategy requires that Roads and Maritime develop conservation planning documentation to set out how individual bridges are to be managed and how the overall heritage values of the retained population will be conserved. Roads and Maritime has committed to the development of a framework of conservation documents including an Overarching Conservation Management Plan (OCMP) and Conservation Management Plans (CMP) for each bridge to be retained under the Strategy. The OCMP encompasses the full population of timber truss bridges, guiding the conservation and management of the bridges to be retained into the future with a continuing role and use in the life of communities. It establishes the heritage significance of the population and sets out policies that apply to all bridges. It was prepared and endorsed in February 2018. Individual CMPs provide any relevant additional item level description and context, provide an analysis of the significance of the specific bridge and set out bridge specific policies and exemptions.

¹ Roads and Traffic Authority (now Roads and Maritime Services), *Timber truss road bridges – A strategic approach to conservation*, July 2011, RTA/Pub.11.267, ISBN 978-1-921899-49-2

² Futurepast Heritage Consulting P/L and NSW Roads and Maritime, *Timber Truss Bridge Conservation Strategy, Submissions report and revised conservation strategy*, July 2012

1.3 Overview of Victoria Bridge at Picton

Victoria Bridge over Stonequarry Creek at Picton is an Allan type timber truss bridge which has been assessed as being of State significance, and is listed on the New South Wales State Heritage Register (SHR). The bridge is located on Prince Street in the township of Picton in the Shire of Wollondilly, approximately 82 km southwest of Sydney. The bridge spans a steep valley and is particularly picturesque.

Victoria Bridge was constructed by the Department of Public Works in 1897 and is under the care and control of Roads and Maritime Services (Roads and Maritime). The bridge is approximately 80 m long and 6 m wide, consisting of three 90 foot (90' or 27.432 m) Allan type truss spans. The three spans are supported on two timber trestle piers and two timber abutments. The bridge carries a pedestrian footway and a single lane of light traffic with a five tonne posted load limit.

1.3.1 Location and Site Identification

Victoria Bridge is located in the town of Picton, south west of Sydney (Figure 1.1).

For the purpose of this CMP the place consists of the bridge with its curtilage, and a visual setting and context, which includes surrounds and the historical crossing.

Figure 1-1: Map showing location of Victoria Bridge

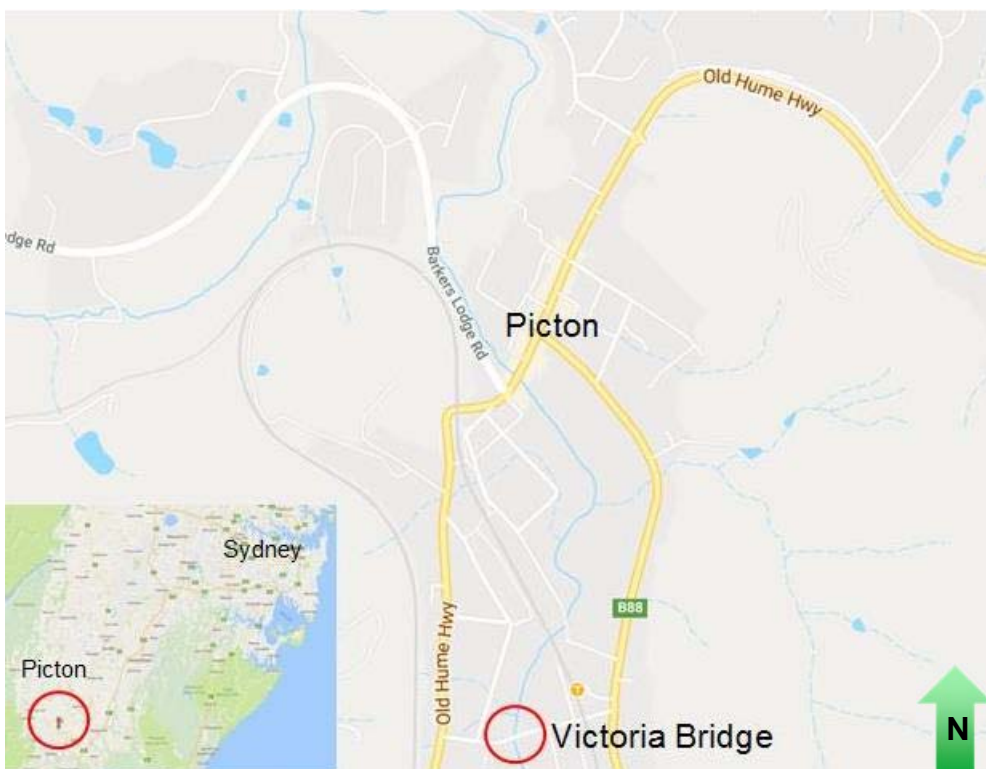

Source: Google Maps

The bridge consists of three 90' (27.432 m) truss spans and is approximately 80 m in length. The bridge has a total width of approximately 6 m and was designed to carry a single lane of traffic. The three spans are supported on timber trestle piers and timber abutments. Due to the poor condition of the one abutment, a large number of temporary props have been added. A comprehensive investigation and identification of the existing fabric is given in Section 2.8.

Figure 1-2: Diagram showing general arrangement of Victoria Bridge

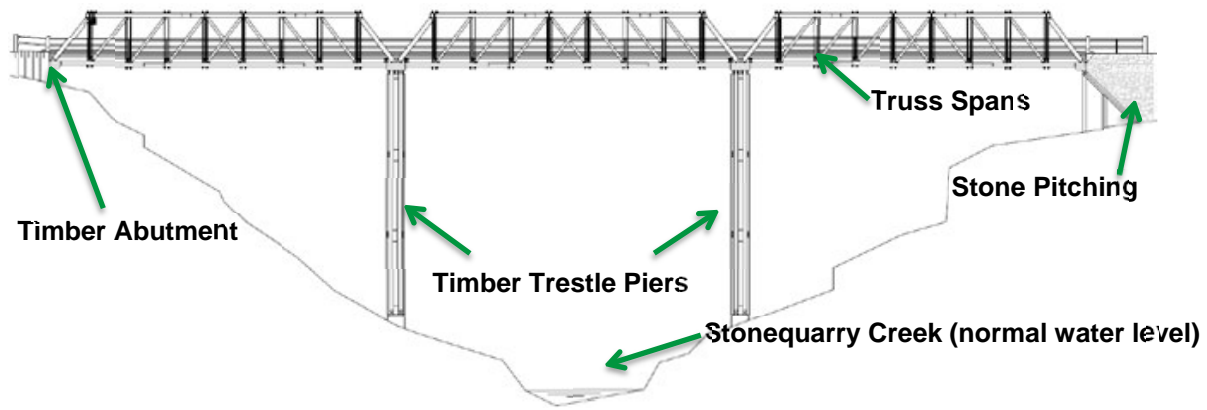

Source: Amie Nicholas

1.3.2 Visual setting and context

Figure 1-3: Victoria Bridge in its setting from distance, facing south



Source: RMS Timber Truss Bridge Conservation Strategy

Figure 1-4: Victoria Bridge in its setting from close up, facing west



Source: Nicholas 2017

1.3.3 The Bridge

As noted in the Strategy,

The bridge spans a steep river valley and is particularly picturesque. It illustrates the fine lines of the truss design particularly well, shown to good effect in the original white colour scheme. There are opportunities for interpretation at viewing locations. The masonry lined embankments add interest to the structure which links to contemporary structures in the historic township of Picton, enabling it to be meaningfully read and appreciated as part of a cultural landscape, in addition to being associated with a broader history of settlement.³

Victoria Bridge is situated within a residential part of the township at Picton. Views from the creek which were so popular when the bridge first opened are obstructed by residences and vegetation. Furthermore, views of the bridge along the road are obstructed by the height restriction portals that are located at either end of the bridge.

There are currently very few good views towards the bridge. There are excellent views of the trusses while crossing the bridge, either as a pedestrian or in a vehicle, but views of the piers and abutments are very limited. Some of the more prominent and important views of the bridge are shown in Figures 1.5 to 1.10.

³ Roads and Traffic Authority (now Roads and Maritime Services), *Timber truss road bridges – A strategic approach to conservation*, July 2011, RTA/Pub.11.267, ISBN 978-1-921899-49-2, appendix 1C, pp 11-12.

Figure 1-5: Aerial View of Bridge with locations from which views are seen



Source: Google Maps

Figure 1-6: View 1 from Lumsdaine Street through houses and trees

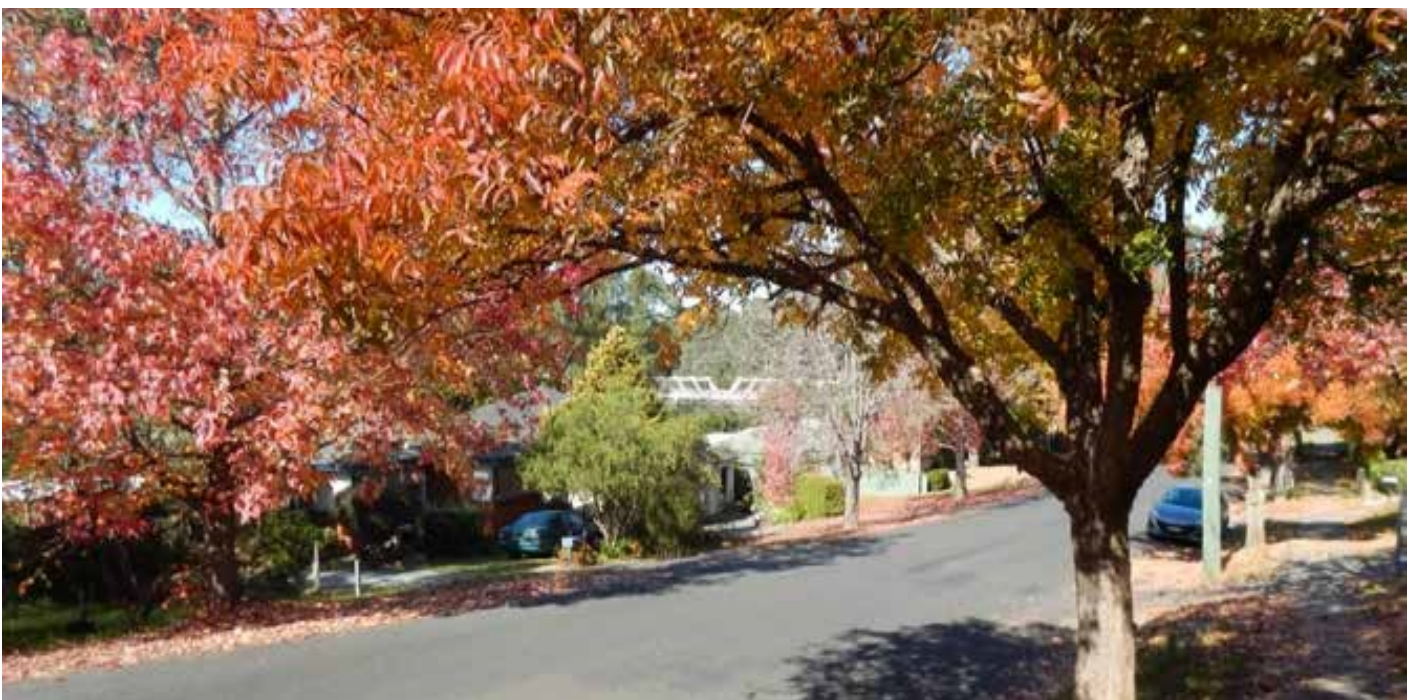

Source: Amie Nicholas 2017

Figure 1-7: View 2 from west side of bridge beside height limitation portal



Source: Nicholas 2017

Figure 1-8: View 3 from east side of bridge after height limitation portals



Source: Nicholas 2017

Figure 1-9: View 4 from east side of bridge in clearing beside Prince Street



Source: Amie Nicholas 2017

Figure 1-10: View 5 from east side of bridge approaching along Prince Street, showing traffic queuing on western side



Source: Amie Nicholas 2017

1.3.4 The curtilage

Victoria Bridge is listed on the SHR, and has a slightly enlarged curtilage as indicated in Figure 1.11.

The heritage curtilage for Victoria Bridge at Picton is a horizontal buffer extending ten metres back from the termination of the bridge deck at each end of the bridge and eleven metres from the edge of the bridge on either side. The curtilage also extends in space above and below deck level. This is contiguous with the SHR listing boundary and this curtilage remains suitable.

Figure 1-11: Curtilage Plan

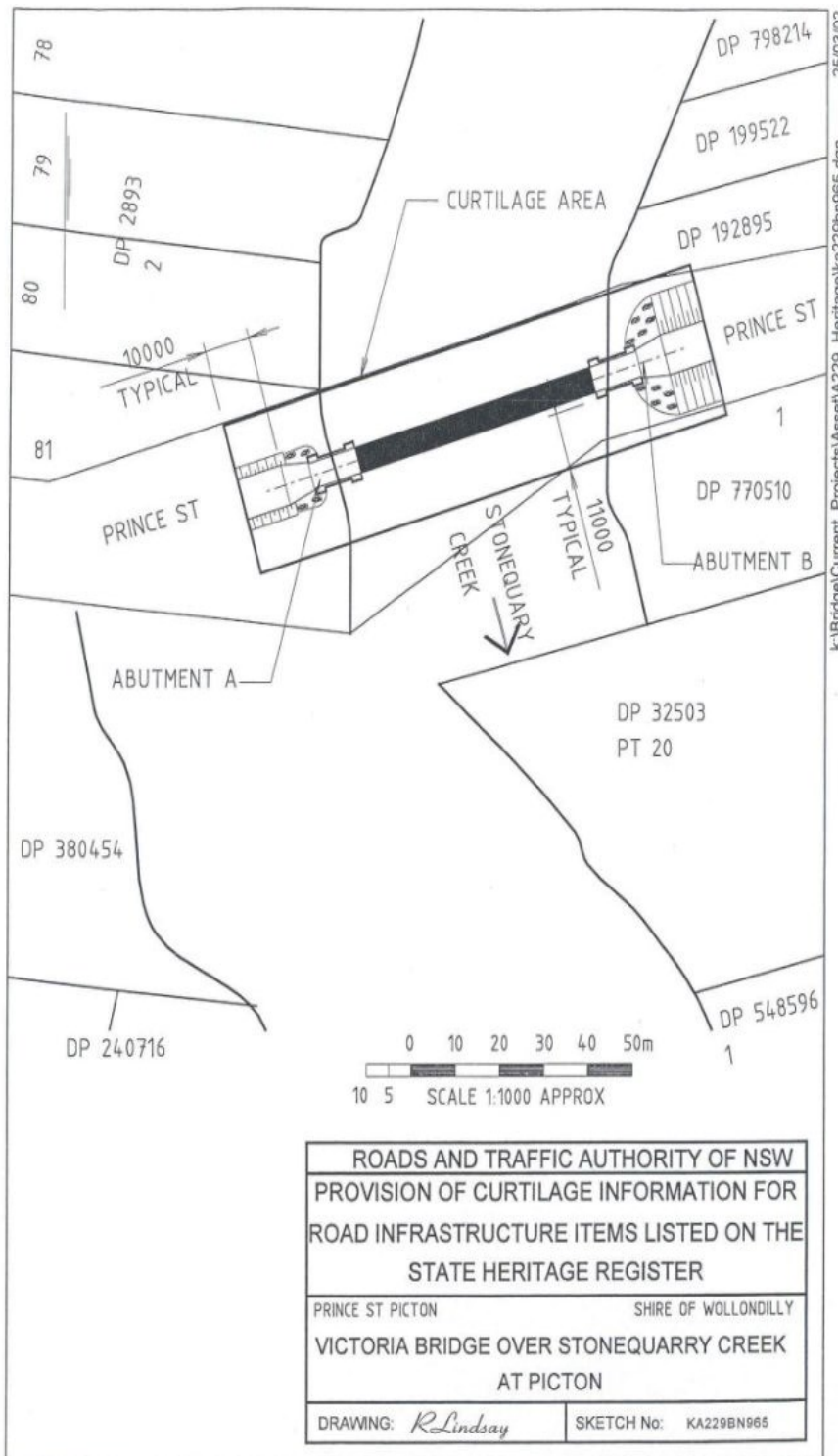

Source: SHR Listing

1.3.5 Statutory Listings

Table 1-1: Summary statutory listing and site identification information

State Heritage Register name and number	Victoria Bridge over Stonequarry Creek 01484
Roads and Maritime s170 number	5051388
Wollondilly Shire Council Local Environmental Plan (LEP) 2011	Item number I206 - Victoria Bridge Victoria Bridge is also included within the Picton Heritage Conservation Area, identified in the Picton Heritage Conservation Area in the Wollondilly LEP 2011
Alternate / locally used names	Victoria Bridge at Picton
Roads and Maritime Bridge number	965
Road name	Prince Street
Coordinates [centre point] – latitude / longitude	Lat: -34.1802850944 Long: 150.6107123840
Local Government Area	Wollondilly
Roads and Maritime Services region	Southern

1.4 Methodology and structure

The primary purpose of a CMP is to establish policies which will guide the future care and development of a place.⁴ This report has been prepared according to the methodology recommended by the Heritage Division of the NSW Office of Environment and Heritage (OEH) in *Assessing Heritage Significance*, and is consistent with the guidelines set out in the Australia ICOMOS Burra Charter, 2013 (*Burra Charter*) and in the Conservation Plan.⁵

Cultural significance is defined in the *Burra Charter* as aesthetic, historic, scientific, social or spiritual value for past, present or future generations.⁶ In order to manage the bridge in a way that will conserve significance, it is necessary to understand why it is considered significant. Identifying the heritage significance of an item relies on understanding and analysing documentary and physical evidence, the context and historic themes that apply, the ways in which the item's existing features demonstrate its functions and associations, and its aesthetic qualities.

A site inspection was undertaken on Wednesday 17th June 2017 to examine the current condition and integrity of the bridge. Historical research was undertaken making use of previous reports (draft CMP dated

⁴ James Semple Kerr, *Conservation Plan*, 7th edition, National Trust of Australia (NSW), January 2013, p 22.

⁵ *Assessing Heritage Significance*, NSW Heritage Manual, NSW Heritage Office, 2001; *Burra Charter*, 2013; James Semple Kerr, *Conservation Plan*, 7th edition, National Trust of Australia (NSW), January 2013.

⁶ The *Burra Charter*: The Australia ICOMOS Charter for Places of Cultural Significance, 2013

September 2003, research papers and options reports) where applicable, but also undertaking further research through the services of a local historian as well as Roads and Maritime archives and the online resources of the State and National libraries.⁷

This CMP aligns with the structure of Overarching Conservation Management Plan. The format and structure of this report follows the Roads and Maritime template, which in turn follows the lines of the OEH suggested table of contents for a CMP and includes the following:⁸

- A historical investigation seeking to understand the bridge and its setting from available documentary and physical evidence (chapter 2)
- An assessment and statement of significance considering the documentary and physical evidence against the seven criteria outlined in the NSW Heritage Manual (chapter 3)
- An analysis of the constraints and opportunities arising from both the heritage significance of the bridge and the operational requirements for the bridge (chapter 4)
- An investigation into a range of conservation options, taking into account the current condition, the ongoing maintenance requirements, other requirements imposed by external factors (such as legislation) and a range of strategies to provide for the safe ongoing use of the bridge while maintaining or enhancing the heritage value (chapter 5)
- Conservation policies for the bridge (chapter 6)

1.5 Contributors

This CMP has been prepared by Amie Nicholas, Roads and Maritime, Chartered Heritage and Conservation Engineer (Structural), BE, Grad Dip (PM), M.E., M.Herit.Cons., MIEAust, CPEng. Historian Elizabeth Villy prepared an overview of the bridge's historical development.

1.6 Terminology

The terminology in this report is consistent with the definitions given in the *Burra Charter 2013* (copied in full below) with bridge-specific terminology as defined in Section 1.6.2 and Figures 1.12 to 1.15.

1.6.1 Burra Charter definitions

Place means a geographically defined area. It may include elements, objects, spaces and views. Place may have tangible and intangible dimensions.

Cultural significance means aesthetic, historic, scientific, social or spiritual value for past, present or future generations. Cultural significance is embodied in the place itself, its fabric, setting, use, associations, meanings, records, related places and related objects. Places may have a range of values for different individuals or groups.

Fabric means all the physical material of the place including elements, fixtures, contents and objects.

Conservation means all the processes of looking after a place so as to retain its cultural significance.

⁷ In July 2003 a CMP was completed for Clarence Town Bridge and forwarded to the NSW Heritage Office for endorsement. A draft CMP for Victoria Bridge at Picton was commenced by GHD Pty Ltd and Austral Archaeology Pty Ltd using Clarence Town as a template and though this was never completed (latest draft dated September 2003), it contains useful historical information referenced in this current CMP.

⁸ 'A Suggested Table of Contents for a Conservation Management Plan that can be Endorsed by the NSW Heritage Council', Heritage Division of the New South Wales Office of Environment and Heritage, July 2002.

Maintenance means the continuous protective care of a place, and its setting. Maintenance is to be distinguished from repair which involves restoration or reconstruction.

Preservation means maintaining a place in its existing state and retarding deterioration.

Restoration means returning a place to a known earlier state by removing accretions or by reassembling existing elements without the introduction of new material.

Reconstruction means returning a place to a known earlier state and is distinguished from restoration by the introduction of new material.

Adaptation means changing a place to suit the existing use or a proposed use.

Use means the functions of a place, including the activities and traditional and customary practices that may occur at the place or are dependent on the place.

Compatible use means a use which respects the cultural significance of a place. Such a use involves no, or minimal, impact on cultural significance.

Setting means the immediate and extended environment of a place that is part of or contributes to its cultural significance and distinctive character.

Related place means a place that contributes to the cultural significance of another place.

Related object means an object that contributes to the cultural significance of a place but is not at the place.

Associations mean the connections that exist between people and a place.

Meanings denote what a place signifies, indicates, evokes or expresses to people.

Interpretation means all the ways of presenting the cultural significance of a place.

1.6.2 Bridge specific definitions

Figure 1-12: Diagram showing Allan truss terminology from elevation

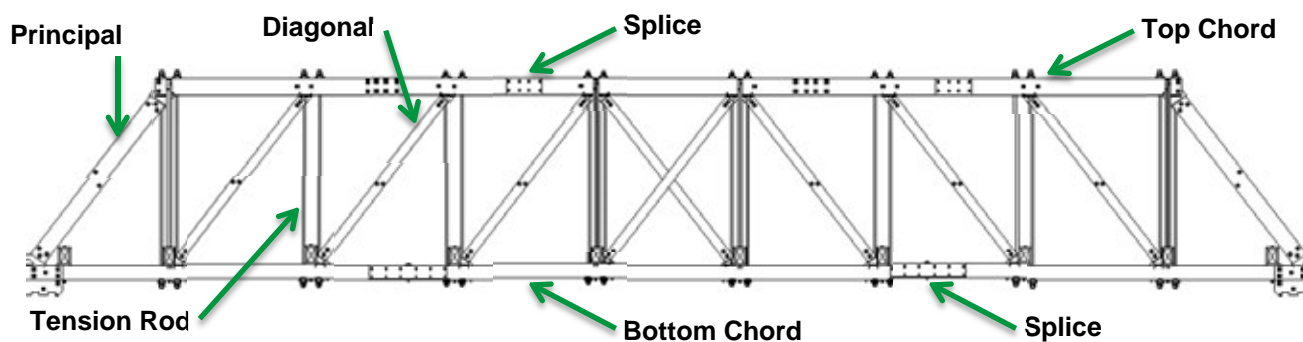

Source: author

Figure 1-13: Diagram showing Allan truss terminology from section

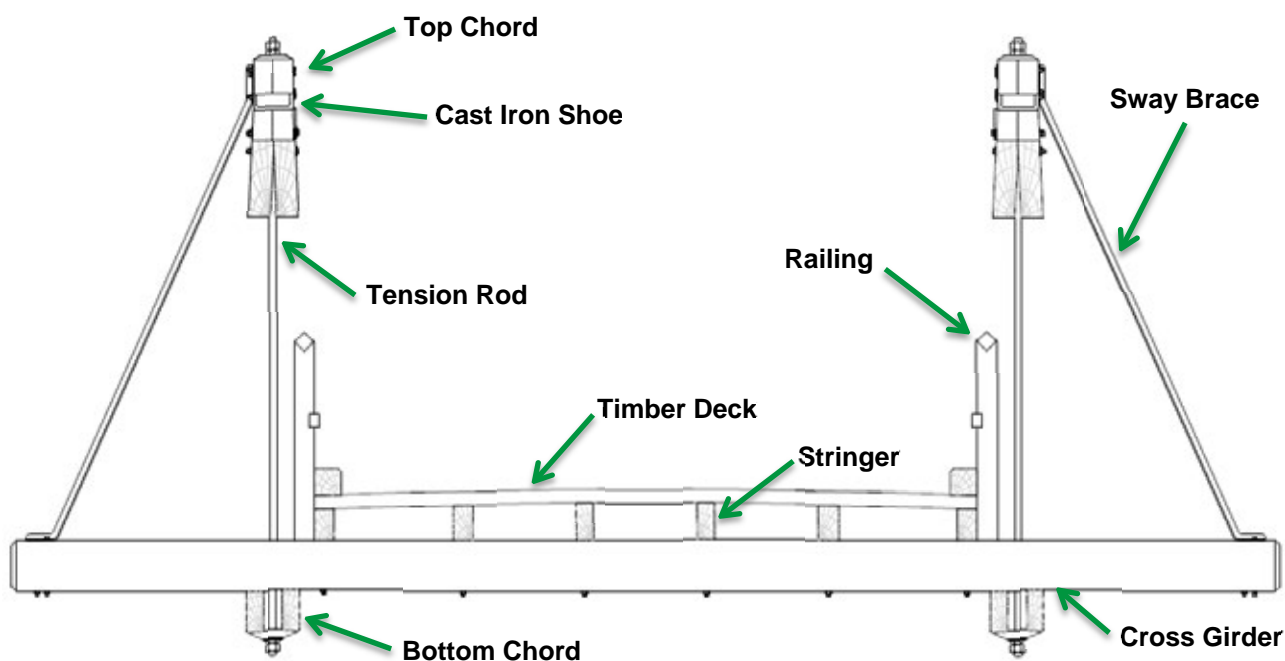

Source: author

Figure 1-14: Diagram showing timber abutment terminology from view

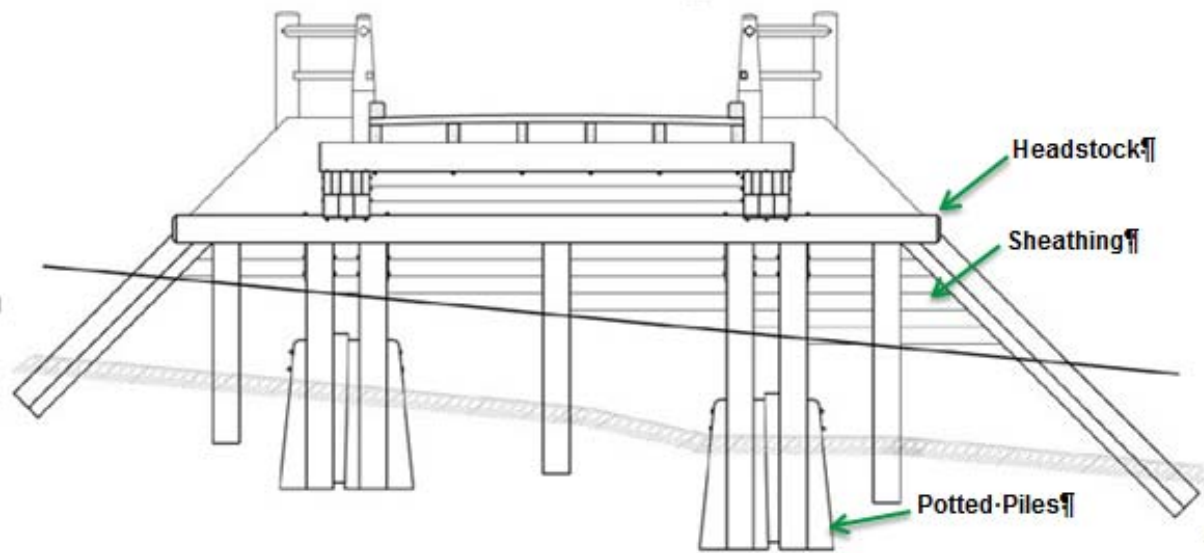

Source: Amie Nicholas

Figure 1-15: Diagram showing timber trestle pier terminology from view

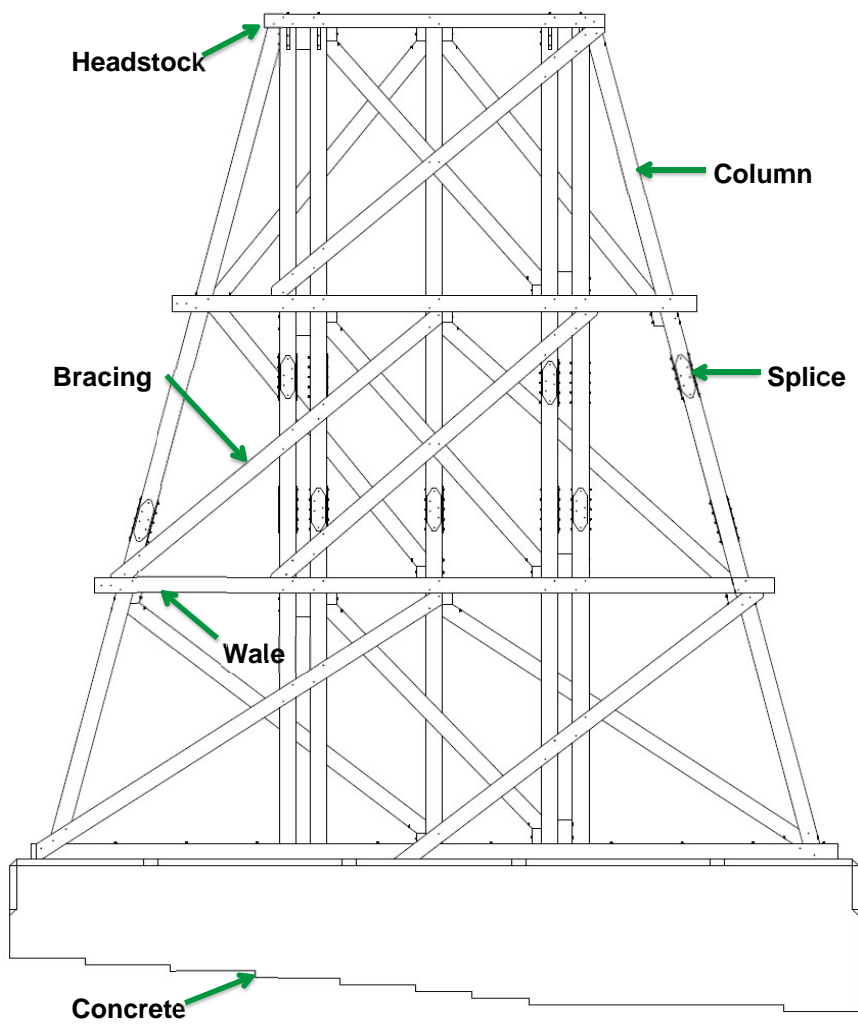

Source: Amie Nicholas

Abutment means the structure on which the ends of the outer spans are supported (Fig 1.2)

Bottom chord means the lower horizontal member of the truss (Fig 1.13)

Bracing means diagonal timber members in piers designed to provide lateral stiffness (Fig 1.15)

Cast iron shoe means the cast iron component which connects the ends of the truss principals and diagonals to the top and bottom chords (Fig 1.13)

Column means a vertical or inclined member which does not extend below ground level (Fig 1.15)

Cross girder means a transverse bending member spanning between the upstream truss and the downstream truss which supports stringers which in turn support the deck (Fig 1.13)

Deck means the components of the bridge which directly support vehicles or pedestrians (Fig 1.13)

Diagonal means a truss member placed at an angle, excluding principals (Fig 1.12)

Headstock means horizontal member at top of pier or abutment which supports corbels (Fig 1.14)

Panel means the area between the panel points (or main joints / intersections) in a truss (for example, the truss of Victoria Bridge shown in Figure 1.13 consists of nine panels)

Pier means a support for the adjacent ends of two bridge spans, and at Victoria Bridge consists of double timber trestle piers supported on concrete foundations (Fig 1.2)

Potted pile means a vertical or inclined member placed in a hole dug out of the rock because the soil is too shallow to drive a pile sufficiently deeply to support the bridge loads (Fig 1.14)

Principal means the primary end (diagonal) timber member in a truss (Fig 1.12)

Sheathing means the horizontal timber members used to restrain backfill at abutments (Fig 1.14)

Sill means a horizontal timber member on a concrete foundation which supports a pier

Splice means a discontinuity in the timber in either the top or bottom chord (or in an element of a pier) which is made to carry loads by use of a metal plate or other metal sections (Fig 1.15)

Stringer means a longitudinal member spanning between cross girders supporting a deck (Fig 1.13)

Sway brace means a member located outside the truss extending between the top chord and a cross girder to resist sway and vibration of the truss under vehicular loading (Fig 1.13)

Tension rod means a vertical metal bar connecting the top and bottom chords of a truss (Fig 1.13)

Top chord means the upper horizontal member of a truss (Fig 1.13)

Truss means a special class of structure in which members are connected at joints in a manner that permits rotation so that the individual members can only carry either tension or compression

Truss Corbel means a timber member used to increase the load bearing length of bottom chords over piers so that the timber can still take load after decay has begun (as it does) at the ends

Wale means horizontal timber members in piers designed to provide lateral stiffness (Fig 1.15)

2. Historical context

2.1 The unique hardwood timbers of New South Wales

When Europeans first explored Australia, they were less than impressed by the Australian timbers. Captain James Cook said in 1770 that the trees were so “hard and ponderous” that they were pretty much useless. Surgeon John White reported in 1790 that, “I do not know any one purpose for which it (Australian timber) will answer except for firewood; and for that it is excellent; but in other respects it is the worst wood that any country or climate ever produced.”⁹

Various newspaper articles of the late 1700s and very early 1800s describe the difficulties the convicts had in dealing with the Australian timbers due to their “monstrous bulk”, hardness and incredible weight.¹⁰ The trees in the immediate vicinity of the settlement at Sydney were too crooked, too hard to work, and too damaged by fire to be used as a structural material. Soon, however, timbers were discovered in New South Wales which would rival any in the world. Australian Red Cedar (*Toona ciliata*) was discovered in the Hawkesbury Flats and gangs of convicts were immediately sent to cut them down. Sixty logs from the Hawkesbury were exported to India as early as 1795, followed by loads to England, China, South Africa and New Zealand.¹¹

Figure 2-1: Forest of young Black-Butt Trees and Tallow-wood Logs for Transport in 1800s.¹²



Between 1855 and 1886, there were international exhibitions of timber in Paris, Melbourne, London, Sydney and New Zealand. The judges sawed the samples, planed them, nailed them and tested them for strength. Australian timbers met high praise.¹³ Experiments were made at the foundry of P.N. Russell & Co. in 1860 which showed how much tougher the ironbark is than Baltic or American timber. The conclusion made was that whatever span had been possible with timber in other countries could certainly be imitated, if not surpassed, in New South Wales.¹⁴

⁹ E.G. Trueman, *Timber Bridge Conservation in NSW*, Sydney: Hughes Trueman Ludlow, 1984, p 18.

¹⁰ “Sydney”, *Sydney Gazette and New South Wales Advertiser*, Sunday 7 August 1803, p 2.

¹¹ Eric Rolls, “A Land Changed Forever”, *In the Living Forest: An Exploration of Australia’s Forest Community*, edited by John Keeney, 2005, pp 16-19.

¹² J.H. Maiden, “Timbers of the Colony”, *New South Wales: the Mother Colony of the Australias*, edited by F. Hutchinson, Sydney: Charles Potter, Government Printer, Phillip Street, 1896

¹³ Eric Rolls, “A Land Changed Forever”, 2005, p 16.

¹⁴ *The Sydney Morning Herald*, Wednesday 16 May 1860, p 4.

In 1896, J. J. C. Bradfield, famous for the design of the Sydney Harbour Bridge, reported on the comparative strength of ironbark and iron, and found that, for the same weight, ironbark is more than three times stronger than iron in tension, and almost twice as strong as iron in compression.¹⁵ The Director of the Botanic Gardens in 1870 had the following comments to make:¹⁶

No country has been more favoured by nature with a greater variety and abundance of trees yielding strong, beautiful and durable timbers than the Colony of New South Wales...

Of late years the necessary requirements for building and fencing, and that employed for public works and for exportation, has considerably diminished the supply of several valuable kinds. The trees, however, cut down for these purposes have been small in number compared to those destroyed since the introduction of the system of choosing land by free selection. Persons taking up land under this system almost invariably choose the more richly-wooded places, fine timber-trees being characteristic of good soil. This remark more particularly applies to the forests of Illawarra, and those clothing the banks of nearly all the rivers north of it. It is comparatively but a few years since nearly the whole of the Illawarra basin was covered with magnificent forests, consisting of trees of vast variety, and of other plants of great beauty... The axe of the settler has no discrimination, - every tree disappears under its rude sway when the land is required for a homestead...

The soil of all brush-forest country is invariably rich, and whether on the coast or elsewhere, it is the first seized on for cultivation, and the destruction of the natural vegetation follows. From this and other similar causes nearly the whole of the brush-forests of Illawarra, the Hunter, the Manning, the Hastings, the Bellinger, and the Clarence, have been for the greater part cleared; those on the Richmond and the Tweed – formerly so extensive – are partially so, and all must be inevitably destroyed unless the Government take steps to prevent it... For commercial, industrial, climatic, and other reasons, the destruction of these forests is greatly to be deplored, but it is unavoidable...

Referring generally to hardwoods, but more particularly to those of the Eucalyptus genus, Sir William Macarthur, an excellent authority, makes some very pertinent remarks in the "Introduction to the southern woods" in the International Exhibition Catalogues... Of all these kinds the iron-bark is the most preferred, and is the most expensive... Under favourable circumstances it seems to be of an imperishable character, as some of it used for rafters in the earliest days of the Colony has been found as sound as on the day on which it was used... In the ground it is also most enduring; some posts of this, sent to the Paris Exhibition of 1855, and now deposited in the Kew Museum, near London, were perfectly uninjured above the ground-mark, and under it only partially affected. These posts were used for fencing, and were placed in the ground in the year 1815, where they remained, on the authority of Sir William Macarthur, for forty-six years. In the experiments made by Captain Fowkes on the timber sent from various parts of the world to the International Exhibition of 1862, a specimen of the wood of the Illawarra "ironbark" was, next to a Demerara wood, found to be the strongest of any sent to the Exhibition; and the result of similar experiments on the strength and elasticity of Colonial timbers, instituted by Colonel Ward, late Deputy-master of the Mint, at the request of the then Governor Sir William Denison, proved incontestably that the "ironbarks" were the strongest of any of the timbers subjected to the test, and these included nearly all the principal known kinds. The demand for this very excellent timber has always been so great, that in the more accessible places it has been almost cleared out. Vast quantities of it have been of late years used for railway-sleepers, and so much still continues to be required for this purpose that a sufficient supply cannot now be relied on... the average height to which Eucalypts attain in this Colony may be stated at from 100 to 120 feet, with a stem of from 3½ to 5 feet in diameter... In jungle forests they have been known to reach a height of 200 feet or more. In the

¹⁵ J.J.C. Bradfield, "Some Notes on Australian Timbers", read before the Syd. Uni. Eng. Society, 28-05-1896

¹⁶ Charles Moore, Esq., F.L.S., 'On the Woods of New South Wales', *The Industrial Progress of NSW, being a Report of the Intercolonial Exhibition of 1870, at Sydney; together with a variety of papers illustrative of the industrial resources of the Colony*, Sydney: Thomas Richards, Government Printer, 1871, pp 633-639.

open forests, in the Wingecarribee district, 150 feet is by no means an uncommon height for more than one species to attain.

Again in 1896, Botanist J.H. Maiden wrote that, "Ironbark stands alone as the embodiment of the combination of a number of qualities valued in timber, viz., hardness, strength, and durability... one of the main reasons why colonial timbers are not more used is because users are nervous through ignorance... I plead for a wider interest to be taken in our trees and our timbers, and that in place of the apathy which exists... it may be realised that study of them is not only full of interest, but, as a mental discipline alone, worthy of attention by the best intellects of the Colony."¹⁷

By 1904, the rapid disappearance of hardwoods was increasing due to the recognition of its value by the commercial world of Europe, South Africa, and the East. Around this time, the duty of inspecting exported timber fell to the Department of Public Works (PWD). It was thought that, whatever views may be held as to the advisableness of sending away large quantities of our best timbers, it was desirable that all such exports should be properly inspected and classed. In 1907 it was reported that excessive exports had greatly increased the price of timber and that unless there be some check given to the trade, national works were likely to be seriously handicapped.¹⁸ As Henry Lawson lamented, "But still the steamers sail out with our timber and wool and gold".¹⁹

Figure 2-2: Australian hardwood sleepers and girders being loaded at Darling Harbour for South Africa in 1903



Source: NSW Legislative Assembly: Report of the PWD for Year Ended 30 June, 1903

Percy Allan of the PWD rather discourteously described the difficulties in obtaining large long lengths of timber for timber truss bridges in 1895: "Again, some of the flitches are 53' 6" long and, having to be free of heart and sapwood, are difficult to obtain, and this oftentimes occasioned delay in the erection of the structures, the simple-minded sawmill proprietor supplying all the short and profitable sizes in the bridge, and then pleading inability to supply the more costly flitches."²⁰

It would seem that saw-millers had something of a reputation, as seen from the excerpt from Henry Kendall's poem 'Jim the Splitter' below. Thomas Henry Kendall (1839-1882) was born in Ulladulla,

¹⁷ J.H. Maiden, "Timbers of the Colony", New South Wales: the Mother Colony of the Australias, edited by F. Hutchinson, Sydney: Charles Potter, Government Printer, Phillip Street 1896, pp 168-180.

¹⁸ NSW Legislative Assembly: Reports of the Department of Public Works, 1903 p 64; 1901 p 73; 1899 p 12.

¹⁹ H. Lawson, *When I was King and Other Verses*, Syd.: Angus and Robertson, 1906, Australian Engineers.

²⁰ Percy Allan, "Timber Bridge Construction in New South Wales", read before the Engineering Section of the Royal Society of NSW on 18 Sept 1895, *Journal and proceedings of the Royal Society of NSW*, Vol 29, 1895, p VI. N.B. "heart" is also sometimes called "pith" and is the very middle bit of the tree which started as the very fast growing sapling, and so the wood is brittle, weak and subject to deterioration.

New South Wales, and was once regarded as Australia's finest poet, and is known for his distinctly Australian poetry. In addition to his poetry, Kendall worked for a time in the timber business in the Mid North Coast of NSW, and was, for the last 18 months of his life, appointed by Henry Parkes as inspector of forests, for which he was admirably fitted by his knowledge of native timbers.^{21, 22}

*When asked by the market for ironbark red,
It always occurs to the Wollombi head
To do a "mahogany" swindle.
In forests where never the ironbark grew,
When Jim is at work, it would flabbergast you
To see how the "ironbarks" dwindle...*²³

2.2 History of early timber bridges in New South Wales

The first bridge to be built in Australia was constructed in 1788 when a gang of convicts were employed in rolling timber together to form a bridge over the Tank Stream in Sydney. This bridge lasted more than 15 years until it was replaced in 1804 by a "more permanent" stone arch bridge, which collapsed within twelve months and had to be rebuilt.²⁴ The stone bridge was again largely rebuilt in 1811 at a cost of '660 gallons of spirits'.²⁵ The idea that timber bridges are "temporary" structures has been pervasive throughout their history, despite many of them outlasting so called "more permanent" structures made of "modern" materials such as steel and concrete.

This is clearly indicated in the report to the Legislative Assembly of New South Wales of the Department of Public Works in 1897, which states, "With regard to the repairs and maintenance of bridges, which now demand a large and yearly-increasing expenditure, the Assistant Engineer suggests, as settlement advances in the Colony, replacing timber structures, so far as practicable, by bridges of a more permanent character, and thus reducing the annual cost of repairs and maintenance. He points out that, in consequence of the improvement effected of late years to the surface of the roads, and the cutting down of grades, the bridges are now required to bear the strain of much heavier loads than they were estimated to sustain at the time they were built."²⁶

Percy Allan, the first Australian born engineer to be appointed Chief Bridge Engineer, challenged the popular idea that steel bridges were more economical in the long run than timber, arguing in 1924 that this idea was based on overseas experience with lesser quality timber. He said that, "In Australia, however, with timber bridges of modern design built of more durable hardwood, experience has shown that the popular idea has no solid foundation in fact."²⁷ As Mr Hickson, the Under Secretary for Public Works and Commissioner for Roads reported in 1897, "We must not lose sight of the fact that in New South Wales we possess the best timber in the world for bridge building... There are cases, no doubt, where it would be more economical in the long run to erect iron or, better still, stone bridges; but I feel satisfied that for many years to come it will be found more advantageous to use timber in the construction of a large proportion of our bridges".²⁸

²¹ T. T. Reed, 'Kendall, Thomas Henry (1839–1882)', *Australian Dictionary of Biography*, National Centre of Biography, Australian National University, [http://adb.anu.edu.au/biography/kendall-thomas-henry-](http://adb.anu.edu.au/biography/kendall-thomas-henry-/text6205)

²² /text6205, published first in hardcopy 1974 (accessed 20/02/2017)

²³ H. Kendall, *The Poems of Henry Kendall*, Sydney: Angus and Robertson, 1920.

²⁴ E.G. Trueman, *Timber Bridge Conservation in NSW*, Sydney: Hughes Trueman Ludlow, 1984.

²⁵ Department of Main Roads, NSW, *The Roadmakers*, A History of Main Roads in New South Wales, Sydney: Department of Main Roads NSW 1976.

²⁶ Report of the Department of Public Works to the Legislative Assembly for the year ended June 1896, p 8.

²⁷ P. Allan, "Highway Bridge Construction", *Industrial Australian and Mining Standard*, 14 Aug 1924, p 243

²⁸ Report of the Department of Public Works to the Legislative Assembly for the year ended June 1896, p 8.

The early days of bridge building in Australia were largely experimental and not always successful. The first timber arch bridge was built in Maitland in 1852.²⁹ Timber arches were popular at first for both road and rail bridges but fabrication was difficult, and they were subject to deterioration and distortion, and so this type of bridge did not last very long, and none remain today. The main problem was the separation of the laminates, due to the large amount of shrinkage of the Australian hardwoods, and the consequent penetration of water into the joints. Once fungi or termites attacked the timber it was impossible to renew the laminates or portions of the arch. These bridges were costly to build, and as their short lives proved, they were not cost-effective.³⁰

Despite the early difficulties with timber as a structural material in NSW, engineers continued to experiment, and the first timber truss bridge in NSW was built in Carcoar between Bathurst and Cowra in 1855 (opened 1856).³¹ Although good work was done by the early colonial road engineers, the real engineering history of NSW road bridges dates from the formation of the Public Works Department in 1858 shortly after the inauguration of responsible Government in the Colony.³²

Figure 2-3: The laminated timber arch bridge over South Creek at Windsor in 1872



Source: . DMR, *The Roadmakers, Sydney: Department of Main Roads, NSW, 1976, p 54*

²⁹ Department of Main Roads NSW, *Timber Truss Bridge Maintenance Handbook*, February 1987, p 7.

³⁰ Department of Main Roads NSW, *Timber Truss Bridge Maintenance Handbook*, February 1987, pp 7-8.

³¹ *The Sydney Morning Herald*, Monday 31 December 1855, p 4.

³² .

Figure 2-4: First Timber Truss Bridge in NSW over the Belubula River, Carcoar, 1856



Source: American & Australasian Photographic Company, 'Brick-making on the banks of the river at Carcoar' c.1870-75, State Library of NSW

2.3 History of timber truss bridge design in New South Wales

Between 1856 and 1936, over 400 timber truss road bridges were built in New South Wales. Five exceptional engineers working for the NSW Department of Public Works applied their sound engineering principles to design these elegant and durable timber truss bridges, some of which continue to carry vehicles today that are larger and heavier and faster than the original designers could possibly have imagined. The vast majority of these bridges can be divided into five types:

- 1) Old PWD trusses designed by William Christopher Bennett, 1824-1889, Fig 2.5.1
- 2) McDonald trusses designed by John Alexander McDonald, 1856-1930, Fig 2.5.2
- 3) Allan trusses designed by Percy Allan, 1861-1930, Fig 2.5.3
- 4) De Burgh trusses designed by Ernest Macartney de Burgh, 1863-1929, Fig 2.5.4
- 5) Dare trusses designed by Henry Harvey Dare, 1867-1949, Fig 2.5.5

The earlier trusses made use of the vast resource of large, long, strong and durable NSW hardwoods. As the unique NSW hardwoods became known around the world, so much of it was exported that these earlier types of timber truss bridges could no longer be built. The later trusses limited the sizes of the timbers used to smaller shorter sections which were still readily available.

Figure 2-5: The timber truss bridge engineers, Bennett, McDonald, Allan, de Burgh and Dare³³

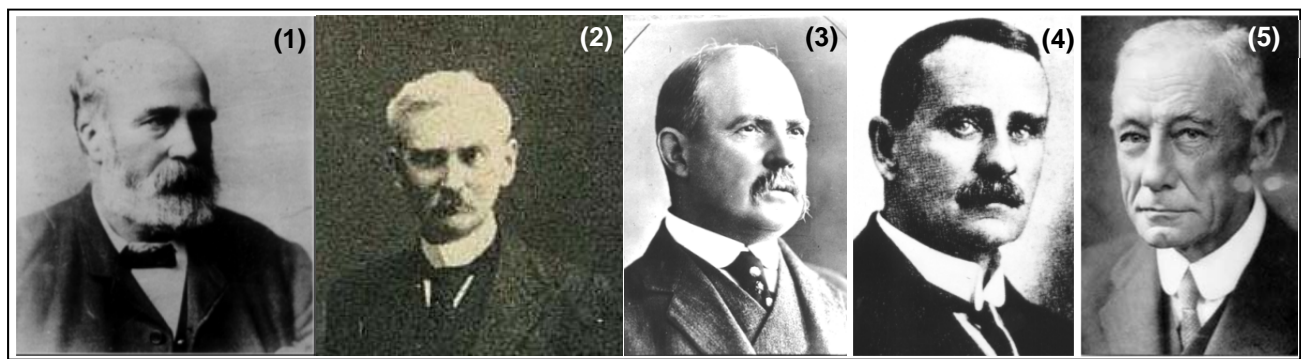

2.3.1 Old PWD trusses

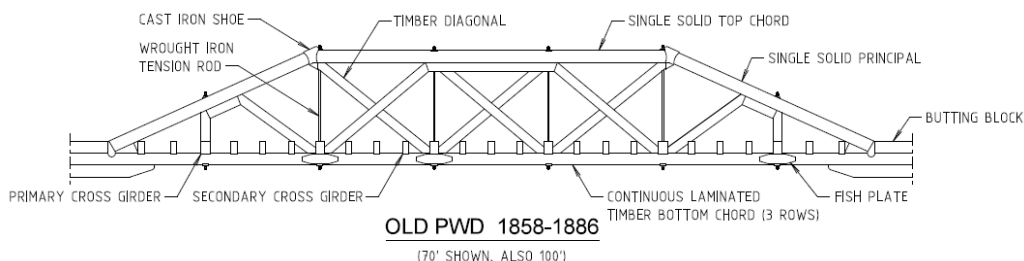

Examples of innovative and practical engineering in a time when large long timbers were readily available and vast numbers of bridges were being built, but budgets were tight and skilled workmen were few. The Old PWD trusses were not designed as permanent structures because the required routes were very likely to be diverted by circumstances impossible to anticipate.

2.3.2 McDonald trusses

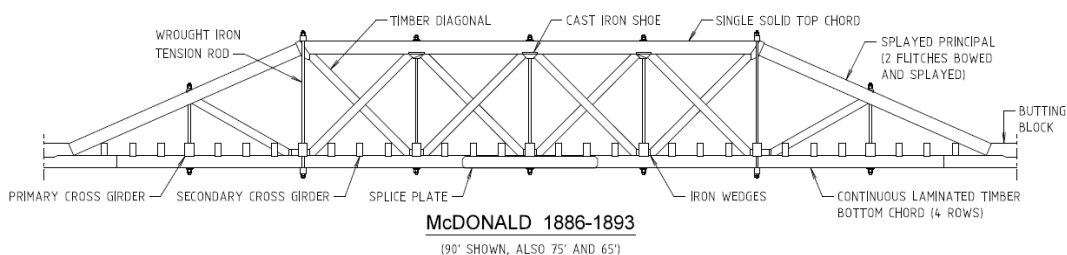

The historical context which drove the design of the McDonald truss is similar as large, long, quality hardwoods were still plentiful and permanent bridges were not considered economical. The changes in design stem from the growing knowledge of timber as a structural material due to extensive testing at the University of Sydney in 1886, and also the increasing heavy vehicle loads.

³³ sources 1 & 4: MBK, Study of Relative Heritage Significance of All Timber Truss Road Bridges in NSW, 1998, pp 23, 37; 2: "Pix from the past", Gisborne Photo News, No. 239, 22 May 1974, p 56; 3: "Mr Percy Allan, Noted Engineer's Death", The Sydney Morning Herald, Thursday 8 May 1930, p 12; 5: Engineering Heritage, Sydney <http://www.engheritage-sydney.org.au/PDFs/Darlington.pm.pdf>.

2.3.3 Allan trusses

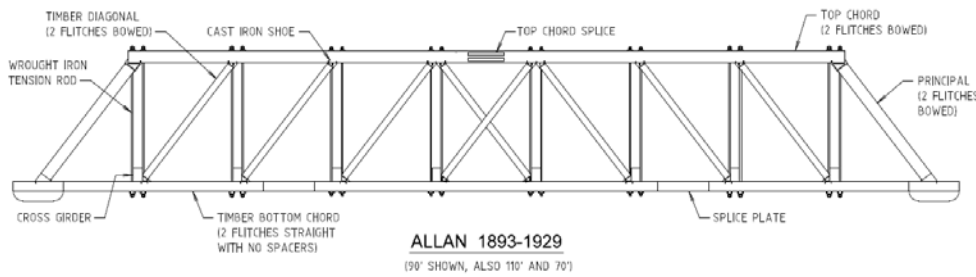

The historical context which drove the design of the Allan truss was the increasing difficulty in obtaining large long timbers. Allan introduced two important innovations in his timber truss design. The first was the detailing of timbers to enable the replacement of deteriorated timber, giving his timber bridges the same life expectancy as metal bridges. The second innovation was his splice connection in the bottom chord which was much stronger than previous bottom chord connections.

2.3.4 De Burgh trusses

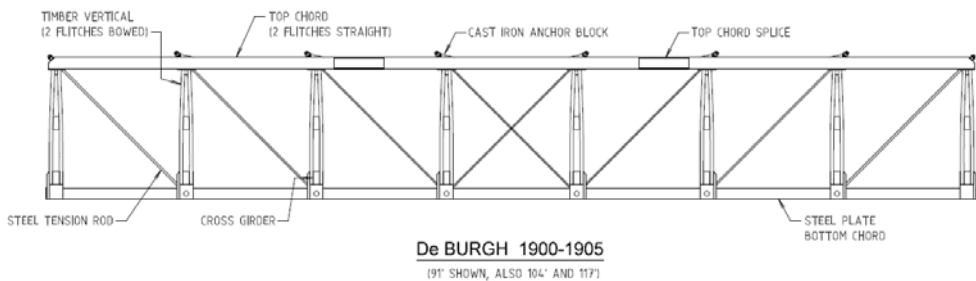

The historical context which drove the design of the de Burgh truss bridges was the fact that materials other than timber had become increasingly available and economical. The de Burgh truss includes the greatest variety of materials found in any of the NSW timber truss bridges, and de Burgh used each material to its best advantage. The result was a stiffer and stronger truss, so that de Burgh achieved the longest span (50m) timber truss bridge in NSW.

2.3.5 Dare trusses

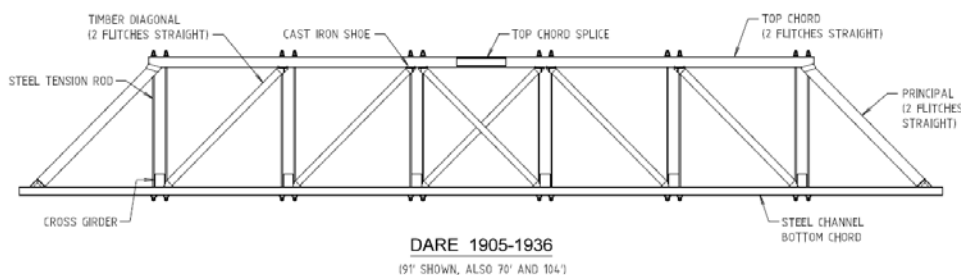

The historical context which drove the design of the Dare truss was a desire to combine the best aspects from the de Burgh and Allan trusses, while avoiding the primary problems with each. The Dare truss has the simplest geometry and allows the easiest replacement of individual timbers.

2.4 History of the Allan truss

2.4.1 Percy Allan (1861-1930)

Figure 2-6: Percy Allan



Percy Allan was born on 12 July 1861 in Sydney and was Educated at Calder House in Sydney.³⁴ He joined the Roads Branch, Department of Public Works, as a cadet in 1878. With patronage still a leading factor in public service preferment, Allan's new post owed something to his father's position as Principal Under-Secretary of the

Colonial Secretary's department. Maxwell Rennie Allan's career closed with his death only months later in 1879. Percy Allan's grandfather, David Allan, had arrived in Australia in 1808 and was Deputy Commissary-General from 1818 to 1823.³⁵

Percy Allan became Assistant Draftsman in 1882 and Chief Draftsman in 1889. His training by pupillage continued under senior engineers within the department in accordance with the conditions prescribed by the Institution of Civil Engineers, London, although some of his contemporaries were pioneers in academic schools of engineering.³⁶ In 1893, upon the retrenchment of McDonald, Allan introduced significant changes to both timber beam and timber truss bridge design, including the development of what is now known as the Allan truss.³⁷

³⁴ Ashworth P. Burke, *History of the Colonial Gentry*, London: Harrison and Sons, 1895 p xxii.

³⁵ 'Mr. Percy Allan. Noted Engineer's Death', *The Sydney Morning Herald*, Thursday 8 May 1930, p 12.

³⁶ Arthur Corbett, 'Allan, Percy (1861–1930)', *Australian Dictionary of Biography*, National Centre of Biography, Australian National University, <http://adb.anu.edu.au/biography/allan-percy-4996/text8303>, published first in hardcopy 1979, accessed online 23 June 2017.

³⁷ Annual Report of the Department of Public Works to the Legislative Assembly 1894, p 123.

By this time, he had worked with Bennett for over ten years and with McDonald for almost 15 years. He had worked briefly with Professor Warren, and had had the benefit of de Burgh's assistance for eight years and Dare's for four years. A timeline showing the periods of construction of the different truss types and the periods of employment of the different design engineers is provided in Figure 2.7. Allan was able to make significant progress in the design of timber truss bridges because he had access to information regarding the structural properties of Australian hardwoods and 35 years of historical data on various timber designs. He also had access to a team of exceptional young engineers to assist in design development.

Figure 2-7: Years employed by PWD and years of construction of truss types

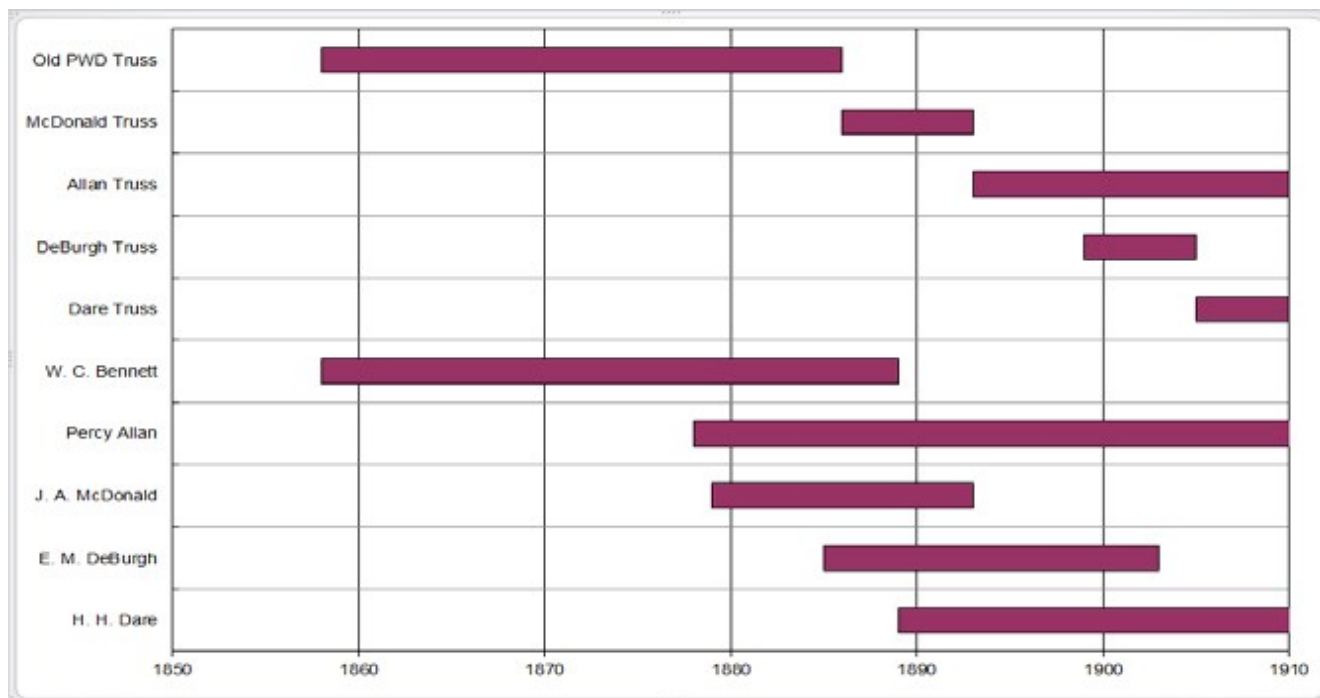

Source: Amie Nicholas

Appointed Assistant Engineer for Bridges in 1895, he was promoted a year later to engineer-in-charge of bridge design. In 1900 Allan assumed increased responsibility for rivers, artesian bores, water-supply and drainage. His work included supervising the construction of Sydney's sewerage system with ocean outfalls. In Newcastle from 1908 until 1912 as District then Chief Engineer, among other things, he designed and built additional coal-loading wharves and cranes. From 1917 until he retired in 1927 he was Chief Engineer, National and Local Government Works.³⁸

Percy Allan was the first president and a life member of the Northern Engineering Institute and of its successor, the Newcastle division of the Institution of Engineers, Australia. He was also a member of the American Society of Civil Engineers. He had a distinguished career, and left many monuments, having designed nearly six hundred bridges. Dr J.J.C. Bradfield (designer of the Sydney Harbour Bridge) said that whatever success he had attained he owed largely to the assistance he had received from Allan in his youth.³⁹ Allan was awarded a Telford Premium in 1921 by the Institution of Civil Engineers (London), for a paper submitted on the port improvements at Newcastle. The Telford Premiums were monetary awards for papers considered worthy, and, according to the newspapers of the day, were highly regarded.⁴⁰

³⁸ Arthur Corbett, 'Allan, Percy (1861–1930)', *Australian Dictionary of Biography*.

³⁹ "Mr Percy Allan, Colleagues' Farewell", *Sydney Morning Herald*, Friday 5 March 1926, p 12.

⁴⁰ "Sydney Engineers Honoured, The Telford Premiums", *SMH*, Wednesday 4 May 1921, p 10.

In addition to designing timber truss bridges, Percy Allan designed the very innovative swing spans for the Pyrmont Bridge and the old Glebe Island Bridge. The fact that Pyrmont Bridge was Australian designed and Australian built was a focal point for national pride at the time of federation.⁴¹ Percy Allan also designed a number of lift spans some of which were even noticed overseas, such as the ones at Swan Hill, Tooleybuc and Dunmore, and a number of steel truss bridges, including Tom Uglys Bridge over the Georges River in southern Sydney.⁴²

2.4.2 Evolution of the Allan truss design

The Allan truss was the third in a five-stage design evolution of NSW timber truss bridges. Allan's design was driven by financial and resource constraints. Money was scarce after the bank crashes in London in 1890 and in Australia in 1892-3.⁴³ Labourers and supervisors were being laid off and engineers (such as McDonald) retrenched or forced into early retirement. Large section timbers were increasingly scarce and therefore expensive and sometimes simply unobtainable. Earlier designs were not intended as permanent structures since the road alignments were still being developed, and so they were expensive to maintain, and often had to be completely replaced.⁴⁴

The focus for Allan in his design was the use of small section timber designed for maintainability. Allan introduced two important innovations in his timber truss bridge design. The first and most critical innovation was the detailing of timbers to enable the relatively easy replacement. This meant that the timber bridge would be more economical than an equivalent "permanent" metal bridge, not only for initial construction, but also over the whole life of the bridge (Fig 2.8).⁴⁵

The design philosophy of the architect, landscape gardener and poet, Thomas Pope applied⁴⁶

<i>When Time, with hungry teeth, has wrought decay, Then what will sceptics be dispos'd to say? Why, "down the Bridge must fall, without repair, And all the author's pleadings will be air." Not so, he's better arm'd than you'd expect,</i>	<i>For nought can bring to ruin but neglect; A means provided, which can never fail, To keep up strength whate'er the B ridge may ail; Each log of wood, where'er its station be, Is safely shifted for a sounder tree...</i>
--	---

Allan explained in less poetical terms how he saw it working for his timber truss bridge design:

One of the features of the new type of truss is that any member can be renewed without staging from below, a matter of importance when deep gorges or fast running streams have to be crossed. Briefly stated, the top and bottom chords being in two pieces, the suspension rods (by which Allan means tension rods) are removed and re-arranged so as to throw the whole weight on one flitch; there being no strain on the remaining flitch, any member of the top and bottom chord can be replaced with sound timber; and by slacking the suspension rods and inserting temporary struts, any of the braces can be renewed, whilst the renewal of the cross girders is obviously a simple matter.⁴⁷

⁴¹ Engineers Australia, Proposal to landmark the Pyrmont Bridge, National Engineering Landmark, 1991, p 5.

⁴² H.G. Tyrrell, *Evolution of Vertical Lift Bridges*, Toronto: University of Toronto Engineering Soc., 1912 p 12.

⁴³ Richard Raxworthy, *The Unreasonable Man*, Sydney: Hale and Iremonger, 1989, p 24.

⁴⁴ Percy Allan, "Timber Bridge Construction in New South Wales", 1895, pp I-VI.

⁴⁵ Percy Allan, "Timber Bridge Construction in New South Wales", 1895, p XIV.

⁴⁶ Thomas Pope, *A Treatise on Bridge Architecture*, New York: Alexander Niven, 1811, p 284.

⁴⁷ Percy Allan, "Timber Bridge Construction in New South Wales", 1895, p VIII.

Figure 2-8: Comparison of Annual Charge for Iron vs Timber Bridges

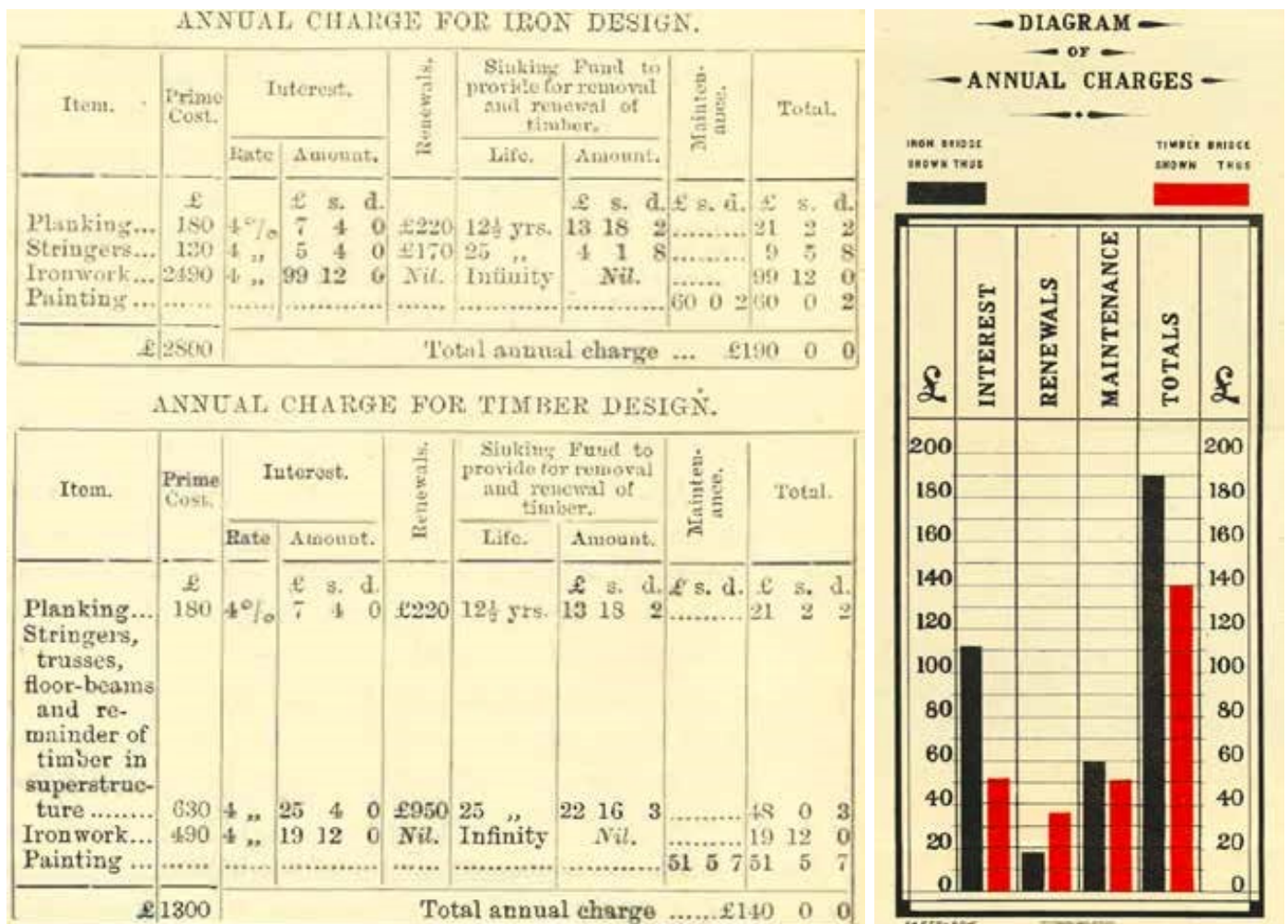

Source: Percy Allan, 1895

While it is true that replacement of timbers in the Allan truss is considerably simpler than replacement of timbers in the Old PWD or McDonald trusses (which Allan described as something like a Chinese puzzle (“Percy Allan, Timber Bridge Construction in New South Wales”, 1895, p XVI.”), it was not achieved quite in the way which Allan had anticipated. As early as 1904, Dare reported that, “in almost every case the timber lower-chord has been the first member of the truss to fail, and the flitches, being in tension, are very difficult to replace”.⁴⁸ The flitches of the top chords also are more difficult to replace than implied by Allan’s enthusiastic statements. Due to the fact that the flitches of the top chords are bowed to prevent warping and twisting, a single flitch is not really able to keep its shape and take the load without the other. Luckily for Allan, other engineers invented methods of temporary support to replace the timbers.

Allan’s second innovation was his splice connection in the bottom chord which was much stronger than previous bottom chord connections and did not require such long lengths of timber. Allan’s splice connection was subsequently used by the railways and as far away as the United States.⁴⁹

⁴⁸ Henry Harvey Dare, “Recent Road-Bridge Practice in NSW”, p 388.

⁴⁹ Percy Allan, “Timber Bridge Construction in New South Wales”, 1895, p VII.

Figure 2-9: Rail bridge near Walgett NSW with Allan's bottom chord splice



Source: Amie Nicholas 2013

The bottom chord splices being so critical, Allan tested the full-size joint in a machine specially designed for the purpose (Fig 2.10). The machine consisted of a heavy ironbark frame and large hydraulic jack. In the three tests conducted, failure occurred by the shearing of the bolts and of the timber between the notches, the recorded results showing an ultimate strength of 151, 160 and 182 tons (153, 162, 185 tonnes) respectively, the size of the timber flitch was 13" x 6" (330 x 150 mm) and the steel plates 12³/₄" x 1/2" (324 x 12 mm).⁵⁰ Warren noted that for ironbark timber, the shearing resistance along the fibre is generally about 2,000 lbs. per square inch (14 MPa).⁵¹

⁵⁰ P. Allan, "Highway Bridge Construction II", *Industrial Australian and Mining Standard*, 21-08-1924, p 285.

⁵¹ "Correspondence on Swing Bridges", Minutes of Proceedings of the Institution of Civil Engineers, 16 April 1907, p 88.

Figure 2-10: Allan's Photo of chord testing machine at the Biloela Dockyard⁵²

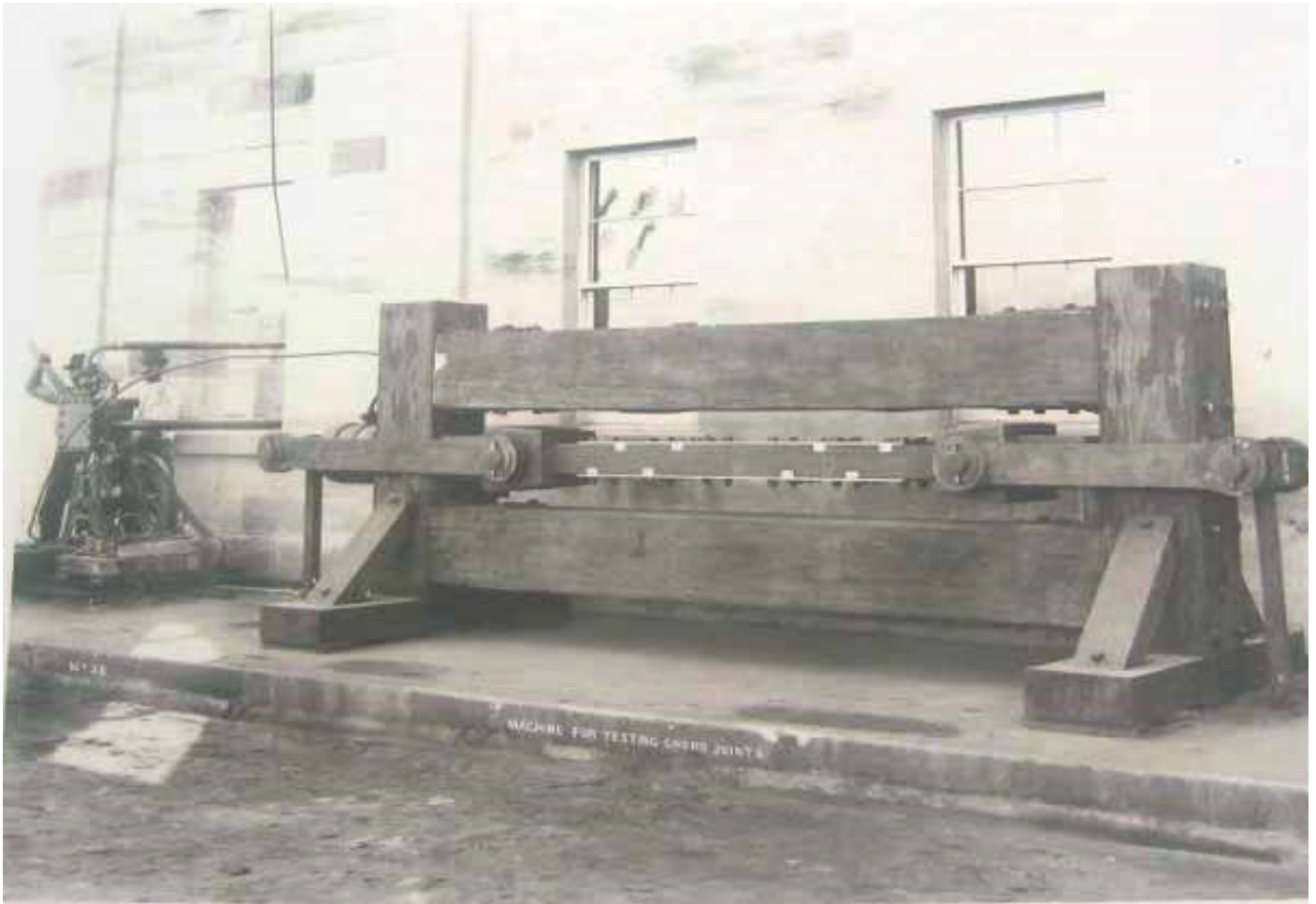

Source: Cockatoo Island

Figure 2.11 on the following page shows sketches prepared by Percy Allan to describe the differences between the bottom chord details in the Old PWD, McDonald and Allan trusses. Within this figure:

- Figure 1 shows the details for the Old PWD truss, which consists of a laminated timber bottom chord with three rows of laminates and a small metal fish plate at each joint location, designed not to carry any loading, but to provide a template to ensure correct bolting.
- Figure 2 shows the details for the McDonald truss, which consists of a laminated timber bottom chord with four rows of laminates and two large central metal splice plates, designed to share the load because this truss type was designed for heavier vehicles.
- Figure 3 shows the details for the Allan truss, which consists of a double timber bottom chord with a gap between each element and a direct tension connection made up of four wrought iron plates with metal shear keys riveted to them and then these plates bolted to the timber.

⁵² Otto Cserhalmi, Pyrmont Bridge Conservation Management Plan, 2006, p 59.

Figure 2-11: Comparison of bottom chord connection details

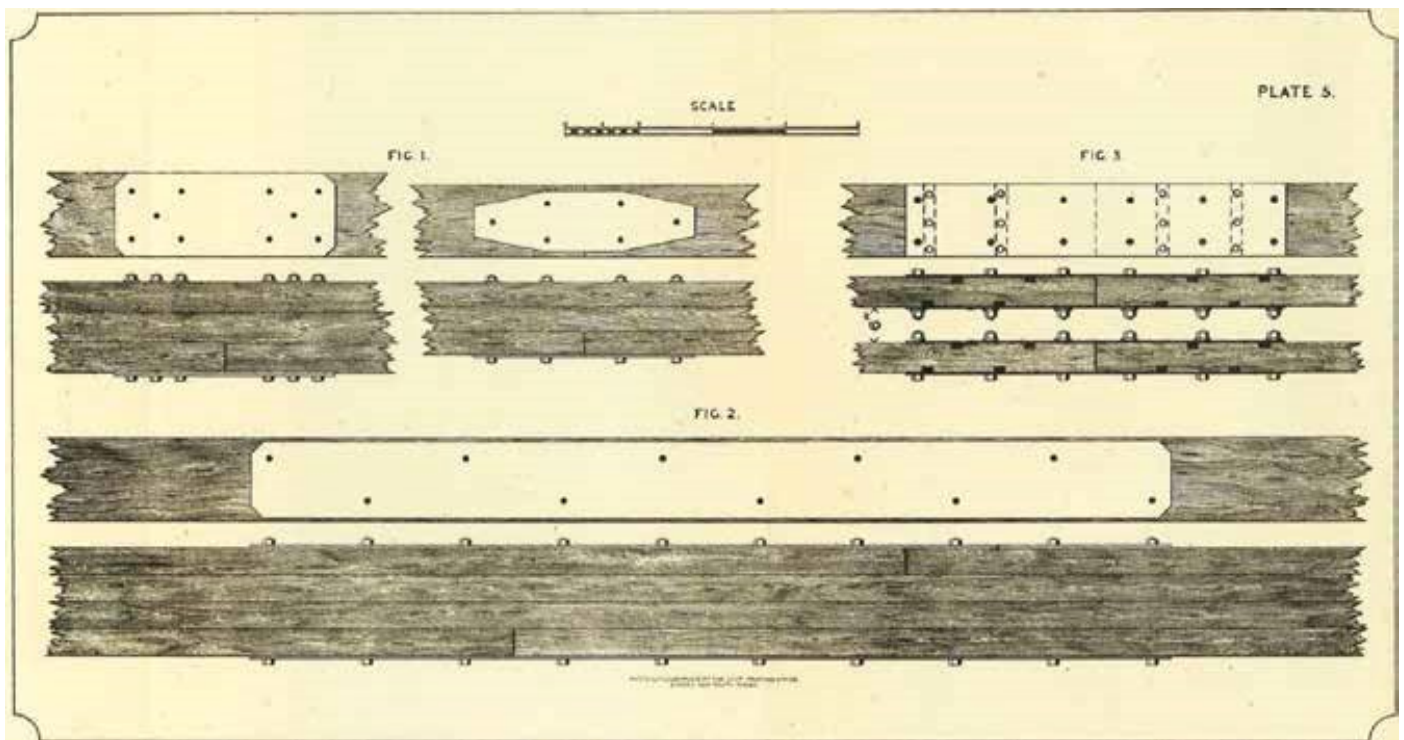

Source: Percy Allan, 1895

Allan described his bottom chord innovation as follows:

The bending stress in the bottom chord of the new truss having been eliminated by the omission of intermediate floor beams (ie. cross girders), only a direct stress has to be provided for, resulting in a considerable reduction in the sectional area of the bottom chord, which consists of two flitches 12" by 5" (304 x 127 mm) placed 6 inches (152 mm) apart, thus being always accessible to the brush, and permitting of the renewal of these important members; again the longest flitch is only 36 feet (10.97 m), a length easily procurable.

Perhaps the most important connection in a timber truss is the bottom chord joint... As the two flitches in the bottom chord are independent of one another, the whole stress in each flitch has to be taken by the two 12" by 5/16" (304 x 8 mm) wrought-iron plates placed on either side of the beam; on each of these plates four wrought-iron strips 12" deep by 1 3/4" wide by 1" deep (304 x 45 x 25 mm) are riveted; these strips are let tightly into the timber and are designed to take up the whole of the stress, and, as the stress in each flitch is 31.18 tons and there are four strips giving a total bearing area of 48 square inches, the crushing strain is only 0.65 tons per square inch, thus giving a factor of safety of 7 1/4 against crushing, whilst for shearing along the grain a minimum factor of 15 is provided.

Following American practice, the bolts passing through cover plates are not in any way relied upon, being simply provided to keep the plates up to their work, however as the bolts had to be provided the author determined to obtain the benefit of them, and arranged for the bolts to be turned and passed through drilled holes in the plates⁵³

It is undeniable that Allan's bottom chord tension splice was a very clever innovation, achieving a stronger and more economical timber bottom chord than the previous timber truss designs. However, this did not come without a cost. The earlier laminated timber bottom chords did not fail suddenly without warning, but tended to stretch and sag over time until they were replaced. Allan's new bottom chord, however, would

⁵³ Percy Allan, "Timber Bridge Construction in New South Wales", 1895, pp VI-VII.

tend to simply snap suddenly under a heavy load, and sometimes this would cause the entire truss to collapse. Though Allan sought to improve durability over the previous designs, his bottom chord splices were still subject to accelerated deterioration.

While Bennett sought to avoid the limelight, and McDonald certainly seemed not to seek popularity, Allan was vocal in coming forward and announcing his achievements to the world.

The PWD Report to the NSW Legislative Assembly for the Year 1893-4 details Allan's innovations:

*The type design for truss bridges in use since 1884 [sic, 1886] has been superseded by a truss of more modern design, the principal features of which are: the use of marketable lengths of timber, the adoption of open chords and braces always accessible to the brush, and the ease with which any defective timber can be replaced. In each of the new 90-foot spans there is a saving of 450 cubic feet of timber, while the trusses are capable of carrying 10 feet more roadway [sic, two 5' footways] than in the old type of truss, thus affording greater travelling facilities at reduced cost. Not only is there a saving in materials in the new type of truss, but a considerable saving is effected owing to the shorter lengths of timber employed and the greater ease in framing together. Altogether the saving effected by the adoption of the new type of truss bridge is on the average about 20 per cent*⁵⁴

Allan here compares his design loads with previous truss types:

- There is no remaining record of Bennett's design load for the Old PWD, other than the fact that it was less than the design load for later timber truss bridge designs.
- The 90' McDonald truss was designed for a 16 tonne traction engine plus a distributed live load of approximately 50 tonne (this distributed live load was probably for cattle).
- The 90' Allan truss was designed for a 16 tonne traction engine plus a distributed live load of approximately 75 tonne (again primarily for cattle, designed over a wider deck area).

The reason for this additional design load in the Allan truss is quite interesting. Allan designed his truss to accommodate a central roadway and two footways on the outside of the truss (one on each side) although this configuration was never actually used in an Allan truss.

⁵⁴ Annual Report of the Department of Public Works to the Legislative Assembly of NSW, 1894, p 72.

Figure 2-12: Sketch of Allan's proposed 90' Allan truss

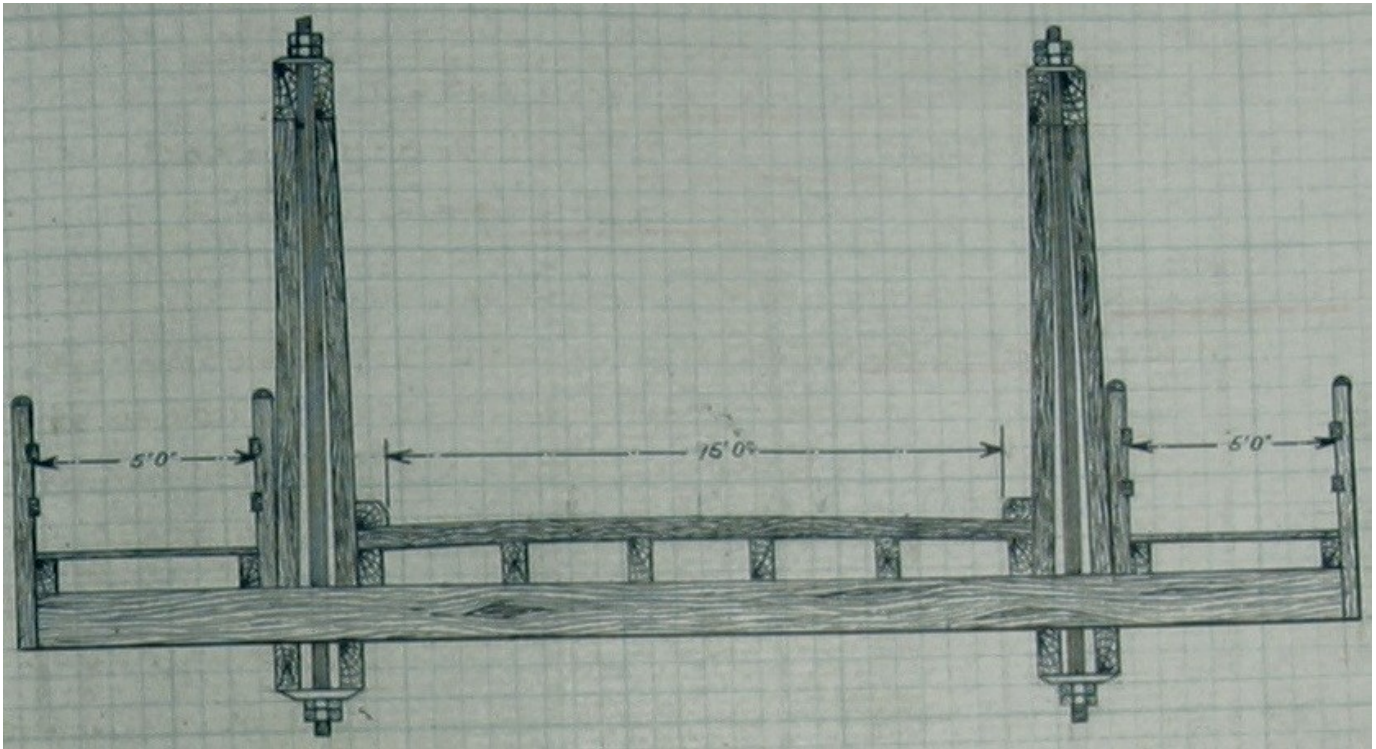

Source: Allan's calculation book, p 240

In order to accommodate the external footways, Allan attempted to do away with the sway braces, which inevitably make the external footway difficult, and replace these with what he called "wind stays". Since the "wind stays" could not provide any lateral support to the top chord, Allan designed his top chord in such a way that he thought that no lateral support would be required:

The side braces (by which Allan means the sway braces) adopted in previous trusses being a source of inconvenience when footways had to be provided, the author decided to design this chord as a column with a varying load, unsupported in a lateral direction; none of the text books however, consulted by the author treated of such a case... The author therefore has dealt with the case in what he submits, is a practical way of looking at the question...⁵⁵

Some of the very earliest Allan truss designs showed bridges with only short cross girders and no sway braces, and a handful were actually constructed to that design, but generally they had to be modified shortly after construction in order to provide the necessary lateral stability to the truss.

⁵⁵ Percy Allan, "Timber Bridge Construction in New South Wales", 1895, pp IV-V.

Figure 2-13: Comparison of early and later Allan truss bridges

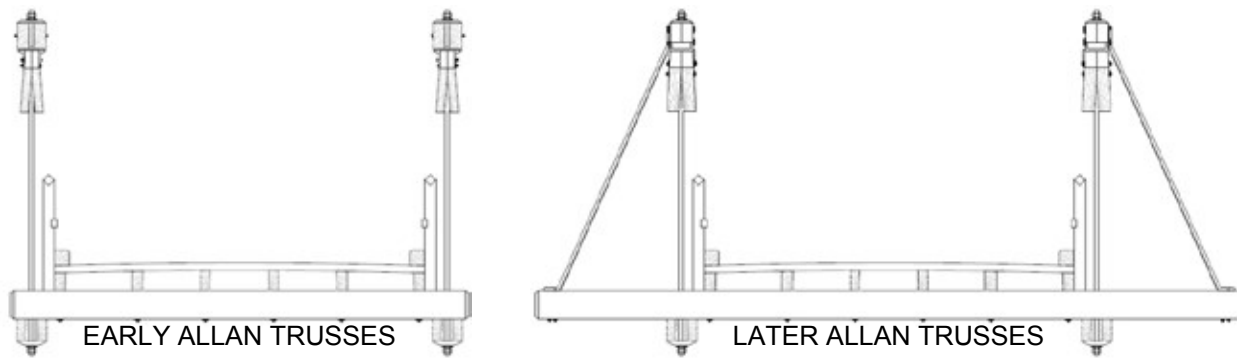

Source: Amie Nicholas

The only bridge remaining today which was originally constructed without sway bracing is Tharwa Bridge in the ACT. Tharwa Bridge over the Murrumbidgee River was opened in March 1895, and was constructed with Percy Allan's "wind stays" rather than the later sway braces. The photograph in Figure 2.14 was taken in 1964 and shows the original wind stays which were a unique and short-lived feature of Allan's earliest trusses. In 1965 a 25 tonne load limit was placed on the bridge because of signs of deterioration, and it was probably around this time that the "wind stays" were removed and rather chunky metal sway braces were added to Tharwa Bridge. These remained until the bridge was rehabilitated in 2008-11 at which time a larger number of more slender sway braces were installed on each of the trusses, similar to what became the standard design.

Most of the early Allan trusses had sway braces added more quickly. Some were designed by de Burgh during construction (for example, the bridge over the Edward River at Deniliquin) which avoided difficulties of excessively short cross girders, while others had to be designed by Allan to fit the completed bridge. For example, Stoney Creek bridge on the Bega to Bodalla road was constructed in 1894 and Allan provided a strengthening design only three years later in 1897 which included extensions of timber cross girders bolted to the sides of the originals and installation of metal sway braces which had to be bolted to the sides of the cross girder extensions rather than the tops due to eccentricity. The most beautiful example of a modification to make up for lack of lateral stability for the top chord is the fourth Allan truss bridge constructed, which was the Dry River Bridge at Quaama, opened in 1894. Figure 2.15 shows the overhead metal bracing which had been tastefully added to keep the trusses from excessive lateral movements. This overhead bracing remained on the bridge until it was replaced with a concrete bridge in 1972.

Figure 2-14: Tharwa Bridge with original wind stays (approximately 1964)

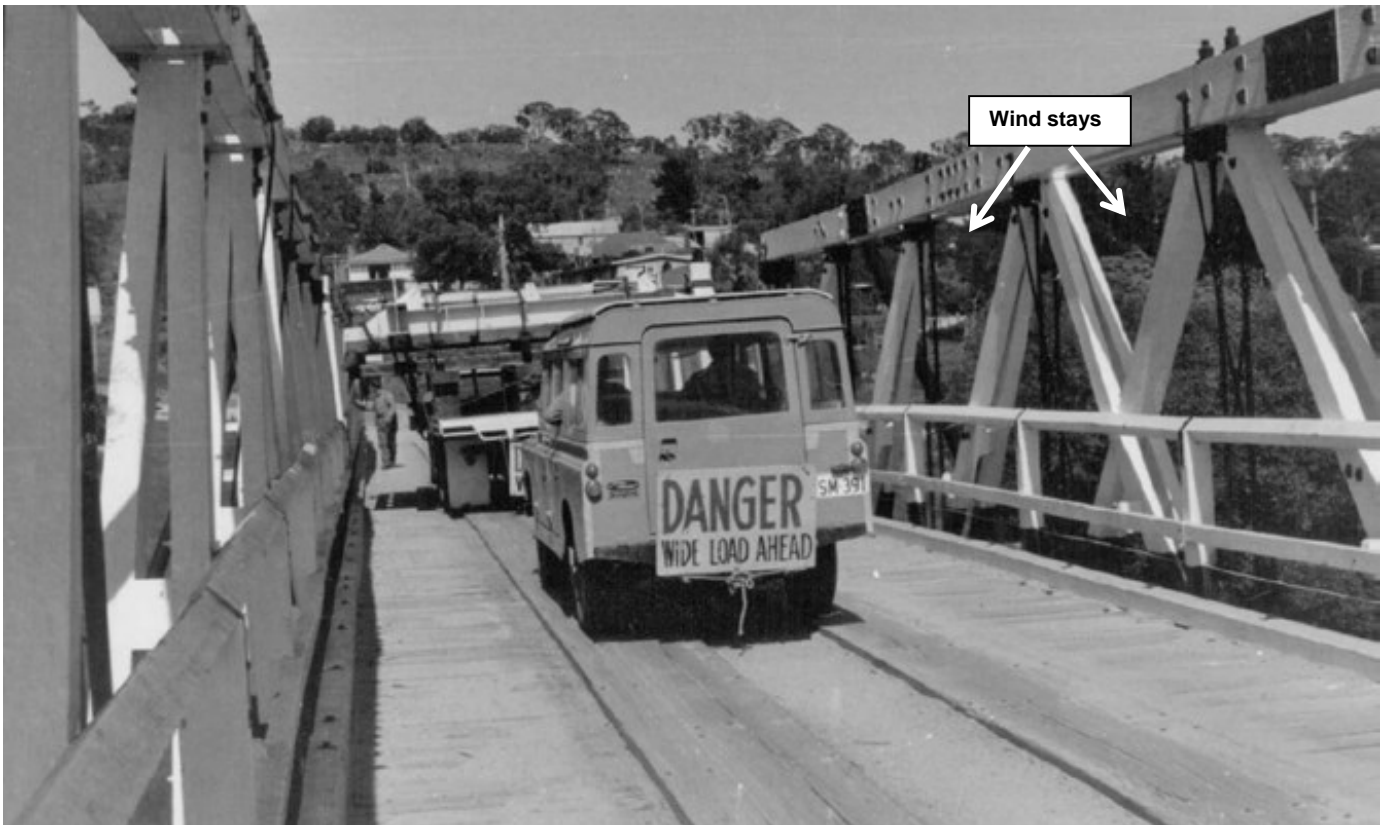

Source: <https://www.honeysucklecreek.net>

Figure 2-15: Early Allan truss with overhead bracing added, undated



Source: NMA Collection

While Allan used two different sizes of tension rods similar to the McDonald and Old PWD truss before him, Allan used the same size diagonals throughout (see Figure 2.16). This means that the diagonals towards the ends of the span are considerably more stressed than the diagonals towards the centre of the span. For this reason, many Allan trusses have had to have the first and second diagonals strengthened.

Figure 2-16: Details of principals and diagonals, Allan's 1896 design

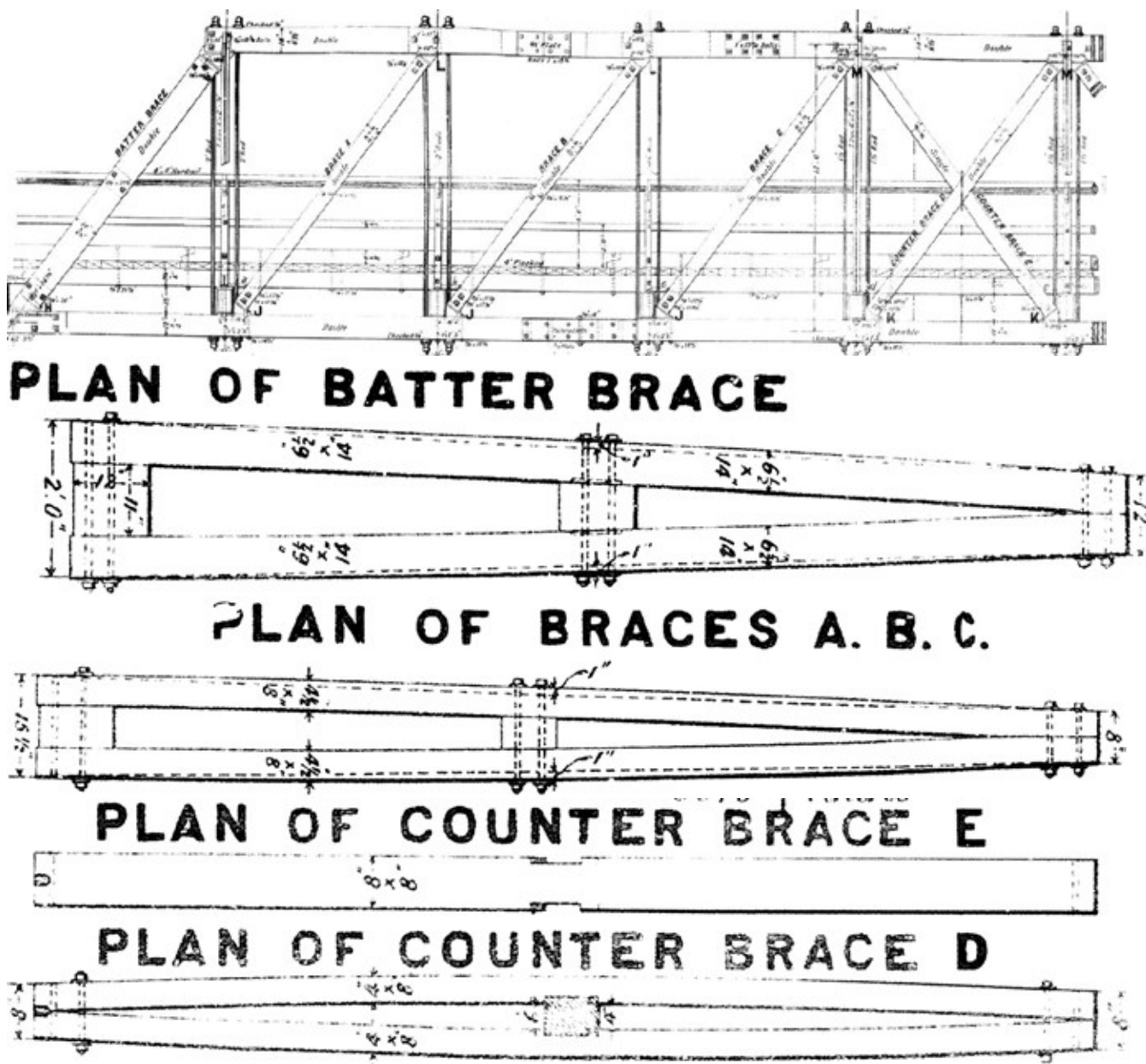

Source: 0612 496 BC 0000

There has been much enthusiasm about Allan and his Allan truss, reflected in statements such as, “Allan’s design unquestionably represents the pinnacle in the development of timber truss bridges in Australia.”⁵⁶ Taking Allan’s writings at face value would naturally lead one to think he was the most brilliant of engineers. Without disputing the fact that Allan was indeed an eminent and influential engineer, looking at his writings and his designs, it becomes clear that he only succeeded because was standing on the shoulders of giants (particularly Bennett and also McDonald) and he had astute engineers around him (such as de Burgh) to fix his little glitches.

⁵⁶ Rex Glencross-Grant, ‘The evolution of large-truss road bridges in NSW, Australia’ *Proceedings of the Institution of Civil Engineers*, Engineering History and Heritage 165 May 2012 Issue EH2, p 101.

Another interesting comment made by Allan is with regard to the timber decks:

*The flat decks in the old type of bridges resulted in water lying in pools on the surface of the planks, more especially in the centre of the roadway, where the wear is greatest; 3 inch (76 mm) scupper pipes along kerb line, even if not choked up, are therefore of little service.*⁵⁷

The original decking of the Allan truss consisted of tarred 4" (100 mm) thick timber planking which was laid transversely and was curved to provide a 1½" camber to ensure good drainage.

Scuppers (for drainage) were provided at the four corners of the truss span, consisting of 10" x 18" (254 x 457 mm) cast iron gratings set into wrought iron frames and connected to the outer stringers and additional timber beams provided for that purpose. That the original designers even considered providing drainage for timber decks should alert us to the fact that leaky timber decks today are very different to the timber decks originally provided on timber truss bridges.

The primary function of the deck is to carry traffic. Originally a tarred surface was provided in order to minimise the slipperiness of the exposed timber deck so that vehicles and cattle could cross safely as well as to provide a protection against water to maximise the durability of the timber deck. Much care was taken to achieve a smooth safe deck surface. This means that the aesthetic of the original bridge was considerably less determined by the timber deck (which was smooth and dark and visually recessive) and considerably more focused on the truss with its white-painted timber.

Figure 2.17 gives an indication of the original aesthetic of timber decks on timber truss bridges. The smoothness of the deck as well as the dark colour when compared with the trusses is striking. The fact that these timber deck details were used with very little modification (the earlier two designs had flat decks with diagonal planks, whereas the later three designs had cambered decks with transverse planks and generous scuppers) by all five timber truss designers indicates that the details worked well at the time in which they were used. This is a testament to the quality of the timber which they were using, as the timber available today does not achieve the same results.

⁵⁷ Percy Allan, "Timber Bridge Construction in New South Wales", 1895, p II.

Figure 2-17: Original timber deck on Tharwa Bridge, undated



Source: State Archives 6/17284

While the timber decks were essentially very similar between types of timber truss bridges as originally constructed, the cast iron components differed substantially between truss types. Allan describes his design innovations for the cast iron shoes in the 90' (27.43 m) Allan truss as follows:

With a view to renewals, the horizontal thrust from the braces (by which Allan means the principals and diagonals) is taken up by means of castings, having lugs 1½" (38 mm) deep let into the chords, and where two lugs are necessary it will be noticed that the deeper lug is at the back of the casting, so as to distribute the thrust over a larger area and reduce the risk of failure by shearing between the lugs.⁵⁸

These cast iron shoes also have not been without difficulty, frequently being found broken by brittle fracture. Allan himself reported in 1924 with regard to the Kempsey Bridge that, "During the erection of trusses, the lugs of a defective cast iron shoe carrying the heel of the batter brace of truss was sheared off, and to avoid the risk of further defective shoes, built-up shoes of wrought steel were substituted for the cast iron shoes... and have proved quite efficient in service."

The 16 ton traction engine turned out not to be the heaviest vehicle using the road. Percy Allan pasted some newspaper articles into his calculation book regarding heavy loads, one of which is copied in Figure 2.18 below, showing a 30 tonne wagon load. Despite the knowledge that heavier loads such as these were using the bridges, the design load remained the 16 ton traction engine.

⁵⁸ Percy Allan, "Timber Bridge Construction in New South Wales", 1895, p III.

Figure 2-18: A Great Load of Wheat: 313 Bags on a Wagon in 1916 (almost 30 tons in total)



Source: Percy Allan's *Calculation Book*, held by RMS Bridge and Structural Engineering, p 18, excerpt from "A Great Load of Wheat", *The Farmer and Settler*, Wednesday 5 January 1916, p 7

2.4.3 Distinguishing features of the Allan truss

The primary characteristics that distinguish Percy Allan's designs for the Allan type timber truss bridge from other timber truss types are examined in this Section (refer to definitions in Section 1.6.2, including Figures 1.12 and 1.13 for Allan truss terminology and Section 2.3 for other types).

Figure 2-19: Original 90' Allan truss with plan views of top and bottom chords

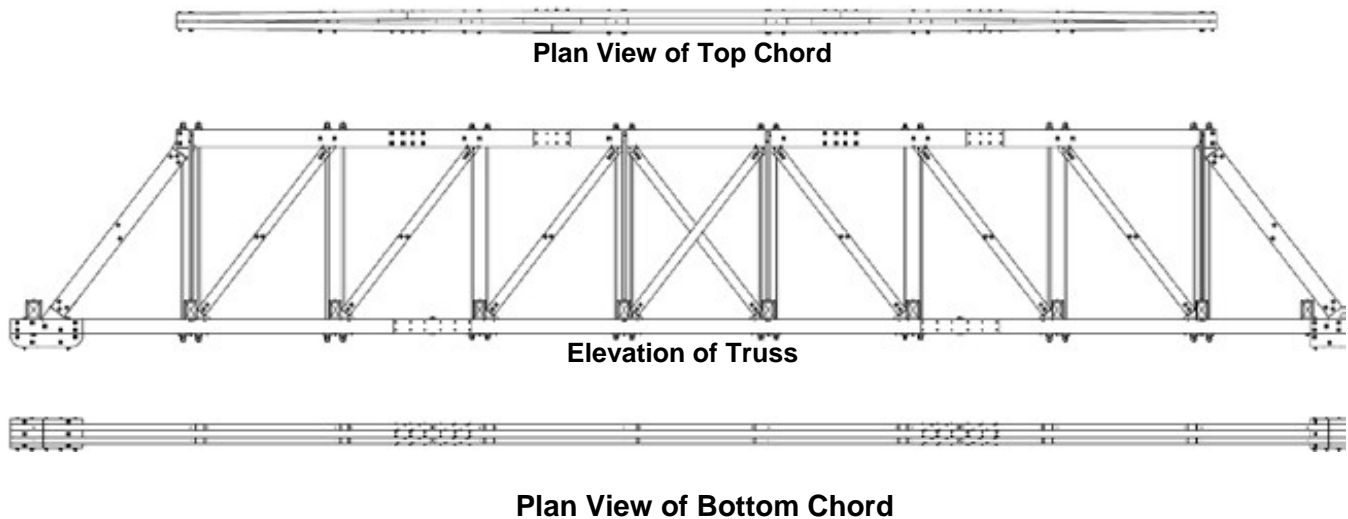

Source: Amie Nicholas

All the diagonals and principals in the Allan truss are placed at the same angle, which distinguishes them from the Old PWD and McDonald trusses. While Dare and de Burgh trusses have square panels (height and length are equal so diagonals are at a 45 degree angle), Allan trusses generally have rectangular panels which in the 90' (27.43 m) span are 10' (3.05 m) long by 13' (3.96 m) high.

As with the later truss types, counterbraces are only provided in the middle panel of the Allan truss, and the cross girders are only provided at panel points (there are no secondary cross girders).

All timber members consist of two timber flitches. Principals, diagonals and top chords consist of two flitches bowed around timber spacers to prevent warping and twisting. Bottom chords consist of two straight timber flitches with a gap to allow drainage, maintenance and air flow.

Instead of using a large number of bolts to transfer the tension force in the bottom chord, as was the theory behind the laminated timber bottom chord used in the Old PWD and McDonald truss, the Allan truss makes use of a special splice invented and tested by Allan to take the load.

Wrought-iron tension rods are located in pairs on either side of cross girders, passing through the space between the two flitches of the chords, eliminating bored holes through chords. The tension rods are designed in two sizes, with the larger tension rods located towards the ends of the spans.

Cast-iron shoes are provided at the top and bottom of all diagonal members. The horizontal forces from the principals and diagonals are transferred through shear lugs cut into the chords (Fig 2.21).

Although Percy Allan attempted to do away with the sway braces, iron T sections were generally used for sway braces, with sway bracing sometimes provided at all panel points, and sometimes only at selected panel points. At Victoria Bridge, four sway braces were provided for each truss, one at each end of the top chord, and two at the central two panel points.

Figure 2-20: Original design of Percy Allan's Allan truss bottom chord splice

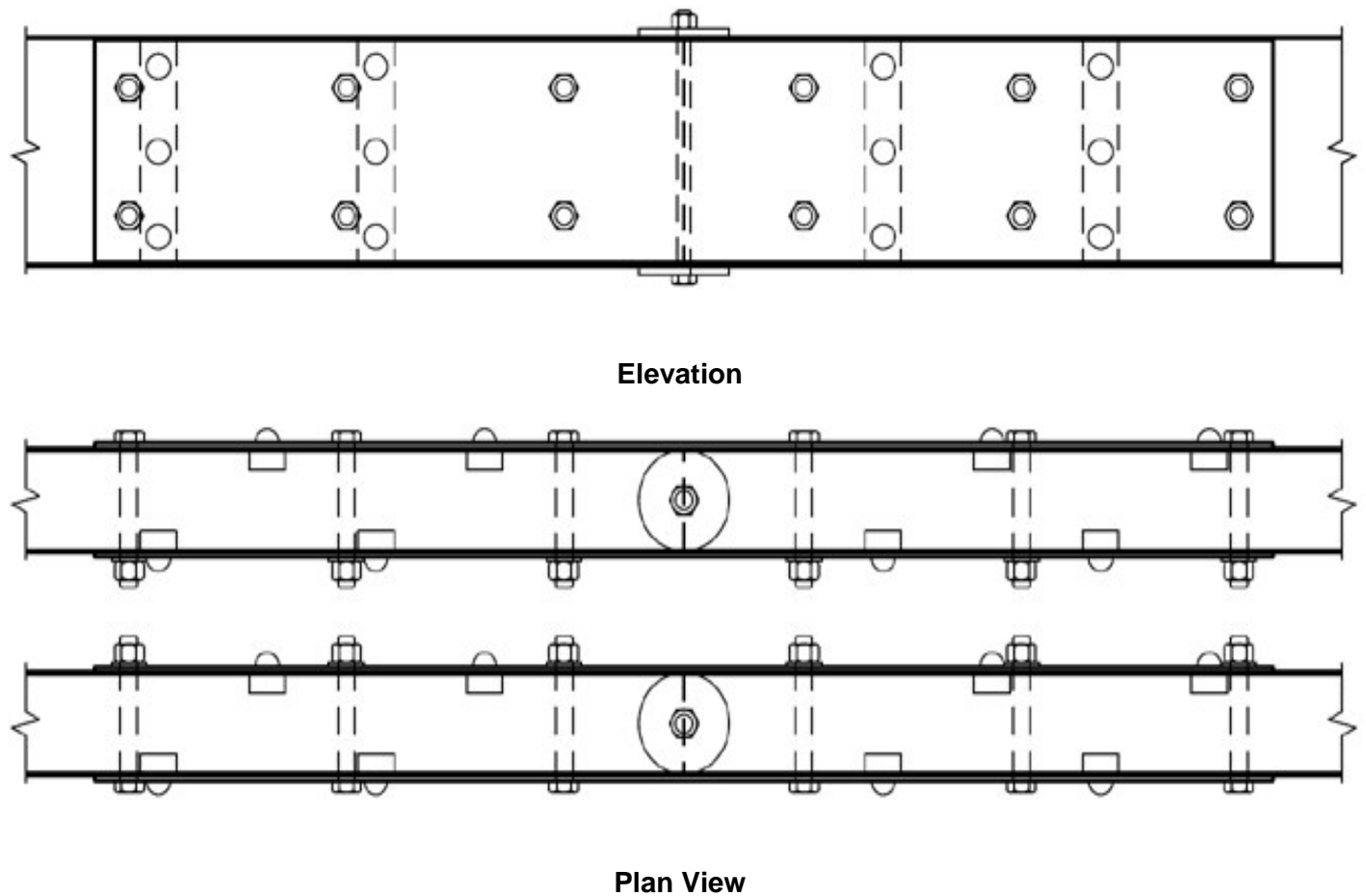

Source: Amie Nicholas

Figure 2-21: Original design of Allan truss top and bottom cast iron shoes

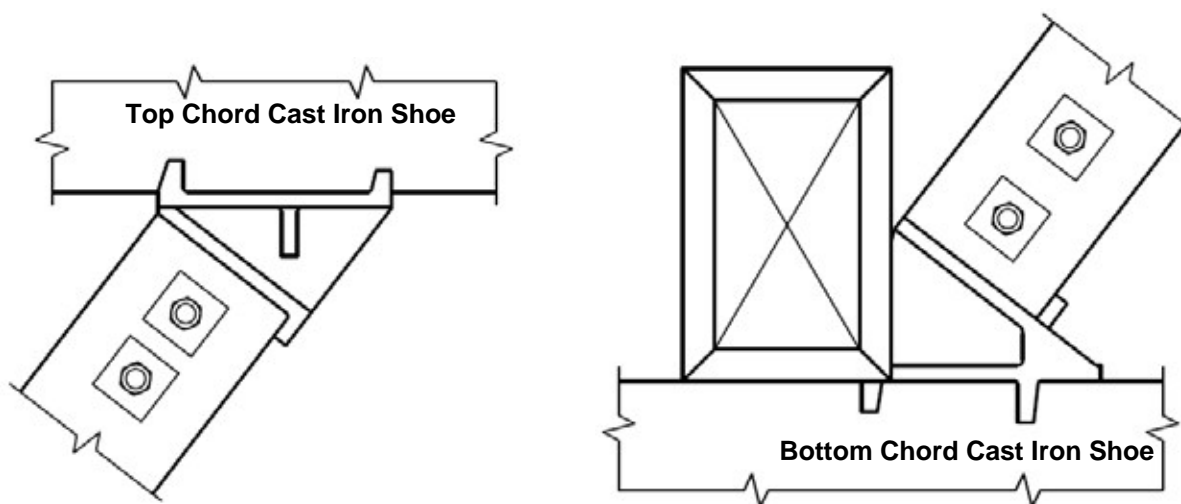

Source: Amine Nicholas

Typical of the later three truss types (Allan, de Burgh and Dare), the deck consists of transverse decking with two way cross fall. The transverse decking planks rest on longitudinal stringers which span between timber cross girders. Timber kerbs and Ordnance style timber railings are provided.

Figure 2-22: Original design of Allan truss shown in section at end of top chord

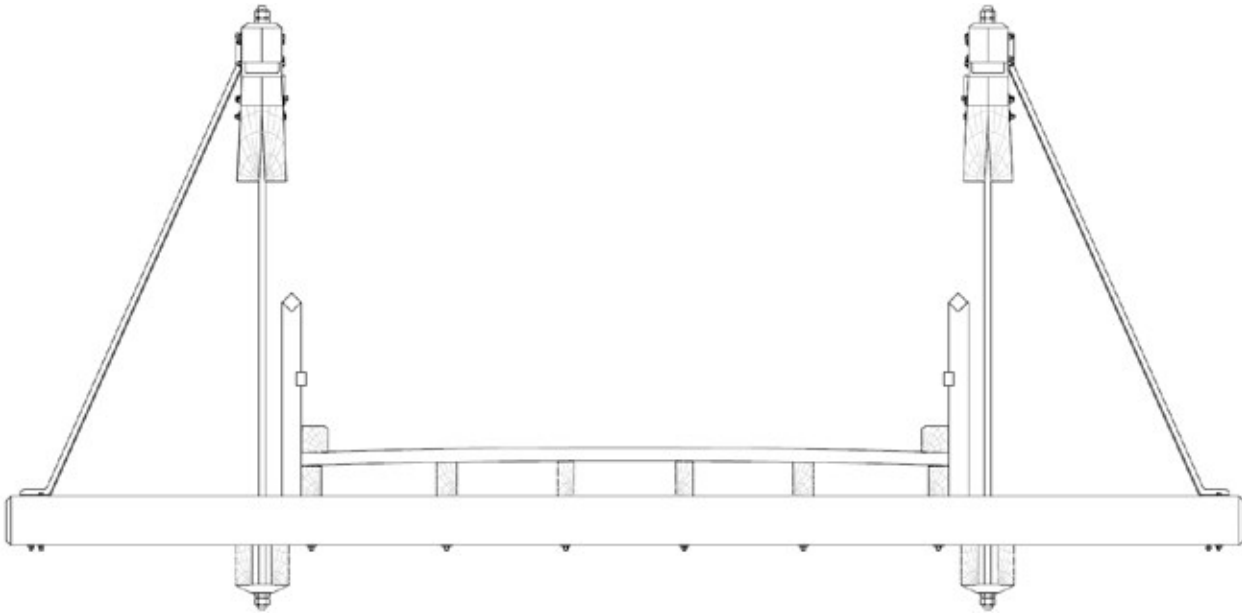

Source: Amie Nicholas

2.5 History of the area around Victoria Bridge

2.5.1 Indigenous and early European settlement

The Gundagurra Aboriginal people were the original inhabitants of the territory that stretched from the Razorback Range, south-west to Goulburn and west to the Burratorang Valley. They were not an isolated group but had regular communication with their neighbours, the Tharawal, the Dharug, Illawarra and Mountain peoples. Early European explorers not only relied heavily upon their Aboriginal guides but left accounts of the abundant wildlife in the bush, rivers teeming with fish, eels and yabbies and of the Aboriginal ingenuity in living in a seemingly harsh environment.⁵⁹

Official accounts that recorded the distribution of blankets in the 1840s and 1850s noted several groups of Aboriginals at Camden Park, Picton and the Burratorang Valley.⁶⁰ Today the cave and rock drawings of these inhabitants are carefully concealed in order to preserve them.⁶¹

The area north of Picton was first referred to as The Cowpastures in 1795 after the discovery of a flourishing cattle herd not far from the Nepean River, comprised of animals missing from the original settlement at Sydney Cove (for map, see Fig 2.23). They were contained and allowed to breed there until the expansion of settlement. The importance of this event is described as follows:

The loss early in June, 1788, of the black Cape cattle (four cows and two bulls) landed from the First Fleet late in January, 1788, appeared to the young and ill-fed community at Sydney Cove as an “absolute disaster.” But the discovery in 1795 of several herds (totalling over 100 head) across the Nepean River, turned the disaster into perhaps the most splendid and important event of the early years of white

⁵⁹ McQueen, Andy, *The Life and Journeys of Barrallier 1773-1853*, Springwood 1993 cited by Elizabeth Villy in ‘Victoria Bridge over Stonequarry Creek at Picton, Historical Background, June 2017’.

⁶⁰ Villy, Elizabeth, *The Old Razorback Road: Life of the Great South Road between Camden and Picton 1830-1930*. Rosenberg Dural, 2011 cited by Elizabeth Villy in ‘Victoria Bridge over Stonequarry Creek at Picton, Historical Background, June 2017’.

⁶¹ Elizabeth Villy, ‘Victoria Bridge over Stonequarry Creek at Picton, Historical Background, June 2017’.

settlement in New South Wales, giving an insight and comprehension of the capabilities of this new country to maintain vast herds of excellent cattle.⁶²

Stonequarry Creek was named as early as 1798, but the waterway through Picton had been named Poppy Brook between 1802 and 1805 before the earlier geological title, Stonequarry Rivulet or Stonequarry Creek was again used.⁶³ Settlement began in 1822 when Governor Macquarie made three land grants, one of which was given to Major Henry Colden Antill who received two grants totalling 2,800 acres. His land stretched from the base of the Razorback Range to Stonequarry Creek.⁶⁴ This provides an historic link between Picton and the Engineers Australia through Major Antill's great grandson, James Macquarie "Jim" Antill (1912-1994), who was an eminent construction engineer, a stalwart member of the Institution for 50 years and its Sydney Division President in 1969.⁸¹ Across the creek Karl Ludvig Rumker, the official government astronomer, held 2000 acres with his southern boundary abutting the 1700 acres put aside for an eventual township. George Harper, a government employee, was the third grantee.⁶⁵

Figure 2-23: Map of The Cowpastures

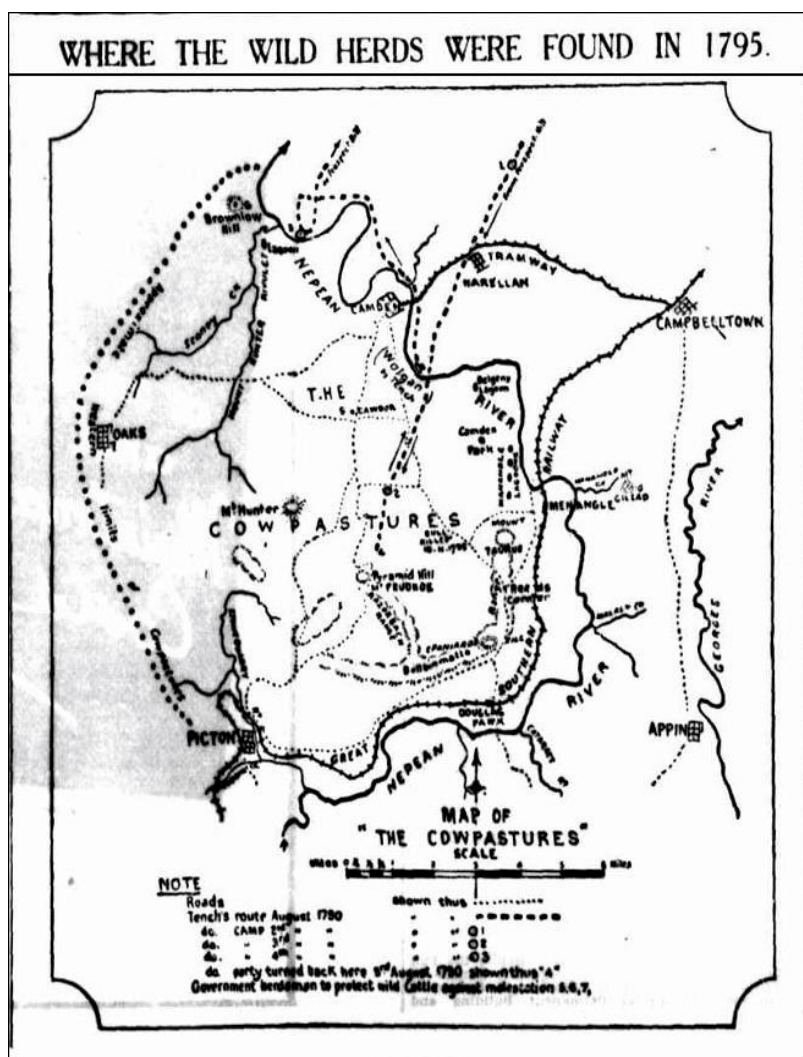

Source: *The Sydney Morning Herald* 13 August 1932, p 9

⁶² 'Disaster and its Sequel' by Burrenuick, *The Sydney Morning Herald*, Saturday 13 August 1932, p 9.

⁶³ Ross 1991 cited in Draft Conservation Management Plan for Victoria Bridge over Stonequarry Creek, Picton dated September 2003 prepared by Austral and GHD for RTA, p 9.

⁶⁴ Elizabeth Villy, 'Victoria Bridge over Stonequarry Creek at Picton, Historical Background, June 2017' ⁸¹ Don Fraser, Nomination of the Victoria Bridge Picton as an Historic Engineering Marker prepared for the Engineering Heritage Committee, Engineers Australia, 2003, from notes prepared by Jan Ross, p 9.

⁶⁵ Ross 1991 and Vincent 1995 cited in Draft CMP, September 2003, p 10.

2.5.2 Picton

The first major development that accelerated progress was the construction of the Great South Road that began in 1829 and completed in 1835. The road began at Campbelltown, then to Camden, over the Razorback and through Picton (then called Stonequarry) to Goulburn. The road opened up the country to the south and soon was busy with carts of tallow, wool, hides and other products to the Sydney docks. Travellers and migrants streamed to the newly opened country.⁶⁶

Figure 2-24: 1840s sketch of the Razor Back Road and the original direct line for the Great Southern Road with alteration proposed in favour of Camden



Source: State Library FL3692695

The map in Figure 2.24 above has been attributed to Mitchell, and shows the planned, but never constructed, section of the Southern Road from Campbelltown, via Appin and Pheasant's Nest Pass, two routes from Campbelltown over the Razor Back, one via Menangle and the other via Camden. Details in the map and the bridge illustration correspond to letters of 17 April 1830 from the Commissioners for

⁶⁶ Villy, Elizabeth, *The Old Razorback Road: Life of the Great South Road between Camden and Picton 1830-1930*. Rosenberg Dural, 2011 cited by Elizabeth Villy in Historical Background, June 2017.

Apportioning and Valuing the Lands of the Colony, one of whom was Mitchell, recommending the building of the Great Southern Road of this map and Mitchell's progress report of 1855 which recommends the building of wooden bridges. The sketch includes an illustration of a laminated timber arch bridge for the Pheasant's Nest.⁶⁷

Major Antill saw the opportunities offered by all this traffic and set about creating a private township on the southern end of his land at Stonequarry Creek. In June 1841 he advertised allotments for sale, the first one taken up a year later. The settlement around the creek and up the road was a straggle of bark huts, a makeshift gaol built of wooden slabs, a blacksmith and near Antill's home was a courthouse-cum-church. Across the creek, the New Inn, built in 1839, was an important incentive in the advertisements published in the Sydney newspapers. The settlement was known as Stonequarry but Antill changed this to Picton, an earlier name for the district.⁶⁸

Picton's development was hampered however by the competition between the private and government sites selected for various services. In 1845 the government gazetted the town of Upper Picton on the reserve some three kilometres south along the Great South Road. Major Antill, and later his son, John Macquarie Antill, countered this threat to their new, private town, by offering land to the government to build a new courthouse, gaol and police barracks as well as a public school. They also gave land to the Roman Catholic and Anglican churches.⁶⁹

Figure 2-25: The main street in 1905

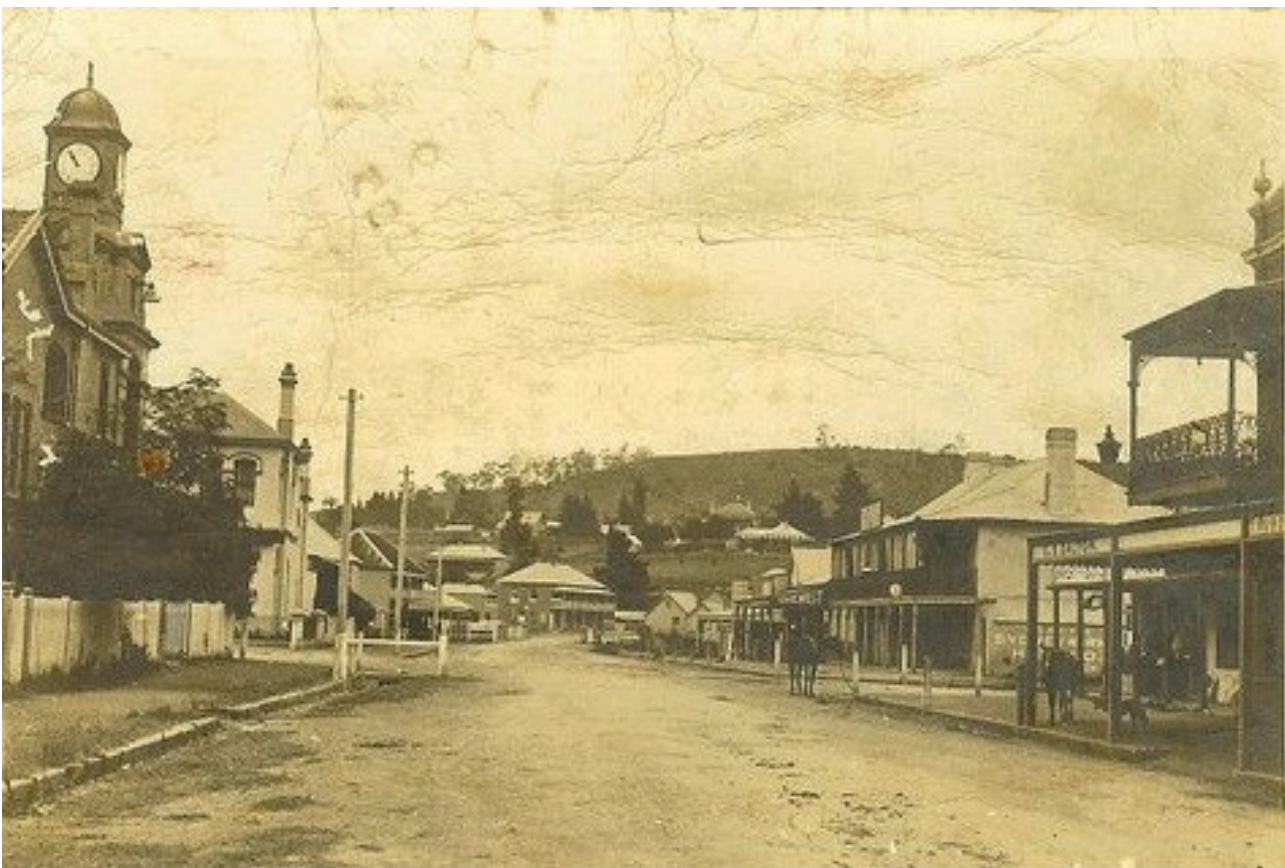

Source: Wollondilly Heritage Centre and Museum

⁶⁷ NSW State Library, catalogue notes accompanying FL3692695 which is shown in Figure 2.24.

⁶⁸ Villy, Elizabeth, *The Old Razorback Road: Life of the Great South Road between Camden and Picton 1830-1930*. Rosenberg Dural, 2011 cited by Elizabeth Villy in Historical Background, June 2017.

⁶⁹ Vincent, Liz, *The Forgotten Village of Picton, Introducing Upper Picton, Redbank, Picton 1995* cited by Elizabeth Villy in 'Victoria Bridge over Stonequarry Creek at Picton, Historical Background, June 2017'.

The Picton district was an attractive place to live and from the 1850s there was a steady increase in the population including migrants from Britain. It had clean air and a benign climate away from the smog and grit of Sydney along with steady employment prospects.⁷⁰ In its early days, Picton was surrounded by pastoral properties, dairies, farms and small holdings which still provide much of Picton's pleasant rural setting. However, with the arrival of the Great Southern Railway in 1863, it quickly assumed a railway image which dominated the town's activities for another sixty years.⁷¹ The Great Southern Line was one of three constructed in the 1850s and 1860s with the object of opening up the interior of New South Wales. The railway was critical for Picton because land sales had been spasmodic since the town was founded. John Macquarie Antill, magistrate, land owner and son of the original grantee Major Henry Antill, used all his influence to ensure that the line diverted from Campbelltown to Picton and then to Mittagong. He, along with James and William Macarthur of Camden Park, met opposition from Sir Thomas Mitchell, the Surveyor-General who favoured a direct line through to Bargo. However, Mitchell died in 1853 opening the way for the Macarthurs and Antill to influence the outcome to their own advantage.⁷²

The first train arrived in Picton on 1st July 1863 and transformed the town and district. Picton became a railway town and was to remain so for the next hundred years. The railway was built on the eastern extremity of Antill's land. It remained the terminus for the line for four years until the route was completed over difficult mountain terrain to Mittagong.⁷³ The crossing of Stonequarry Creek was part of the original contract for the railway line, but the first contractor failed and the now famous stone arch viaduct was built by Murnin and Brown from 1863 and completed in 1867. This Structure (Figure 2.26) is still in service, unlike the other contemporary stone arch viaducts by John Whitton on the Great Western Railway. They had been built for single tracks whereas the Stonequarry Viaduct had the distinction of being built for double tracks.⁷⁴

⁷⁰ Elizabeth Villy, 'Victoria Bridge over Stonequarry Creek at Picton, Historical Background, June 2017'

⁷¹ Don Fraser, Nomination of the Victoria Bridge Picton as an Historic Engineering Marker prepared for the Engineering Heritage Committee, Engineers Australia, 2003, from notes prepared by Jan Ross, p 9.

⁷² Villy, Elizabeth, *The Old Razorback Road: Life of the Great South Road between Camden and Picton 1830-1930*. Rosenberg Dural, 2011 cited by Elizabeth Villy in Historical Background, June 2017.

⁷³ Singleton, Centenary of the opening of the Southern Line to Mittagong Australian Historical Society Journal, Volume 4 Bulletin 309, 1963 cited by Elizabeth Villy in Historical Background, June 2017.

⁷⁴ Don Fraser, Nomination of the Victoria Bridge Picton as an Historic Engineering Marker prepared for the Engineering Heritage Committee, Engineers Australia, 2003, pp 11-13.

Figure 2-26: Railway Viaduct at Picton c. 1900



Source: Wollondilly Heritage Centre and Museum

The village of Upper Picton – or Redbank as it was originally known – predates the town of Picton when the area was surveyed in 1821 by Surveyor Harper, who had 1700 acres reserved for a government town.⁷⁵

On the 8th October 1845 a notice appeared in the Government Gazette announcing the establishment of the village of Picton on the site earlier earmarked by Harper. Two years later, in order to avoid confusion with the village a mile northwards on Stonequarry Creek, it was renamed Upper Picton.⁷⁶ In that year the Gazette advertised blocks of land for sale that varied in price from £3 to £8 or £9. Comparable sized blocks in Antill's village sold for £30. Until the advent of the railway in Picton, Upper Picton offered a serious threat to Picton with its cheaper land. However, as the Antills donated land for government buildings, authorities ignored the allocated portions in Upper Picton, for example, the site allocated for the courthouse which was eventually established in Picton, is now a public park.⁷⁷ There was a smouldering resentment among the people of Upper Picton that they were disadvantaged and this was exacerbated when the railway station was built, ostensibly half way between the two villages.

There were several trains a day both up and down the line and it was at Picton that a second engine was hooked on to haul the train up the steep gradients to Mittagong. Freight trains carried produce and livestock to Sydney and the docks giving local farmers easy access to markets that previously had been difficult to

⁷⁵ SRNSW, Harper's Fieldbook, reel 2624 cited by Elizabeth Villy in 'Victoria Bridge over Stonequarry Creek at Picton, Historical Background, June 2017'.

⁷⁶ NSW Govt. Gazette 19/3/1847 cited by Elizabeth Villy in 'Victoria Bridge over Stonequarry Creek at Picton, Historical Background, June 2017'.

⁷⁷ Vincent, Liz, *The Forgotten Village of Picton, Introducing Upper Picton, Redbank*, Picton 1995 cited by Elizabeth Villy in 'Victoria Bridge over Stonequarry Creek at Picton, Historical Background, June 2017'.

reach. It now took two and a half hours from Sydney by train whereas before it had taken two days with an overnight stop in a coach. When dairying became a major industry in the 1880s it was the rail that enabled local producers of fresh milk and other dairy products to get these to Sydney within a few hours.⁷⁸

By the end of the century Picton was well established with a branch of the Commercial Bank, a new Post Office, shops, inns and all services that the town and outlying farming community needed.⁷⁹ In 1895 the district was incorporated in a municipality that included Upper Picton. It was a rare event for a government township to be supplanted by a private one.⁸⁰

Figure 2-27: 1924 Map of the town of Picton showing Victoria Bridge between the former private and government town grids



Source: State Library of NSW

⁷⁸ Villy, Elizabeth, *The Old Razorback Road: Life of the Great South Road between Camden and Picton 1830-1930*. Rosenberg Dural, 2011 cited by Elizabeth Villy in *Picton, Historical Background*, June 2017.

⁷⁹ Vincent, Liz, *The Forgotten Village of Picton, Introducing Upper Picton, Redbank, Picton 1995* cited by Elizabeth Villy in *'Victoria Bridge over Stonequarry Creek at Picton, Historical Background*, June 2017'.

⁸⁰ Elizabeth Villy, *'Victoria Bridge over Stonequarry Creek at Picton, Historical Background*, June 2017'

2.6 History of Victoria Bridge at Picton

2.6.1 The need for the bridge

Stonequarry Creek effectively divided Upper and Lower Picton, denying easy access to services for those in both areas. The private town had developed in Lower Picton, where essential facilities such as the Post Office and railway station were located, and problems arose due to the development of the two competing settlements. By the 1890s these difficulties came to a head when the Post Office started to charge one shilling for telegram delivery to Upper Picton.⁸¹

The local press provided an outlet for airing such grievances including one instance where an anonymous resident of Upper Picton wrote stating that people living in that settlement felt abandoned by government authorities.⁸² Employees of the railways who lived in the upper town followed an indirect route to work via a long detour through Lower Picton, or else they would attempt to traverse the steep sides of Stonequarry Creek at a negotiable crossing place.⁸³

During heavy rain or flooding, which was endemic during the 1860s, the creek was impassable. Pedestrians could go through scrub and paddocks, cross over the creek on stones or walk along the rails over the viaduct, a practice that railway staff vainly tried to stop. On the southern side of the viaduct, now hidden in the grass, is a flight of some 30 steep, stone steps, the origin of which is unknown. Possibly they were made before the bridge to help pedestrians get to the station. For a journey less rough, it was a long way down the main highway, through Picton then up Menangle Street. For some this meant a hike of some five or six kilometres.⁸⁴

⁸¹ Vincent 1995, p 47, cited in Draft CMP, September 2003, p 11.

⁸² *Picton Penny Post* 8/7/1896 cited in Draft CMP, September 2003, p 11.

⁸³ Vincent 1995, p 47, cited in Draft CMP, September 2003, p 11.

⁸⁴ Elizabeth Villy, 'Victoria Bridge over Stonequarry Creek at Picton, Historical Background, June 2017'

Figure 2-28: Flight of steep steps down viaduct wall⁸⁵



Source: Charlotte and Emily Senior

James Hooke was an English migrant who had settled in Upper Picton and soon became an extensive landowner. He was active in civic affairs becoming the prime mover for a bridge to connect the station with Upper Picton. In August 1882, along with George Bell from the village and George Bradbury, a magistrate from nearby Myrtle Creek, Hooke met with local member John Kidd and Thomas Garrett, who was the former MP for Camden, to present a petition to the Minister for Works, Mr Suttor. The petition urged the minister to consider 'better communication to the station by the residents of Upper Picton.'⁸⁶ Five years later, in October 1887, Hooke welcomed the minister to Picton to discuss the matter of a bridge over Stonequarry Creek.⁸⁷

2.6.2 The design of the bridge

Initial plans for construction of a bridge over Stonequarry Creek, to be known as Victoria Bridge, commenced in 1891 with drawings prepared by John Alexander McDonald for a three span McDonald truss bridge designed to link Upper Picton to the Railway Station (Figure 2.29). Annual reports published by the Department for Public Works indicate that for the year ending June 1891, a sum of £1 1s 0d was spent on unspecified bridge expenses, most probably survey and design.

⁸⁵ Photograph provided by Elizabeth Villy.

⁸⁶ *Sydney Morning Herald* 5/8/1882 cited by Elizabeth Villy in 'Victoria Bridge over Stonequarry Creek at Picton, Historical Background, June 2017'.

⁸⁷ *Sydney Morning Herald* 31/9/1887 cited by Elizabeth Villy in 'Victoria Bridge over Stonequarry Creek at Picton, Historical Background, June 2017'.

Figure 2-29: General Arrangement for McDonald's 1891 Design

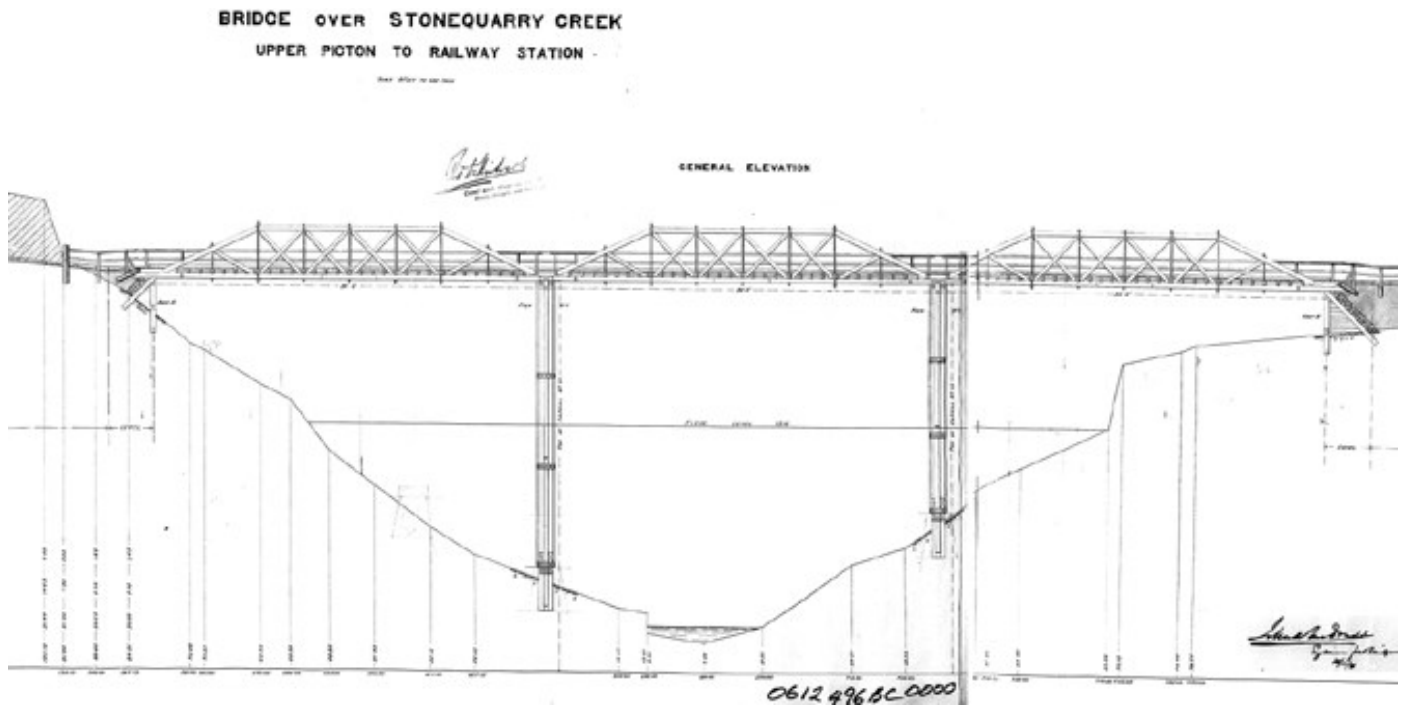

Source: RMS CARMS Id Number: 0612 496 BC 0000

During 1892-93 the sum expended was £90 16s 6d again unspecified but perhaps related to a far more elaborate design prepared by Percy Allan for a metal arch bridge (Figure 2.30) as well as the acquisition of land and the early tendering process. A notation on the town plan which dates from 1927 indicates that land on the western side of the creek was resumed as early as July 1892 for a bridge approach. Tenders were first advertised for a bridge in the early 1890s, but due to the lack of funds for public works at this time the process was not followed up.⁸⁸

The design for a metal arch bridge at Picton may have cost in the order of £11,000 to construct, which is almost three times the cost of the timber Allan truss design.⁸⁹ New South Wales was slowly recovering from the economic depression of the early 1890s and was experiencing one of its worst droughts. Funds for public works were constrained and the new timber truss bridges were proving to be very cost effective, so although metal arches were designed, they were not built.

⁸⁸ Draft CMP, September 2003, pp 11-12.

⁸⁹ Don Fraser, Nomination Historic Engineering Marker, 2003, p 10.

Figure 2-30: General Arrangement for Allan's 1894 Design

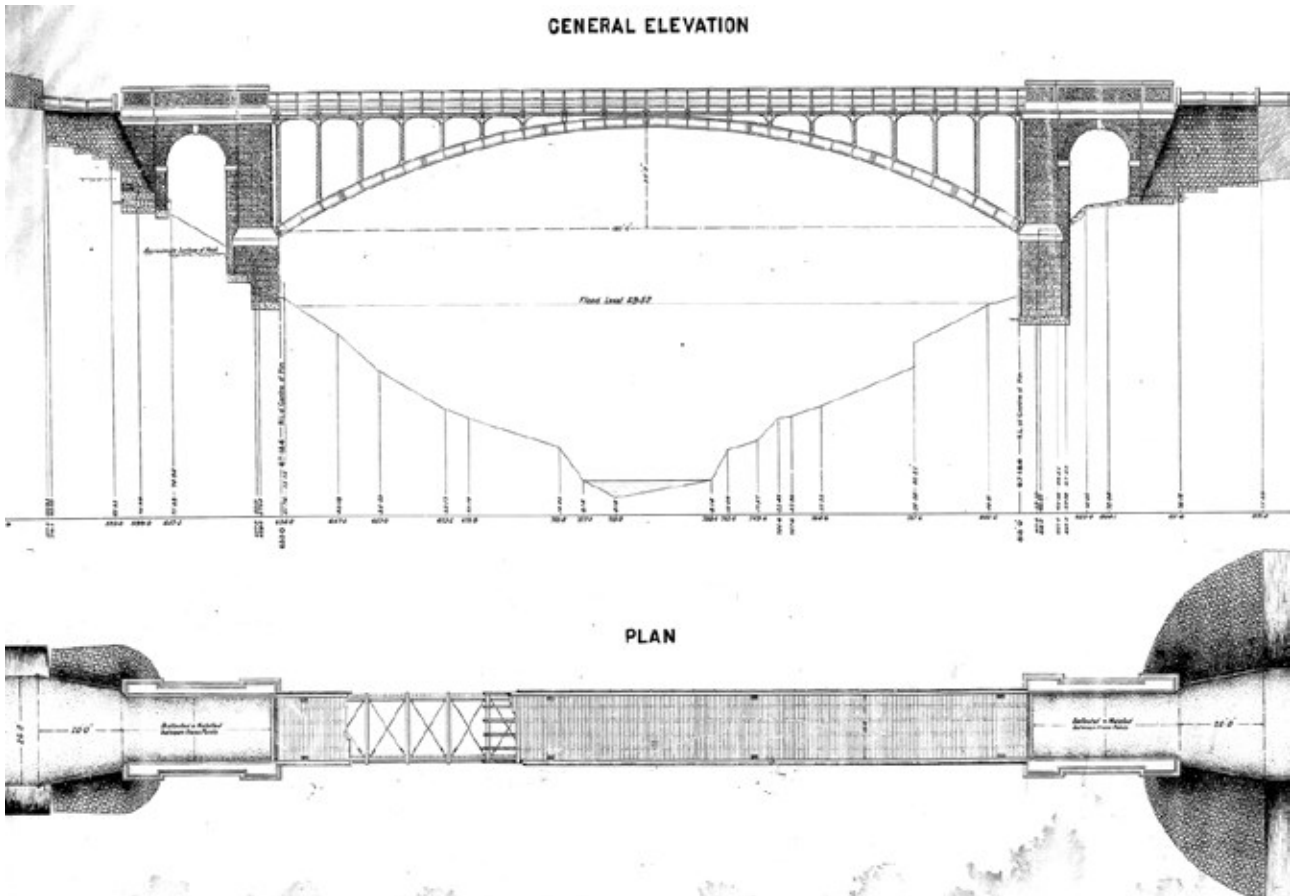

Source: 0612 496 BC 0000

Figure 2-31: Percy Allan's design development for metal arch options

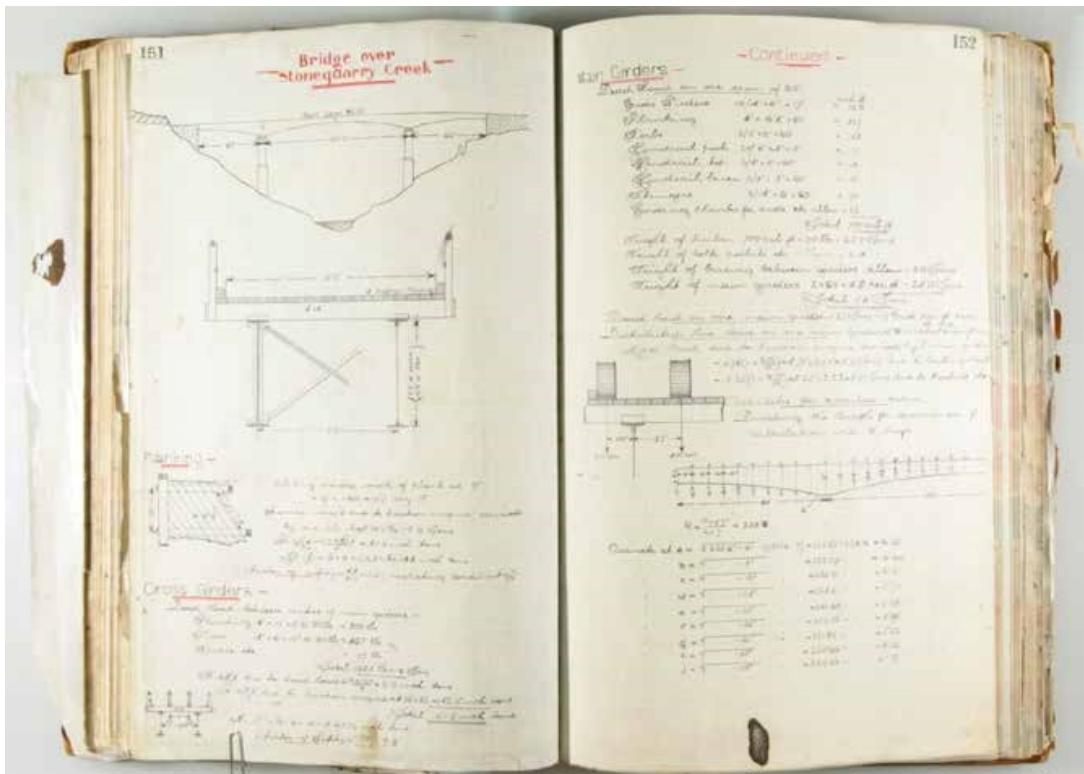

Source: calculation book

Figure 2-32: Percy Allan's design development for metal arch options

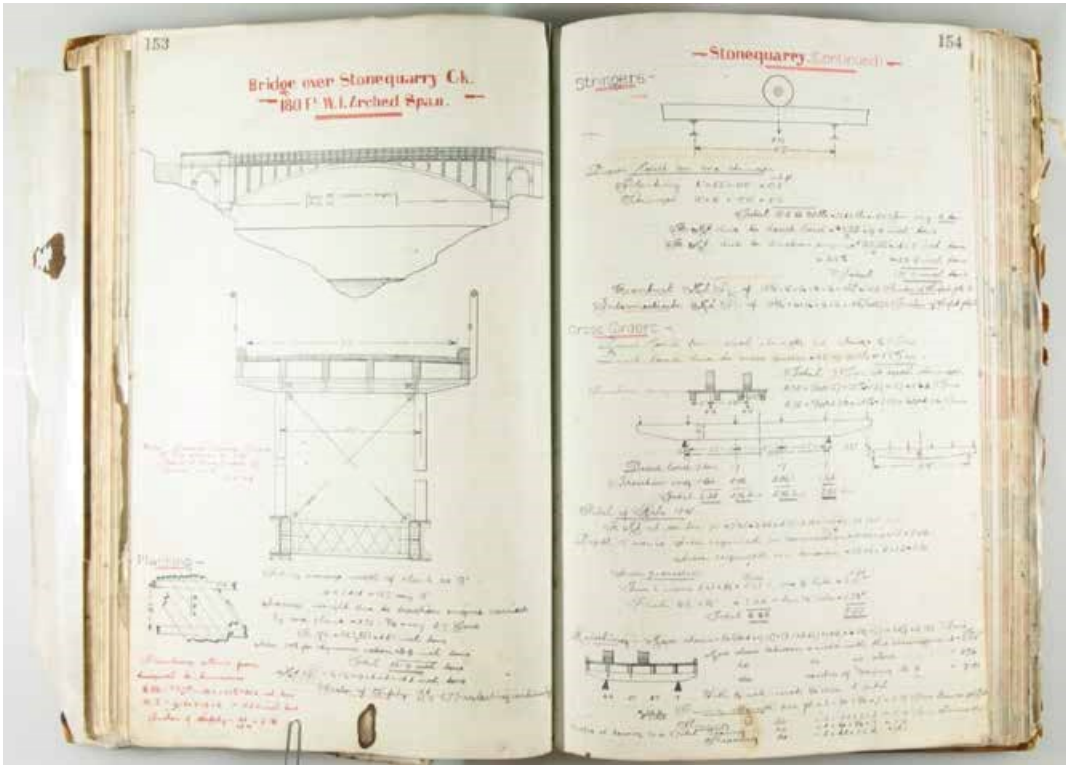

Source: calculation book

Virtually nothing further was spent until 1896-1897. In 1896 tenders for the construction of a bridge over Stonequarry Creek at Picton were invited once more, this time on the design shown in Figure 2.33. They were advertised in the Government Gazette in July and were to be accepted until early September.⁹⁰ A portion of land for a walkway to and from the bridge came from James Hooke, who had been instrumental in lobbying for the current line of the Bridge into Prince Street.⁹¹

Figure 2-33: General Arrangement for Allan's 1896 Design

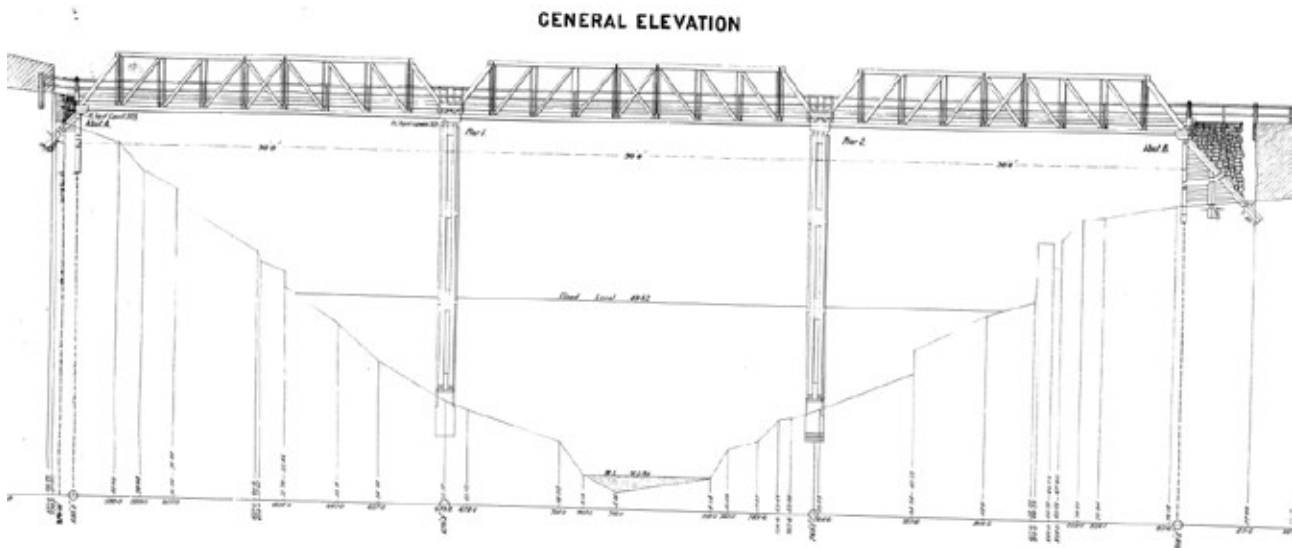

Source: 0612 496 BC 0000

⁹⁰ GG, 28/7/1896 cited in Draft CMP, September 2003, p 12.

⁹¹ Vincent 1995, p 48, cited in Draft CMP, September 2003, p 12.

2.6.3 The construction of the bridge

By November work on the Bridge had at last commenced with the contract let to C J Foord, Canterbury, Sydney, and work continued over the next year until it was completed late 1897 at a cost of £3659 11s 11d.⁹² News of construction commencing was met with enthusiasm, especially in Upper Picton. It was hoped that the bridge would revitalise this part of the town by allowing easy access to postal, judicial and banking services, and the local press reported soon after that:

*The old township has a future before it... There is a feeling that the place will go ahead at the expense of Picton proper but the sentiment is unsound. What will benefit Upper Picton must equally benefit the headquarters of the business people.*⁹³

Robert Hickson, M.Inst.C.E. Under Secretary for Public Works and Commissioner for Roads, described Victoria Bridge at Picton as one of the most important new bridges completed that year:

*Bridge over Stone-quarry Creek at Picton (Victoria Bridge). - This bridge, taken in conjunction with that built by the Railway Commissioners over the Southern Railway, enables traffic from the Main Southern Road, Bargo, &c., to reach the railway station at Picton by a much shorter route than heretofore, and has also greatly reduced the amount of traffic passing over the dangerous level railway crossing. The bridge consists of three truss spans of 90 feet (27.43 m) each... A remarkable feature in this bridge is the great height of the timber piers, the deck of the bridge being 92 feet (28.04 m) above the creek.*⁹⁴

2.6.4 The opening and naming of the bridge

The bridge was officially opened on Thursday 7 October 1897, with The Sydney Morning Herald reporting on the event as follows.⁹⁵

CHRISTENING A NEW BRIDGE. MR. YOUNG AT PICTON. PICTON, Thursday. A new bridge just completed across the Stone Quarry Creek, giving shorter access from Upper Picton to the railway station, was officially opened to-day by the Minister for Works (Mr. J. H. Young), Mr. Bull, the present member for this electorate, Mr. Kidd, the late member, and other guests were met at the railway station, and driven round the upper and lower towns. Mr. Young then formally opened the bridge by cutting a ribbon across it, and christening it Victoria Bridge, at the same time breaking a bottle of champagne. About 70 persons then sat down at a banquet of the bridge... Mr Young paid high compliments to the contractor, Mr Charles Foord, for the efficient manner in which he had always carried out his work, and the way he always treated his workmen. The bridge cost nearly 3,700, is 270ft. long by 15ft wide and is one of the highest bridges in the colony, being 92ft. high.

The local paper gave some additional details of the festivities. It seems that an opening ceremony took place in Picton attended by invited dignitaries and local onlookers. The official party moved to 'Glenside', the home of George Bell in Wild Street and there Mrs Bell put on a meal that drew admiration from the reporter of the local paper. 'Everything was in apple pie order and the spread was a credit to Picton.' Not so grand a spread was enjoyed by some 63 locals and pressmen who had their lunch in the middle of Victoria Bridge.⁹⁶ The name "Victoria Bridge" had some local controversy with some of the townsfolk

⁹² Vincent 1994, p 43, cited in Draft CMP, September 2003, p 12.

⁹³ PPP, 4/11/1896, cited in Draft CMP, September 2003, p 12.

⁹⁴ Report, Department of Public Works to the Legislative Assembly for the year ended June 1898, pp 12-14.

⁹⁵ *The Sydney Morning Herald*, Friday 8 October 1897, p 5.

⁹⁶ *Picton Post and Advocate*, 13/10/1897 cited by Elizabeth Villy in 'Victoria Bridge over Stonequarry Creek at Picton, Historical Background, June 2017'.

wanting "Hillgrove" the name of James Hooke's property, but the chosen name was in honour of Queen Victoria's 1897 Diamond Jubilee.⁹⁷

2.6.5 The repair and use of the bridge

An early photograph (1920s) of Victoria Bridge at Picton is shown in Figure 2.34 below, in which the bridge stands out, and can be viewed from any direction in the sparsely populated landscape.

Interest in the bridge and its picturesque setting dates from its opening (see Figures 2.36 to 2.38). As seen in Figure 2.35 the channel of Stonequarry Creek at this point forms a deep gully that has its own dramatic character, and only a few hundred metres downstream the railway viaduct also required massive brick piers to negotiate the creek.

Originally, the bridge did not have designated pedestrian facilities except for two pedestrian refuges which can be seen in Figure 2.44. That appears to have been sufficient, given the volume and speed of the traffic, but would have been an issue with motorized vehicles. It took until 1979 when a guardrail was installed along the bridge to provide a designated pedestrian facility. The guardrail remains today (see Figure 2.45).

The photograph in Figure 2.39 indicates that it was not only the newspapers that were interested in the bridge, but visitors to the Picton area would also have their photographs taken on the bridge.

Figure 2-34: View of Picton looking east, 1920



Source: National Library of Australia, 4039 Album 1001/42

⁹⁷ Don Fraser, Nomination Historic Engineering Marker, 2003, p 10.

Figure 2-35: Victoria Bridge about 1900



Source: Wollondilly Heritage Centre and Museum

Figure 2-36: A depiction of Victoria Bridge in The Town and Country Journal 23/03/1901, p 32



Figure 2-37: Victoria Bridge as photographed in The Town and Country Journal 8/02/1905, p 31

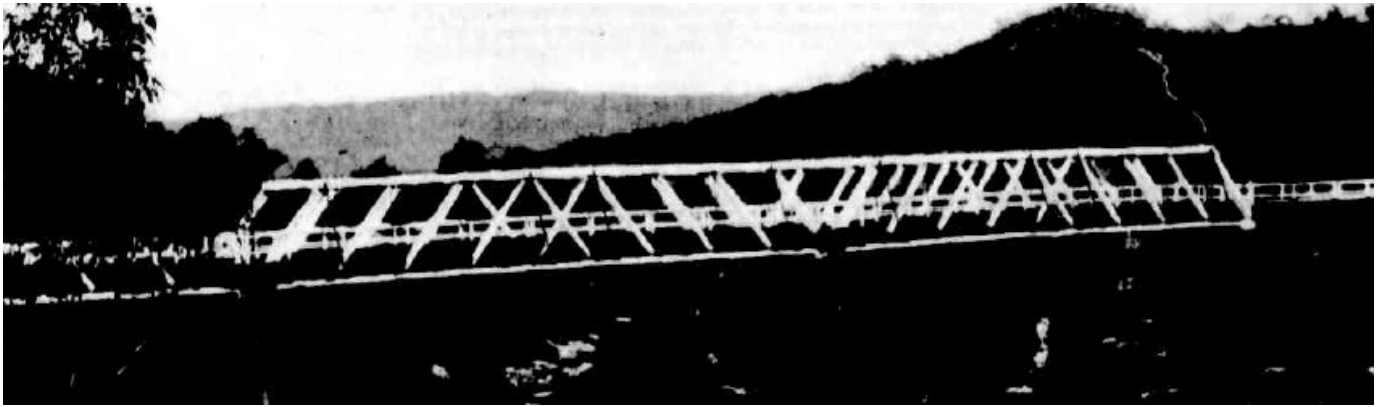

Figure 2-38: Victoria Bridge as photographed in The Town and Country Journal 31/10/1906, p 19.



In 1984, Victoria Bridge at Picton was listed by the National Trust, perhaps in response to some plans by Roads and Maritime's predecessor which had been in process since 1980 to replace the timber bridge with a concrete bridge in order to reduce the very significant maintenance burden. A letter was sent from the Wollondilly Shire Council to the Department of Main Roads (DMR) expressing concern regarding the intention to replace Victoria Bridge with a new concrete bridge and suggesting load limiting the bridge instead to reduce expenditure, stating that Victoria Bridge was too important historically to be merely dismantled or be allowed to deteriorate.⁹⁸

⁹⁸ From Wollondilly Shire Council Files, scanned copies provided by Anna Paul to Roads and Maritime.

The bridge therefore survived, and on 3rd October 1997 the Picton and District Historical Society organised a celebration of the centenary of the opening of the bridge in which people dressed in period costume and a procession of horse-drawn vehicles crossed the bridge.⁹⁹

Further celebrations occurred in 2003 with a heritage weekend on the 5th and 6th of April which included Engineers Australia recognising Victoria Bridge with a Historic Engineering Marker in the form of a plaque (Figure 2.40), some vintage cars driving across the bridge (Figure 2.41) and the launching of a self-guided tour for the southern highlands prepared by Roads and Maritime's predecessor (RTA), in which Victoria Bridge featured prominently on the front cover (Figure 2.42).

Figure 2-39: Visitors to Picton pre-WWI

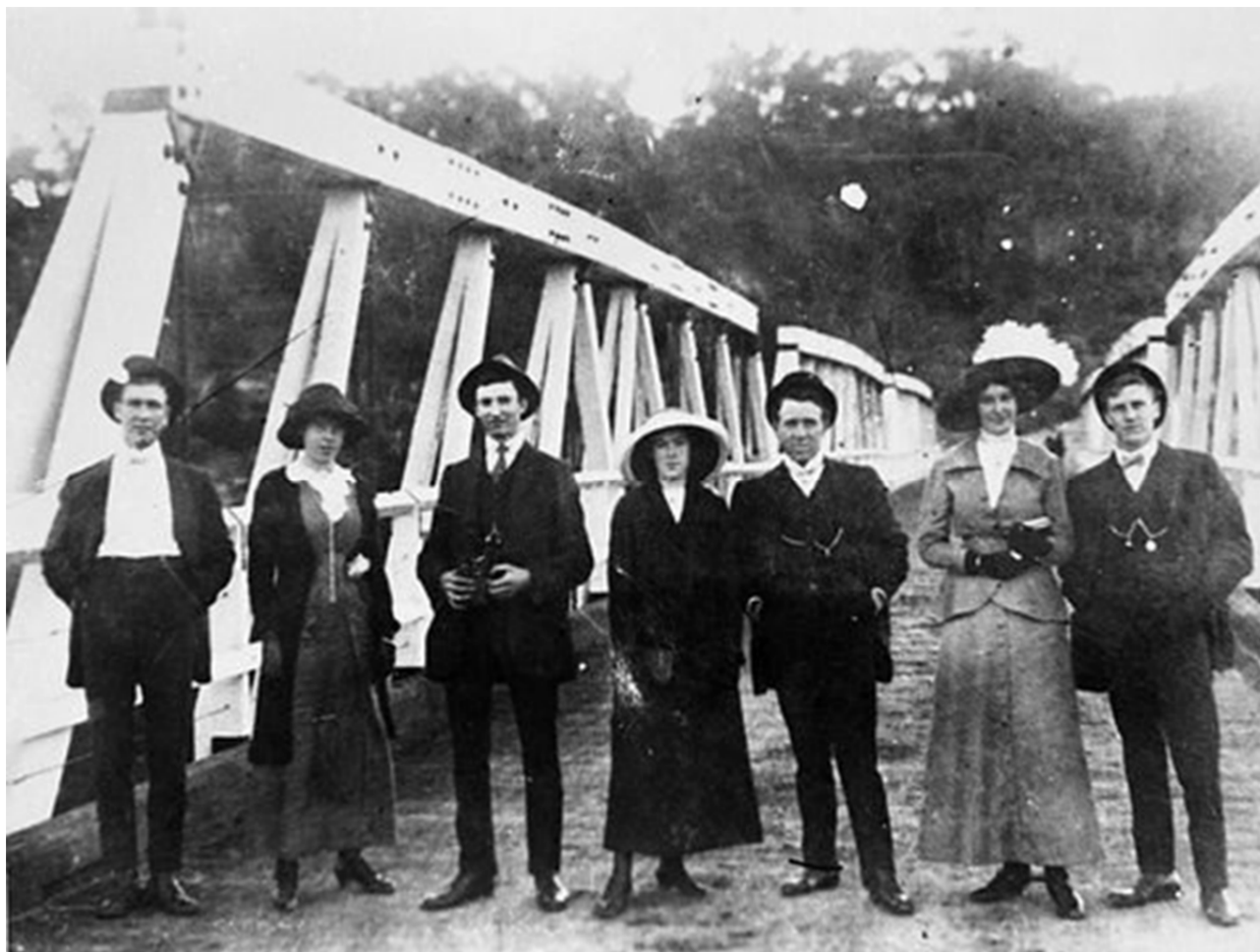

Source: *Wollondilly Heritage Centre and Museum*

Unfortunately, the Engineers Australia Historic Engineering Marker, which was to be installed on a stone block at the south west end of the bridge, has not yet been installed. The installation was waiting for the abutment rehabilitation to be underway, and was planned to be Roads and Maritime have stored the plaque for safekeeping and installation at a later date.

⁹⁹ *Macarthur Chronicle* 14/10/1997 cited by Elizabeth Villy in 'Victoria Bridge over Stonequarry Creek at Picton, Historical Background, June 2017'.

Figure 2-40: Plaque for the Bridge¹⁰⁰

Figure 2-41: Vintage Cars on Victoria Bridge¹⁰¹

Figure 2-42: Self-Guided Tour front cover picture¹⁰²



HISTORIC ENGINEERING MARKER
Victoria Bridge, Picton

PLAQUE WORDS

This bridge, opened on 7 October 1897, as designed by Percy Allan (1861-1930), an eminent Australian-born Public Works engineer after whom this truss type was named. The Allan truss was the third type in the evolution of timber truss road bridges in NSW. C J Foord of Sydney was the contractor for the bridge. Its 20 metre timber trestles are the tallest in NSW and it is one of the oldest surviving Allan pony truss bridges. It was named after Queen Victoria in her diamond jubilee year.

*The Institution of Engineers Australia
Roads and Traffic Authority, NSW
Wollondilly Shire Council, 2003*



Cr Col Mitchell, Mayor of Wollondilly Shire Council with Steve Finlay and Mal Bilaniwsky, Asset Manager Southern Region RTA.

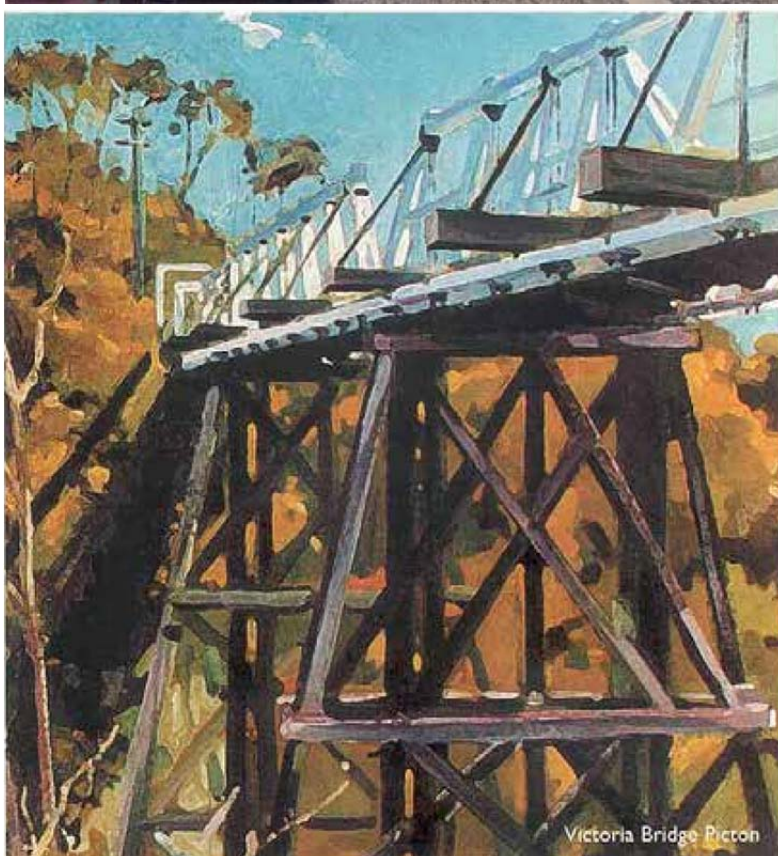

¹⁰⁰ Source: provided by Ken Maxwell of Engineers Australia, Engineering Heritage Sydney.

¹⁰¹ Source: photograph taken by Marlane Fairfax, and provided by Elizabeth Villy.

¹⁰² Source: Painting of Victoria Bridge at Picton by Ulf Kaiser for front cover of Southern Highlands Heritage Drives, Self-Guided tours produced by Roads and Traffic Authority (RTA), RTA/Pub.03.048, March 2003.

2.7 Operational Management History

2.7.1 Fire and water on the bridge

On Saturday 27th August 1966 a small scrub fire spread to the bridge and it seems the bitumen road surface (recently applied) caught alight. Firemen were rushed from Camden and Campbelltown to help the volunteers from Picton. Newspapers of the day variously recorded the fire as at one stage burning from end to end of the bridge or from the top to the bottom of the bridge.¹⁰³ The bridge was extensively damaged necessitating closure until 4th November when repairs had again made the bridge safe.

Another fire occurred on the evening of Friday 5th September 2003, apparently caused by a careless throwing of a cigarette butt from a car window, and was in the area where the principal from two trusses come together over the pier. Wollondilly Council was called out and erected barrier to stop traffic using the bridge. RTA staff carried out a preliminary assessment on the Saturday morning and as a consequence the bridge was closed to traffic and concrete barriers were erected to prevent unauthorised use of the bridge. The pedestrian footway was left open at that time, but a detailed inspection of the pier was carried out by rope access on Tuesday 9th September. This inspection established that a significant proportion of the bottom chords and the timbers that transfer the load from the truss to the pier had been burned. Figure 2.43 is a photograph taken that day, and shows that one of the bottom chords had burned right through and the other was badly damaged, meaning that the bridge could easily have completely collapsed. As a consequence, fences were erected preventing pedestrian access to the bridge also.¹⁰⁴

Figure 2-43: 2003 fire damage showing bottom chord damage



Source: Roads and Maritime

¹⁰³ Unsourced newspaper articles copied in Roads and Maritime, Wollongong Regional file 496.61 vol. 4.

¹⁰⁴ Roads and Maritime, Wollongong Regional file 496.61 volume 4.

While it was seven months before the bridge could be reopened to vehicular traffic, provision was made for pedestrians a little earlier by moving the footway temporarily from the inside of the truss to the outside (the temporary external footway provided after the 2003 fire is shown in Figure 2.46). This was achieved by replacing the short cross girders with longer cross girders as well as removing the original sway braces and installing a larger number of modified sway braces.

Figure 2-44: 1948 photographs of Victoria Bridge at Picton



Source: Government Printing Office 1 – 44224 State Library

Figure 2-45: 2013 photographs of existing Victoria Bridge internal footway



Source: author

Figure 2-46: Temporary external footway during 2004 repairs



Source: Roads and Maritime

More recently, it has not been fire that has been the problem but water. As early as February 2003 some bulging of the stone pitching at the eastern abutment had been noticed (Figure 2.47). Voids had developed behind the stones allowing backfill to settle and water to ingress and weaken the fill material. In 2007 there was a severe slip which damaged the abutment beyond repair (Figure 2.48).

Figure 2-47: Signs of failure of embankment beginning in 2003



Source: Roads and Maritime

Again, the bridge had to be closed to traffic for more than seven months while millions of dollars were spent in reconstructing a new embankment and abutment. Rather than building the embankment with rock fill as per the original design, a modern product called geofam was used because it required less excavation, did not load the abutment, was quick to install in any weather conditions and did not require compaction. The new abutment is also considerably different from the original in that the new abutment does not have potted piles, but is rather bolted with steel brackets to a concrete foundation which was constructed to support the new timber abutment.

Although the bridge is Roads and Maritime's responsibility, the embankment is owned by Council. As early as 1936 it was noted that stone pitching on the embanked formation had bulged out, and parts of it are still in poor condition today after various repairs have been made over the years.¹⁰⁵

Figure 2-48: Failed abutment and embankment due to slip in 2007



Source: Roads and Maritime

2.7.2 Closures of the bridge

Closures of Victoria Bridge at Picton have always caused considerable inconvenience to the locals who rely on the bridge for either vehicular, cyclist or pedestrian access. When the bridge had to be closed to both vehicles and pedestrians for a month during repairs in 1936 it was seen as an undue hardship, particularly

¹⁰⁵ State Archives, File ID 496.61 part 1, Wollondilly Victoria Bridge over Stonequarry Creek at Picton.

to the school children from Upper Picton who had to catch trains for school.¹⁰⁶ The following report was given in the local paper after a number of complaints:

At last week's meeting of the local council Mayor Eagles reported that he had interviewed the officer in charge of repairs at Victoria Bridge, respecting the closure of that structure against pedestrian traffic during repairs. It appeared that the risk of accidents was so great when the decking had to be removed that the proper course was being followed in order to prevent accidents. He felt sure that if suitable arrangements could be made by the Main Roads Department to assist pedestrians to cross, this assistance would be given.¹⁰⁷

Only two years before the 1966 fire, considerable repairs were undertaken so that the bridge was closed for approximately seven weeks during early 1964. A letter from the Divisional Engineer to the Shire Clerk explained that the closure was required due to the narrowness and the height of the bridge, which necessitated full closure whenever the deck is replaced, which is fairly frequently:

I wish to advise council that it is the Department's intention to carry out repairs to Victoria Bridge in the near future. Among other things it is proposed to remove the running planks, renew some structural members, the transverse deck planks and attach longitudinal sheeting. Because the bridge is narrow, high above the stream bed and the nature of the work, it is proposed to close it to traffic while the work on the deck is in progress.¹⁰⁸

Until the current alignment of the Hume Highway opened in 1980, the main street of Picton was a tangle of traffic chaos, often queued back for a mile or so and made worse by the 'Hole in the Wall' – the railway underpass to the south of the town.¹⁰⁹ There was all the highway traffic and many coal trucks, but after 1980 all was quiet with only local traffic on the road except for when Victoria Bridge was closed, which then caused diversion of cars back through the main street of Picton.

The traffic in the main street caused considerable problems for the local community and businesses during the four week closure of Victoria Bridge in 2001 which was required for lead paint removal as well as the longer emergency closures in 2004 and 2007.

Businesses in Picton are suffering because of the closure of Victoria Bridge, the Chamber of Commerce has said. The heritage-listed bridge has been closed for the past four months after a fire damaged several components and its closure is causing massive bottlenecks along Argyle Street... "we really need to get the Government moving along with Council to look at providing a proper bypass for Picton because the Victoria Bridge keeps getting closed all the time"...¹¹⁰

2.7.3 Noise from the bridge

Closures of the bridge are not the only thing that has caused considerable inconvenience to the local community. The noise created by heavy vehicles crossing over the bridge when the timber decking is a little loose and uneven has been a cause for considerable concern over the years. Figure 2.49 below shows an early (date unknown) photograph of the bridge in which the decking is very tight and smooth as per the original design and construction as described in Section 2.4.2. The original deck would have been quiet, but subsequent replacements have been less so.

¹⁰⁶ *Picton Post*, Wednesday 21 October 1936, p 1.

¹⁰⁷ *Picton Post*, Wednesday 4 November 1936, p 2.

¹⁰⁸ State Archives, File ID 496.61 part 1, Wollondilly Victoria Bridge over Stonequarry Creek at Picton.

¹⁰⁹ Roads and Maritime, *The Old Hume Highway, History begins with a road*, 2013, p 30.

¹¹⁰ *Wollondilly Advertiser*, Tuesday 13 January 2014 as copied in State Archives, File ID 496.61 part 1.

Figure 2-49: Early photo showing smooth deck, undated

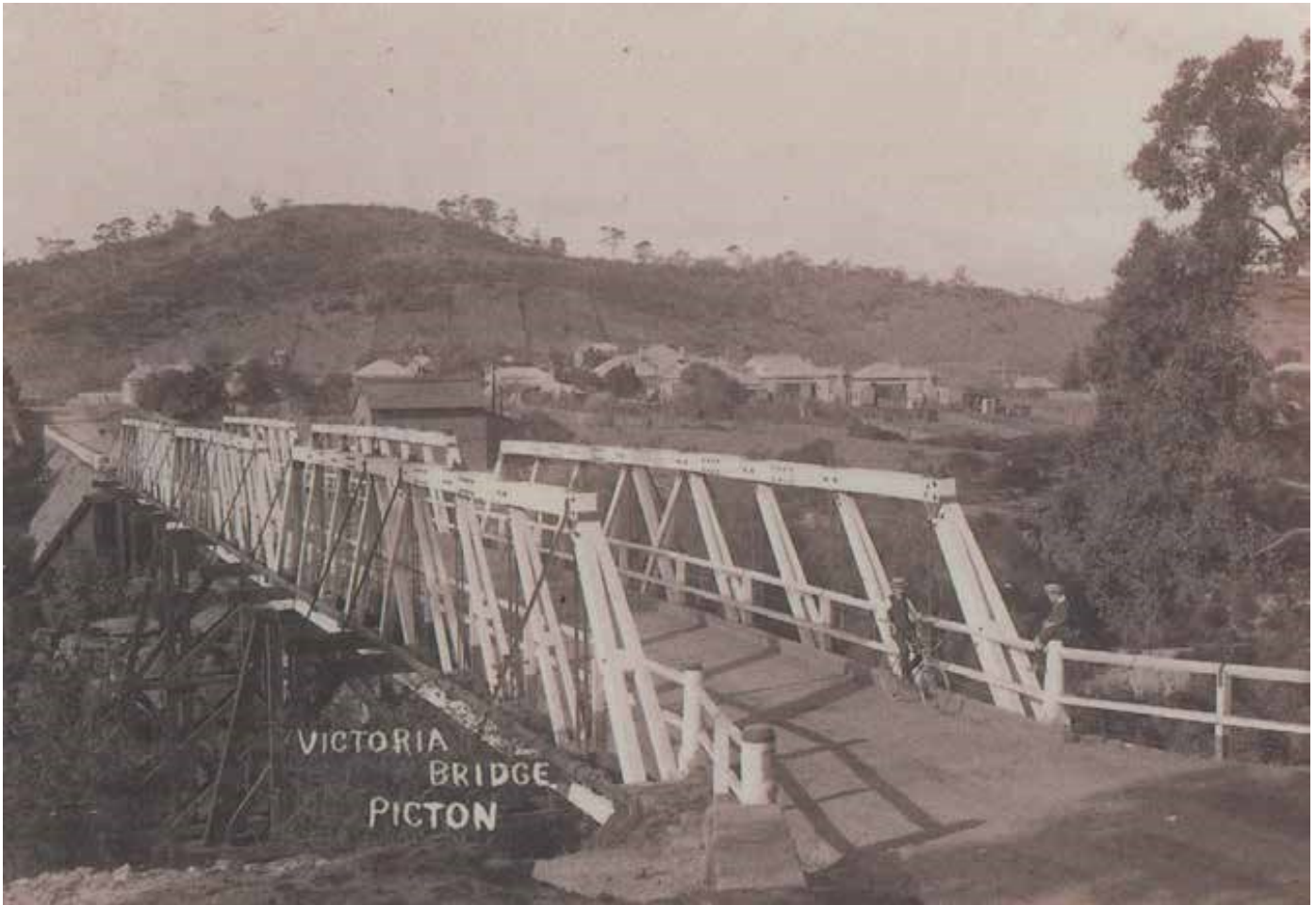

Source: Wollondilly Heritage Centre and Museum

A comparison between Figure 2.44 and Figure 2.49 shows that by 1948, the decking was very irregular, loose and rough. By 1951, the noise from vehicles crossing the bridge was causing sleepless nights for residents and much reduced quality of life. A letter from Shire Clerk to the Divisional Engineer stated that the condition of the decking was such that the spikes when hammered down loosened after the passage of only a small number of vehicles. The raised spikes caused damage to tyres and the noise of the loose planks to ratepayers was “extreme”.¹¹¹

*VICTORIA BRIDGE. The Noisiest Place in N.S.W. Victoria Bridge, Prince Street, Picton, was described at the October meeting of the Council for the Shire of Wollondilly as “the noisiest place in N.S.W.,” by Cr. S. Dogger. He also said Council would be quite within its rights to inform the Department of Main Roads that it would put the bridge up for sale if they didn’t give it some immediate attention and eliminate the excessive noise.*¹¹²

Despite efforts by the DMR to fix the problem by attaching longitudinal running planks (typical examples are Figure 2.50 below, also Figure 2.14), difficulties in obtaining suitable timbers meant that these could not be installed until late 1953. When they were finally installed, there was much relief, but the problem was then the slipperiness of the running planks as noted in the following:

The provision of longitudinal planks across this bridge has been very much appreciated by the Council and nearby residents, noise now being practically eliminated. However, I have been directed to invite

¹¹¹ State Archives, File ID 496.61 part 1, Wollondilly Victoria Bridge over Stonequarry Creek at Picton.

¹¹² Picton Post, 15 November 1951 as pasted in State Archives, File ID 496.61 part 1.

*your attention to the slippery nature of the longitudinal planks and to mention that in several cases, vehicles have left the longitudinal decking and had there been pedestrians crossing the bridge at the same time, accidents might have occurred. It is accordingly requested that the Department treat the new decking to make it non-slippery.*¹¹³

Figure 2-50: Typical Running Planks on Timber Bridge



Source: Roads and Maritime file 305.112

Due to accidents occurring on running planks on various timber bridges throughout the State these did not stay long, and were replaced with the new standard full width longitudinal sheeting at Victoria Bridge in 1964.¹¹⁴

For several years past, action has been proceeding throughout the State to attach longitudinal sheeting to decks of timber bridges on Main Roads. Timber bridges in the past were usually constructed with decks of planks placed transversely. This type of construction has become increasingly unsatisfactory under motor traffic, because the planks loosen by the driving wheels, and the consequent looseness and uneven riding surface in turn shake the entire structure of the bridge, loosening other members and causing noise when vehicles cross. By placing longitudinal sheeting above the transverse planks a surface is provided which is smooth and not affected by the tractive effort of the wheels... A possible disadvantage of the application of longitudinal sheeting over existing transverse planks is the likelihood of accelerated decay of the planks. It is believed that this will not be significant, however, because for the greater part, the bridges on which longitudinal sheeting is being attached will be replaced within the

¹¹³ Letter from Shire Clerk to Divisional Engineer dated 26 November 1953, State Archives, File ID 496.61 part 1, Wollondilly Victoria Bridge over Stonequarry Creek at Picton.

¹¹⁴ Conversation with former Chief Bridge Engineer Brian Pearson on 9 June 2017.

*next 20 years... To prevent the development of slippery conditions in wet or frosty weather, a bituminous surface, either flush seal or premix, is applied to the longitudinal sheeting.*¹¹⁵

It was not long before the “possible disadvantage” was realised, and the decking underneath decayed with rapidity. To improve the durability of the bottom layer of decking, gaps were introduced (approximately 30-50 mm) between transverse decking planks to allow improved drainage and ventilation. When longitudinal sheeting was introduced, spiking was no longer suitable, but the longitudinal sheeting was bolted to the decking. From underneath the bridge, this arrangement of bolted and spaced diagonal decking can currently be seen (Figure 2.51).

Despite these modifications to the deck, complaints regarding noise have continued with records of complaints having been received by the local Council in 1982 and again as recently as February 2016.¹¹⁶

Figure 2-51: View of existing bolted deck from beneath Victoria Bridge



Source: author 2017 - *Heavy vehicles on the bridge*

The other primary complaint with regard to Victoria Bridge is its use by heavy vehicles.

A water main was attached to one side of the bridge relatively soon after initial construction. The water main can be seen in Figure 2.49 and also in Figure 2.52 below. As early as 1926 the water main was leaking, causing damage to the bridge as well as disturbances to water supply, and the cause was considered to be “vibration from heavy lorries travelling over the bridge.”¹¹⁷

¹¹⁵ “Longitudinal Sheeting of Timber Bridge Decks”, *Main Roads*, Vol. 27, No. 4, June 1962, pp 123-124.

¹¹⁶ Email from Anna Paul of Wollondilly Shire Council to RMS dated 7 June 2017.

¹¹⁷ *Picton Post*, Wednesday 8 September 1926, p 2.

Figure 2-52: Early photograph of Victoria Bridge, undated

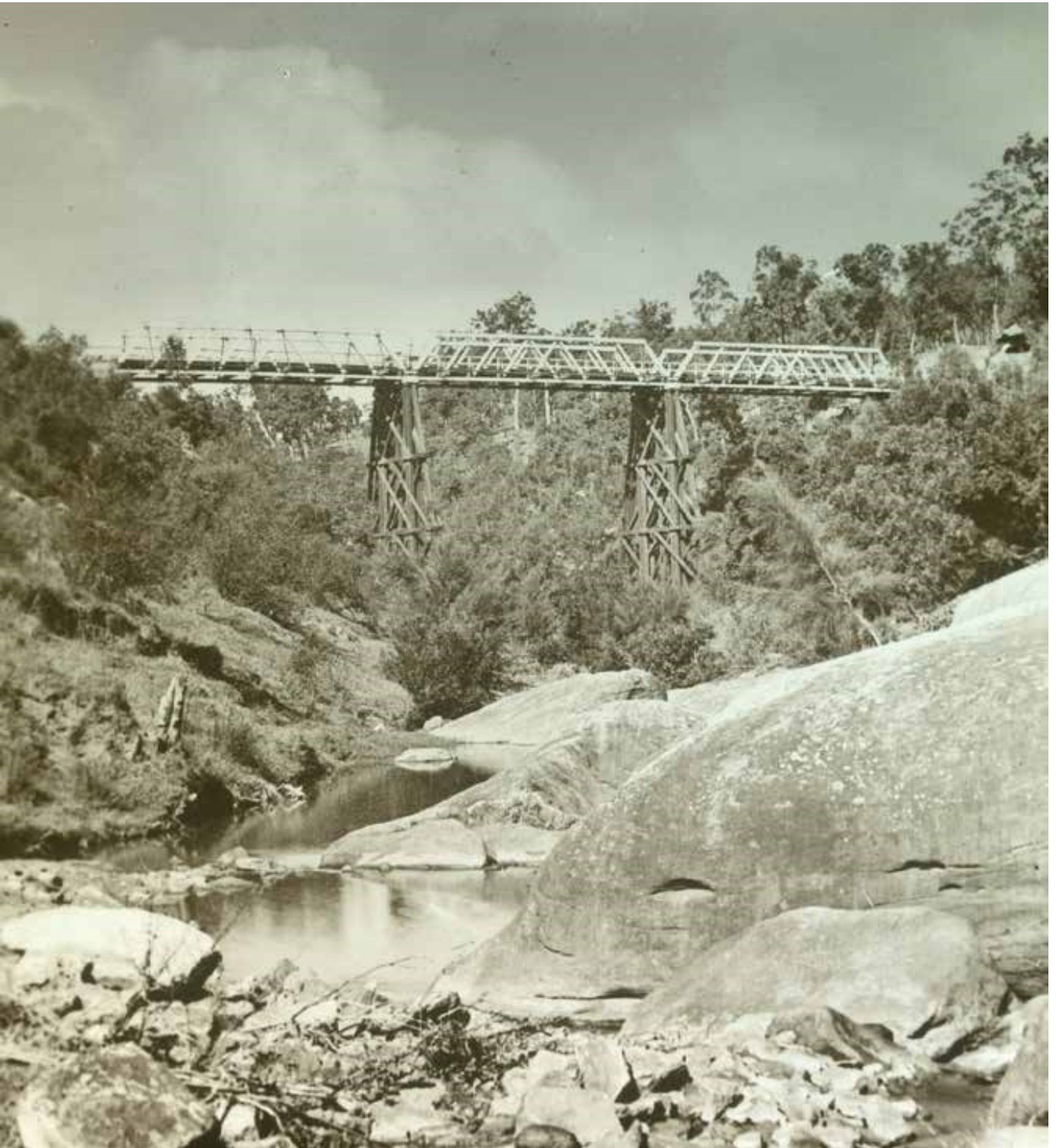

Source: State Library Victoria H91.300/150

In 1953 calls were made to apply a load limit to the bridge. This was largely due to difficulties in keeping the deck tight under these heavy loads causing the considerable noise previously mentioned. There was also a fear that these heavy vehicles were too heavy for the bridge.

HEAVY TRAFFIC THREATING VICTORIA BRIDGE. Council Seeks Ban. The movement of heavy traffic via Prince Street in Picton is seen by Wollondilly Shire Council as a threat to the safety of Victoria Bridge. Heavily laden trucks which travel along Prince Street are causing widespread damage to the

*roadway and present a continuous problem to maintain it in order... Councillor Sweet strongly urged that a complete ban should be placed on heavy traffic over Victoria Bridge.*¹¹⁸

A 15 ton load limit and 10 mph (16 km/hr) speed limit was applied. In 1964, Council decided to retain the weight limit on the road although the DMR removed the speed and load limit from the bridge. A letter from the Divisional Engineer to the Chief Engineer dated 4 June 1964 explained:

*The load and speed limits of 15 tons and 10 mph were imposed following your approval dated 25th May, 1951. At that time the deck planks were only spiked to the stringers and could not be kept tight due to the use made of the bridge by trucks hauling limestone to Maldon. In 1953 running planks were provided. The work now in hand is of a considerably higher standard... Maldon Cement Works are no longer supplied with limestone regularly by road vehicles. It is recommended that the load and speed limits... be reviewed.*¹¹⁹

However, in 1991, another letter from the Shire Engineer to the RTA requested a 5 tonne load limit and the installation of height restriction portals with the idea of reducing the maintenance cost:¹²⁰

"this would have the effect of extending the life of the structure as well as ensuring the safety of vehicles of heavier weights which may use the bridge inadvertently or otherwise."

Portal frames were designed to restrict the height to 2.2 m, but this was shortly increased to 2.4 m to allow for ambulances to use the bridge (Fig 2.53). When the fire service requested the height limit be raised to 3 m and the weight limit to 12 tonnes to allow the Fire Engine access, they were refused.

A letter from a local resident dated July 2005 noted, "The one-lane bridge, a vital traffic route, is of interest to heritage engineers because of its construction and to all residents and to others interested in heritage... Because some heavy vehicles were ignoring the 5 ton load limit, deterrent structures had been built at either end of the bridge and these are at present dismantled.

¹¹⁸ *Picton Post*, Wednesday 28 October 1953, p 8.

¹¹⁹ State Archives, File ID 496.61 part 1, Wollondilly Victoria Bridge over Stonequarry Creek at Picton.

¹²⁰ Roads and Maritime, Wollongong Regional file 496.61 volume 3.

Figure 2-53: Height restriction portals



Source: Amie Nicholas 2017

Heritage interested residents realise that some deterrents are necessary to stop the occasional “rogue” truck / semi-trailer drivers, otherwise even the renovated bridge structure may be weakened. But instead of the previous, ugly, “Christmas decoration” deterrent structures being replaced we are keen to have more heritage sensitive deterrents.”¹²¹

2.7.4 Accidents on the bridge

Despite speed restrictions, load limitations and the pedestrian footway, there is a long history of incidents and accidents at the bridge. A letter to Wollondilly Shire Council recorded a Magistrate commenting on the ever increasing number of accidents at the western end of Victoria Bridge, with particular reference to a court hearing regarding an accident at that location on 25th January 1975.¹²² Frequent complaints to the local Council of congestion have been occurring for the past ten years since the bridge last reopened after major repair works to the abutment. The congestion has reportedly led to daily accidents and there have been a number of calls for a second crossing.¹²³

¹²¹ Roads and Maritime, Wollongong Regional file 496.61 volume 4.

¹²² From Wollondilly Shire Council Files, scanned copies provided by Anna Paul to Roads and Maritime.

¹²³ Email from Anna Paul of Wollondilly Shire Council to RMS dated 7 June 2017.

Repairs and modifications to the bridge

A summary of repairs and modifications to the bridge found on the maintenance file is given in Table 2.1 below.

Table 2-1: Summary maintenance and repair history of Victoria Bridge

Year	
1924	Tenders called for provision of Brush Box decking, supplied by local Picton firm.
1927	Monitoring of overhanging tree, removal of sand from decking and replacement of missing notice to be sent.
1929	Letter from timber merchant stated that hewn ironbark 14"x7" free of heart was proving difficult to obtain and so they, "have been obliged to get trees specially cut to provide the timber. Several times after felling they were not considered good enough and owing to this trouble the execution of this order has been delayed".
1936	Repairs to piles in abutment A, wing pile at abutment B, truss members, long cross girders, stringers, transverse decking, paint kerbs, paint and tar areas of whole structure. Area of stone pitching of about 160 sq.yds bulged and should be re-set.
1940	Renewal of truss members, tightening of trusses, tightening deck and patch painting.
1941	Inspection recommends top chords be covered with galvanised iron to reduce water damage (unsure if this occurred), timbers tarred and bridge treated for termites.
1943/44	Replacement of timber members.
1949/50	Painting of piers with tar and cement, abutments also painted.
1950/51	Minor repairs.
1953/54	Longitudinal running planks fitted and coated with tar/sand to improve traction. Cracked cast iron truss shoes identified in 1936 repaired with external metal plates.
1960	Load limit lifted from 10 to 15 tons.
1963/64	Stringers, cross girders, bracing, piles, kerbs, full width longitudinal sheeting installed to replace running planks on transverse decking. Concrete fill placed at the bases of three new timber potted piles installed (centre Abutment A, two outer piles at Abutment B).
1967	Bridge damaged by fire, stringers, cross girders bracing replaced.
1971/72	Bottom chords renewed, cross girders renewed and replaced, concrete and stone retaining walls placed at both ends and 6" water pipe attached to replace existing.
1973	Bridge painted.
1976	1 metre wide footway proposed.
1976-1977	Test bore carried out – all stringers bored. Replace timbers on Pier 2, reinforce members of Abutment A, reinforce parts of Abutment B, replace cross girders, bracing

1978	Recommend replacement of downstream kerbing, 20% of longitudinal sheeting, clean and paint superstructure, erect chain wire on outer footway handrail. Reinforce braces.
1979	Internal footway constructed with guardrail (proposed 1953), as remains today. Pedestrian refuges were most probably removed at this time.
1980	Inspection recommends repairs to Piers 1 and 2 (timbers to be replaced).
1982/3	Replace top chord members, decking, kerbing and handrails. Miscellaneous repairs.
1984	Repair top timber rail on Span 2. Load limit 10 tonnes (gazetted as local thoroughfare)
1985	Tighten bolts.
1986	Inspection notes bridge in fair condition, with most elements considered sound.
1988	Visual inspection noted bridge in good condition. Vegetation clearing around bridge.
1990	Engineering inspection commissioned by RTA (carried out by Law, Matheson, Yttrup Pty Ltd). Results showed considerable rot in top chord of one truss span affecting the ability of outer chords to carry compression load and placing stress on other members.
1991	Bridge closed for 10 months for replacement of major timber members.
2001	Bridge closed for 4 weeks for lead paint removal and repaint.
2002	Installation of visually prominent flashing on the top chords as remains today.
2003	Damaged by fire on Saturday 6 September and closed to vehicles and pedestrians for many months, considerable repair works both due to fire and deterioration.
2007	Embankment and abutment failure at eastern end of bridge followed by replacement during seven month closure. Pedestrian facilities provided wherever feasible.

2.7.5 The bridge today

Victoria Bridge is still of substantial importance to the local and regional community, being highly esteemed for its historical value and its contribution to the town's sense of identity as a historical town. However, Victoria Bridge is also of substantial importance for its amenity, providing a vital link for pedestrians, and an important bypass to reduce congestion in the main part of town.

The narrow width of the bridge restricts it to a single lane of traffic, and with sustained population growth, congestion continues to increase especially in the morning and afternoon peaks, causing increased risks of incidents on the bridge and in the vicinity as well as increased difficulty in accessing the bridge in order to carry out necessary maintenance works.

Figure 2-54: Safety Warnings, Load Limits and Height restriction portals



Source: author 2017

2.8 Analysis of the existing fabric

2.8.1 Definitions of condition states for a timber truss bridge

Reference is made in this Section to an inspection carried out by Roads and Maritime on 1 March 2017.¹²⁴ This is the most recent of the regular inspections and was undertaken in accordance with the Bridge Inspection Procedure Manual.¹²⁵ In this inspection, each element of a bridge is given a “condition state” and these are defined in the following tables.¹²⁶

¹²⁴ Roads and Maritime, Bridge Inspection Report – Level 2 – Bridge No 965, 1 March 2017 (BIS).

¹²⁵ Roads and Maritime, *Bridge Inspection Procedure Manual*, second edition, June 2007.

¹²⁶ Roads and Maritime, *Bridge Inspection Procedure Manual*, 2007, chapter 4 (Timber), pp 2, 24, 36.

Condition State	Timber Elements of Timber Trusses – Condition State Descriptions
1	The timber is in good condition with no evidence of decay. There may be cracks, splits and checks having no effect on strength or serviceability. All connections are in good condition and bolts are tight.
2	Minor decay, insect infestation, splitting, cracking, checking or crushing may exist but none is sufficiently advanced to affect serviceability. Joint connections may be slightly loose but does not affect the serviceability.
3	Medium decay, insect infestation, splitting, cracking or crushing has produced loss of strength of the element but not of a sufficient magnitude to affect the serviceability of the bridge. Joint connections may be slightly loose but the serviceability of the bridge is not significantly affected.
4	Advanced deterioration. Heavy decay, insect infestation, splits, cracks or crushing has produced loss of strength that affects the serviceability of the bridge. Connections are very loose causing large movements, bolts are corroded and ineffective or missing, and the serviceability of the bridge is affected.

Condition State	Metal Tension Rods in Timber Trusses – Condition State Descriptions
1	The camber of the bottom chord is correct. There is no evidence of section loss.
2	The camber of the bottom chord is correct. Surface rust or minor pitting has formed or is forming. There is no measurable loss of section. There may be minor deformations that do not affect the integrity of the element.
3	Tension rods may need to be tightened to restore camber of bottom chords. Heavy pitting may be present. Some measurable section loss or necking is present locally. There may be missing locknuts but all connectors are in sound condition.
4	Tension rods may need to be replaced to restore camber of bottom chord. Significant section loss may be present. The tension rods may have stretched.

Condition State	Metal Shoes in Timber Trusses – Condition State Descriptions
1	There is no evidence of section loss or damage or cracks.
2	Surface rust or minor pitting has formed or is forming. There is no measurable loss of section. There may be minor deformations that do not affect the integrity of the element. There are no cracks in the metal. All connectors are in sound condition.
3	Heavy pitting may be present. Some measurable section loss is present locally. There may be minor cracks and/or deformations in the steel or welds. All connectors are in sound condition.
4	Significant section loss may be present. There may be cracks and/or deformations in the steel or welds. There may be numerous failed connectors.

2.8.2 Definition of heritage integrity for a timber truss bridge

Heritage integrity in the case of a timber truss bridge is best defined as the extent to which the existing elements are consistent with the original design in form, fabric and function.

For this reason, in order to assess the heritage integrity of Victoria Bridge, the following pages examine each element as it compares with the original. For each element, there is a detailed description of the original and a description of how the existing varies from the original due to modifications. The condition of each element is also provided in accordance with the definitions in Section 2.8.1. A summary of the condition and integrity of each element is given in Section 2.9.

2.8.3 Top chords

The top chords of the Allan truss are highlighted in Figure 2.55 below. The timber elements are highlighted in yellow and green and the metal top chord splice plates are highlighted in red. The letters in red relate to nomenclature of the inspection carried out on 1 March 2017.

Figure 2-55: Original 90' Allan truss design with top chords highlighted

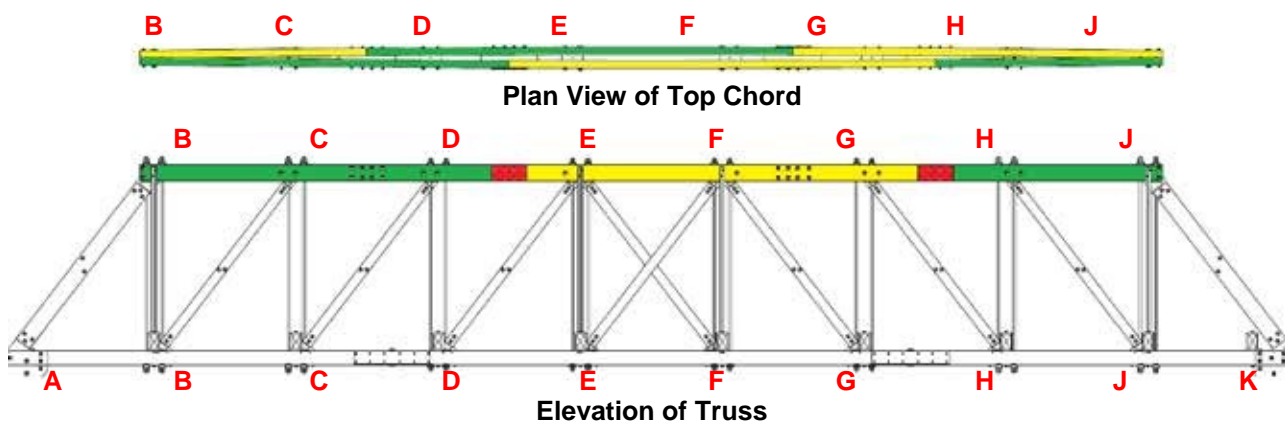

Source: Amie Nicholas

Original Design

Top chords consist of two rows of NSW hardwood timbers bowed around timber spacers to prevent warping and twisting. The original dimensions of the top chord timbers were 14" x 6½" (356 x 165 mm). Each row consisted of three lengths of timber with staggered joints covered with metal splice plates, as can be seen in Figure 2.55 above. The maximum gap between timbers was 5" (127 mm) at the centre of the span, with the gap reduced to zero at the ends. Four metal splice plates were provided (2 on each side), with a 4'0" (1219 mm) long timber spacer provided between top chord timbers at splice locations. 1'6" (457 mm) timber spacers were provided at panel points.

Existing Condition

None of the timbers in the top chords are original fabric, but they are all NSW hardwood. According to the most recent inspection all top chord timbers are rated as condition state 3. This indicates that timber has decayed (due to rot or termite attack), but the loss of strength is not of a sufficient magnitude to affect the serviceability of the bridge given the current 5 tonne load limit.

Analysis of Modifications

All of the top chord timbers consist of paired timbers as per the original design. However, only half of the top chords retain their original configuration. The table below compares the original and existing splice locations for each of the six top chords. Span 2 has had additional splices added both upstream and downstream (top chords consist of two rows of four lengths rather than two rows of three lengths). The top chord layout of the downstream Span 1 truss has also been substantially modified. Photographs of additional splices in Span 2 are given in Figures 2.56-57.

Table 2-2: Comparison of the original and existing splice locations for each of the six top chords

Span	U/S or D/S	Inner or Outer	Original Splice Locations	Existing Splice Locations (see Figure 2.55 for nomenclature)
1	Upstream	Inner	C-D and F-G	C-D and F-G as original
		Outer	D-E and G-H	D-E and G-H as original
	Downstream	Inner	C-D and F-G	B-C and E-F
		Outer	D-E and G-H	C-D and G-H
2	Upstream	Inner	C-D and F-G	C-D, F-G and G-H
		Outer	D-E and G-H	D-E, G-H and G-H
	Downstream	Inner	C-D and F-G	C-D, D-E and F-G
		Outer	D-E and G-H	D-E, E-F and G-H
3	Upstream	Inner	D-E and G-H	D-E and G-H as original
		Outer	C-D and F-G	C-D and F-G as original
	Downstream	Inner	D-E and G-H	D-E and G-H as original
		Outer	C-D and F-G	C-D and F-G as original

Figure 2-56: Additional splices at G-H in Span 2 Upstream



Source: Roads and Maritime

Figure 2-57: Additional splice at D-E in Span 2 Downstream



Source: Roads and Maritime

Where additional splices have been added, additional timber spacers have also been introduced, as can be seen in Figure 2.56. This has a deleterious effect on the top chords due to the number of additional timber to timber interfaces which have been introduced, which tend to exacerbate deterioration. Additional metal splice plates have also been provided at the new splice locations. These modifications detract from the structural integrity and the heritage integrity of the trusses.

Metal flashing has been added along the entire length in an attempt to protect the timber from water. It is likely that hidden deterioration would be occurring under the metal flashing. Flashing has been a popular experimental treatment for top chords of timber truss bridges, and Roads and Maritime has developed a number of different types of flashing which attempt to mitigate against the problems of moisture trapping and loss of air flow. However, it has become clear that flashing usually causes more problems than it solves. Flashing has a tendency to provide unwanted habitat for termites, wasps and micro bats, is an obstacle to regular inspections, it funnels water to gaps in flashing causing accelerated local deterioration and it detracts from the bridge aesthetics.

The flashing adversely impacts on the aesthetics of Victoria Bridge, particularly due to the large boxes which have been provided at tension rod locations, giving a castellated effect to the top chord which detracts considerably from the graceful curves of the original Allan truss design.

Figure 2-58: Visually dominant “castellated” flashing on top chords



Source: author 2013

2.8.4 Bottom chords

The bottom chords of the Allan truss are highlighted in Figure 2.59 below. The timber elements are highlighted in yellow and green and the metal bottom chord splice plates are highlighted in red.

Figure 2-59: Original 90' Allan truss design with bottom chords highlighted

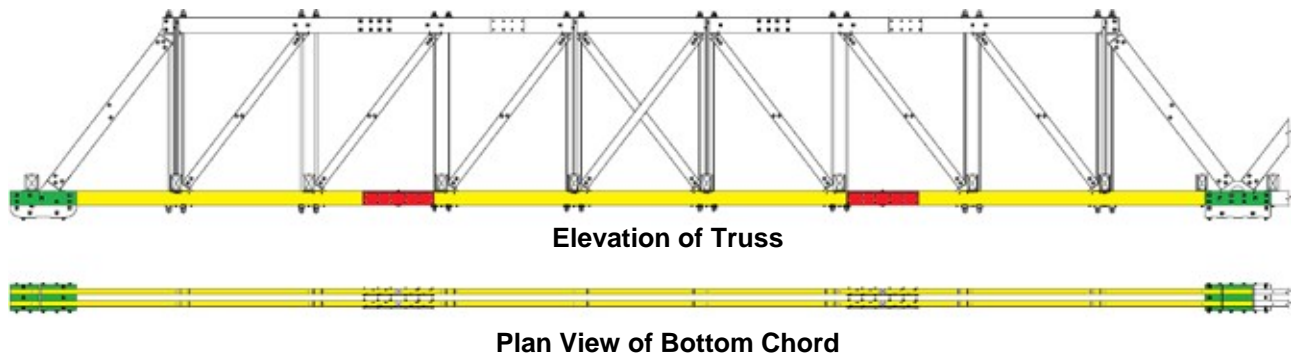

Source: author

Original Design

Bottom chords consist of two rows of straight NSW hardwood timber with a gap between them. The original dimensions of the bottom chord timbers were 12" x 5" (305 x 127 mm). Each row consisted of three lengths of timber with joints side by side, as can be seen in Figure 2.59 above. At the end of each span there are additional timbers on the outside of the bottom chord as well as timber packers between the bottom chord timbers (highlighted in green in Figure 2.59 above).

When Allan designed his Allan truss he was very conscious of the fact that it was becoming increasingly difficult to obtain long lengths of bottom chord timber, so he attempted to minimise the required length, "the longest flitch is only 36 feet (10.97 m), a length easily procurable".¹²⁷

There were two issues with this. The first, and most critical, is that in attempting to minimise the timber lengths, he located the splices very close to the cross girders. The interfaces between the timber cross girders and the timber bottom chords with their vertical bolted connections are highly susceptible to deterioration because moisture tends to accumulate at these locations. The splice locations are the areas of highest stress in the timber, and so any deterioration tends to cause a failure of the splice connection. The original proximity of the splice connections to the cross girders probably contributed to the early failures of Allan truss bottom chords as reported by Dare in 1904.

The second issue is that the original lengths are no longer easily procurable, and so in some bridges additional splices have been added, thereby increasing the risk of failure of the truss.

Existing Condition

None of the timbers in the bottom chords are original fabric, but they are all NSW hardwood. According to the most recent inspection all bottom chord timbers are rated as condition state 1, indicating that the timber in all the bottom chords is in good condition with no evidence of decay.

¹²⁷ Percy Allan, "Timber Bridge Construction in New South Wales", 1895, p VI.

Figure 2-60: Photograph of timber bottom chord taken from under bridge



Source: author 2017

Analysis of Modifications

All of the bottom chord timbers consist of paired timbers as per the original design. However, none of the bottom chords retain their original configuration, with all splice locations having changed.

For these reasons, the Roads and Maritime specification for timber truss repairs suggests that an alternative bottom chord tension splice layout may be used in lieu of the layout in the original drawings. This alternative symmetrical, non-staggered layout as shown in Figure 2.61 has one additional splice at mid-span and the maximum flitch length is reduced to 8.4 m to facilitate procurement.¹²⁸ It also locates the splices away from the cross girders to maximise durability.

The splice layout at Victoria Bridge reflects neither the original nor the approved alternative design, but rather, it varies from span to span and from truss to truss. All bottom chord splices have been moved away from cross girders towards the centre between two cross girders, but have been located in such a way that they are no longer symmetrical about the centre of the truss, and the upstream and downstream trusses no longer have a matching layout.

¹²⁸ Roads and Maritime QA Specification M757, Timber Truss Repairs – Construction, 2008.

Figure 2-61: Comparison of original and alternative bottom chord splice layout

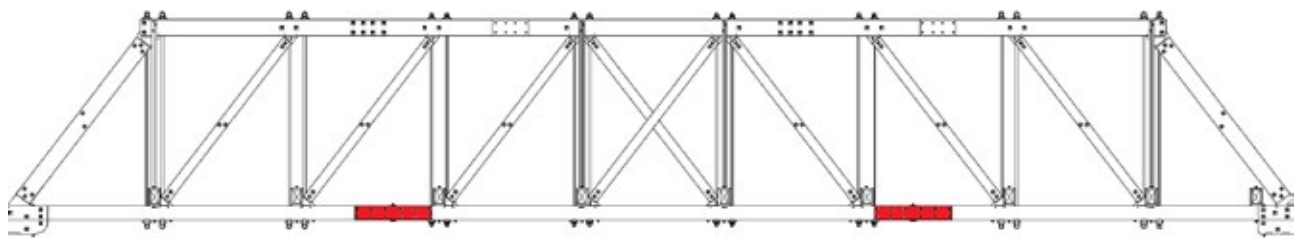

Original Splice Layout

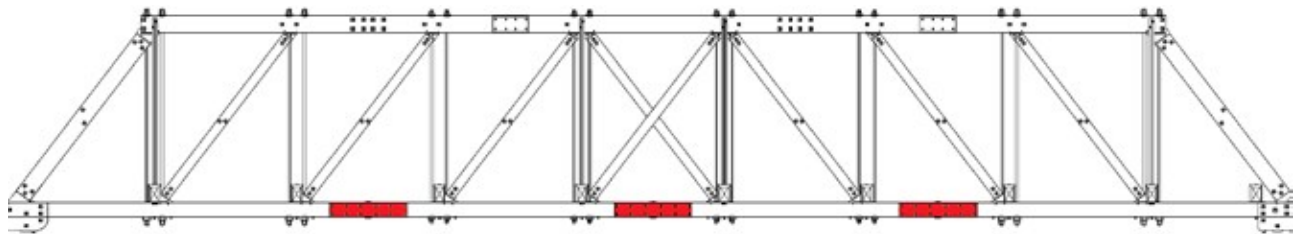

Alternative Splice Layout

Source: author

Views to bottom chords are somewhat obscured by monorails required for maintenance, and both top and bottom chord splices have always been painted white (rather than the more typical black) at Victoria Bridge, so the modifications to the bottom chords would not be obvious to most people viewing the bridge. However, these modifications detract from the heritage integrity of the trusses.

2.8.5 Principals and diagonals

The principals (green) and diagonals (yellow) of the Allan truss are highlighted in Figure 2.62 below. The letters in red relate to nomenclature of the inspection carried out on 1 March 2017.

Figure 2-62: Original 90' Allan truss design, principals and diagonals highlighted

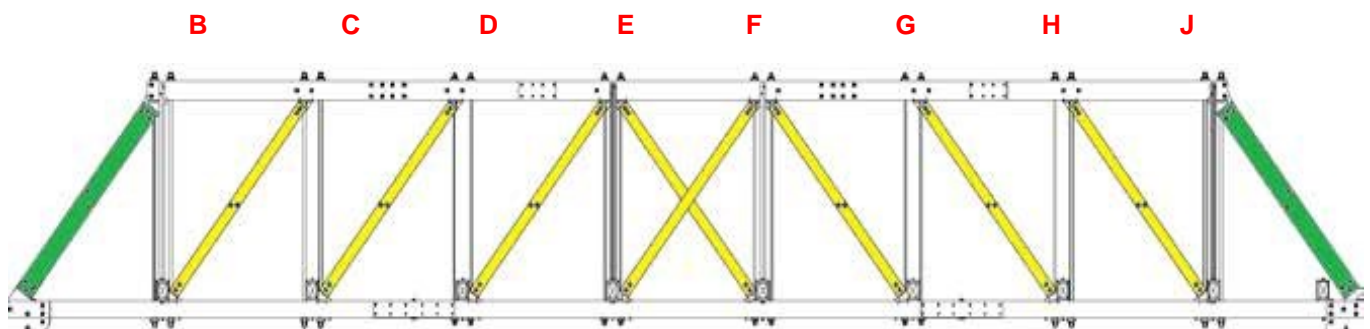

Source: author

Original Design

Principals and diagonals consist of two NSW hardwood timber flitches bowed around timber spacers to prevent warping and twisting. The original dimensions of the timber flitches in the principals were 14" x 6½" (356 x 165 mm) the same as the top chords. The original dimensions of the timber flitches in the diagonals were 8" x 4½" (202 x 114 mm) except for the central panel with its counterbracing which consisted of a single 8" x 8" (202 x 202 mm) and a double 8" x 4" (202 x 102 mm). The original drawings for the principals and diagonals (originally called braces) are in Figure 2.16.

Existing Condition

None of the timbers in the principals or diagonals are original fabric, but they are all NSW hardwood. According to the most recent inspection, the principals and diagonals are in variable condition as summarised in the table below. Problems reported with regard to principals and diagonals in the most recent inspection include weathering, cracked and split timber spacers, vertical splits along timber flitches and rot at the bases of flitches and at interfaces with spacers. Some minor crushing at the base of one of the flitches of a principal has also been reported.

This indicates that much of the timber has decayed, but the loss of strength is not of a sufficient magnitude to affect the serviceability of the bridge given the current five tonne load limit.

Photographs showing the condition of typical principals and diagonals are given in Figure 2.63.

Table 2-3: Summary of condition of principles and diagonals

Span	U/S or D/S	Member	Number of Elements in Condition State			
			1	2	3	4
1	Upstream	Principals	1	1	0	0
		Diagonals	2	6	0	0
	Downstream	Principals	0	2	0	0
		Diagonals	4	4	0	0
2	Upstream	Principals	0	2	0	0
		Diagonals	0	6	2	0
	Downstream	Principals	0	1	1	0
		Diagonals	4	4	0	0
3	Upstream	Principals	1	1	0	0
		Diagonals	1	6	1	0
	Downstream	Principals	1	1	0	0
		Diagonals	3	5	0	0

Analysis of Modifications

All of the principals and diagonals consist of paired timbers as per the original design. The only visible modification is that bolts have been added to the counterbracing at the centre of each span, whereas the original design and construction had no bolts at the centre where diagonals intersect.

Though the structural integrity of the principals and diagonals is considerably less than the original design due to deterioration, the heritage integrity is good, being very close to the original design.

Figure 2-63: Photographs of typical deterioration of principals and diagonals, 2017 inspection¹²⁹



¹²⁹ Richard Forrester, Manager Timber Inspections, Victoria Bridge termite inspection report 17 Feb 2017.

2.8.6 Tension rods

The tension rods of the Allan truss are highlighted in Figure 2.64 below. The 2" (50 mm) diameter tension rods are highlighted in green and the 1½" (38 mm) tension rods are highlighted in yellow.

Figure 2-64: Original 90' Allan truss design with tension rods highlighted

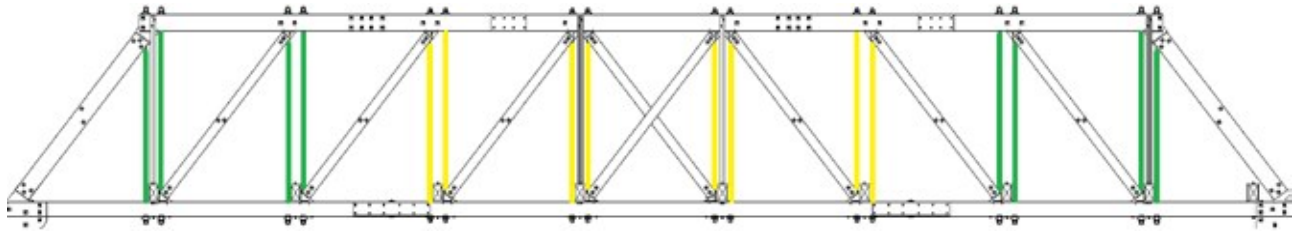

Source: author

Original Design

The tension rods are provided in matching pairs at each panel point, and placed either side of the cross girders, passing through the space between the top and bottom chord flitches with tapered wrought iron washer plates provided top and bottom to span the gap between the timber flitches.

Existing Condition

Some of the tension rods may be original fabric. According to the most recent inspection most of the tension rods are in condition state 1, although four are in condition state 2 and three are in condition state 3. Problems reported with regard to tension rods in the most recent inspection include minor surface corrosion, missing nuts, loose nuts and displacement of washers. This indicates that the tension rods are in good condition but require tightening and nut replacement.

The loss of nuts is particularly problematic on the Allan and McDonald trusses where the thin nut is installed before the main nut, so that if the main nut falls off, only the thin nut with very limited capacity remains. Bennett, de Burgh and Dare trusses therefore had the main nut first and the thin nut afterwards, the thin nut being only a precautionary measure to reduce the risk of nut loosening.

Figure 2.65 below shows the issue at Victoria Bridge. The photograph shows the bottom of a pair of tension rods under the bottom chord with the thin nut on top, fully threaded, but the main nut only half way connected to the tension rod, and therefore having only a fraction of the original capacity and also being at considerable risk of falling off as other nuts have been reported missing.

Figure 2-65: Photograph of thin nuts and main nuts only partially threaded



Source: author 2017

Analysis of Modifications

Most of the tension rods appear to be of original design and dimensions. Due to the top chord flashing, the detailing at the top of the tension rods is not visible for inspection. Also, due to the height of the bridge and difficulties in access below the bridge, the detailing at the bottom of the tension rods is also not visible for close inspection except for those near Abutment A.

However, it was noticed on site that one of the tension rods has been damaged and is bent out of shape (Figure 2.66), and also a minimum of four tension rods have been replaced with considerably larger tension rods (diameter approximately 10 mm greater than the original), one example of which can be seen in Figure 2.66 below. There are two examples of this on Span 1 and two on Span 3 both on the upstream side. The aesthetics of the unequally paired tension rods adversely impacts on the bridge as they detract considerably from the original design and are on the pedestrian walkway side, therefore more clearly visible for close inspection by the bridge users. The unequal diameter of tension rod is also a poor result structurally, since the larger tension rod will always attract considerably more load, thereby introducing eccentricities not in the original design. These modifications detract from the structural integrity and the heritage integrity.

Figure 2-66: Photograph of unequal (left) and damaged (right) tension rods



Source: author 2017

2.8.7 Cast iron shoes

Original Design

The cast iron shoes of the Allan truss are located at the top and bottom of each principal and diagonal. There are thirteen different types of cast iron shoes at Victoria Bridge.

Existing Condition

Some of the cast iron shoes are probably original fabric. According to the most recent inspection most of the cast iron shoes are in condition state 1, although five are in condition state 2, two are in condition state 3 and one is in condition state 4 (this refers to a broken bottom chord shoe in Span 3). Problems reported with regard to cast iron shoes in the most recent inspection include minor cracking, loss of coach screws or bolts, looseness in connections and gaps opening up. Overall, the cast iron shoes appear to be in fair condition but the looseness is a structural concern.

Figure 2-67: Photographs of various cast iron shoes at Victoria Bridge



Source: author 2013

Analysis of Modifications

The documentary evidence considered in Section 2.7 highlighted that a number of bottom chord shoes have broken in the past, and so it is likely that they have been replaced. Due to difficulties in access, it could not be determined if these have been replaced to the original design or not.

Photographs in Figure 2.67 show some cast iron shoes that are visible from the pedestrian footway, these being primarily the top chord shoes, with only small parts of the bottom chord shoes being visible from any public view. They are painted black as per the original colour scheme. The heritage integrity appears to be good, although information is lacking about replacement shoes. The structural integrity is poor due to looseness of connections and due to the susceptibility of these cast iron shoes to brittle fracture which has occurred on at least eight shoes so far.

2.8.8 Sway braces

The sway brace locations of the Allan trusses at Victoria Bridge are highlighted in Figure 2.68.

Figure 2-68: Original 90' Allan truss design with sway brace locations highlighted

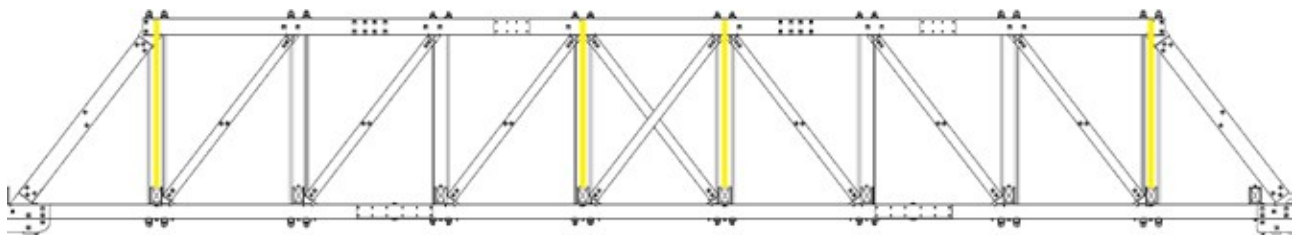

Source: author

Original Design

Sway braces consist of T Irons 4" x 2" x 3/8" (102 x 50 x 10 mm) bent at each end to be attached to the cross girders with two bolts and attached to the top chord with either bolts (for sway braces near the ends of spans) or with coach screws (for sway braces near the centre of spans).

Existing Condition

The sway braces at Victoria Bridge at Picton appear to be of the original design dimensions, and they are located in their original locations (ie. no additional sway braces have been added, and sway braces have not been lengthened as has been attempted on other bridge). The sway braces were not covered in the most recent inspection, but they appear to be in good condition.

Figure 2-69: Photographs of upstream sway braces at Victoria Bridge



Source: author 2017

Analysis of Modifications

It is possible that the sway braces are original fabric, but a higher level of deterioration would be expected for metal of that age, so they may have been replaced with new sway braces to the original design. It is known that the sway braces have been removed in the past (for example, see Figure 2.46 showing temporary replacement of straight sway braces with curved sway braces).

Figure 2-70: Photographs of typical condition sway braces



Source: author 2017

2.8.9 Cross girders

The cross girder locations of the Allan trusses at Victoria Bridge are highlighted in Figure 2.71 below. The short cross girders are highlighted in yellow, and long cross girders in green.

Figure 2-71: Original 90' Allan truss design with cross girders highlighted

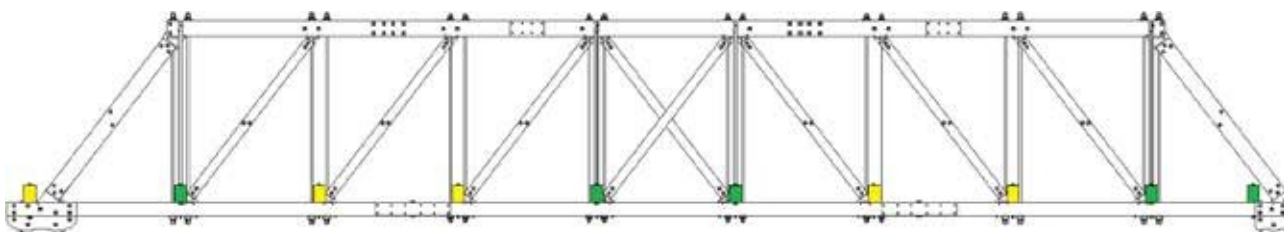

Source: author

Original Design

The two end cross girders of NSW hardwood timber (one at each abutment) are larger than all the other cross girders, being 15" x 12" x 20'8" long (380 x 304 x 6300 mm). This cross girder is shown highlighted in yellow on the far left hand side of Figure 2.71 above. All other cross girders are 15" x 10" (380 x 254 mm)

with short cross girders being 20'2" (6.15 m) long and long cross girders being 31'0" (9.45 m) long. The cross girder highlighted in green on the far right hand side of Figure 2.71 above was originally 24'11" (7.59 m) long extending only on the downstream side to support the pedestrian refuge.

Existing Condition

None of the timbers in any of the cross girders are original fabric, but they are all NSW hardwood. According to the most recent inspection, the cross girders are in variable condition as summarised in the table below. Problems reported with regard to cross girders in the most recent inspection include horizontal cracks and splits, excessive moisture, weathering and loose connections. This indicates that much of the timber has decayed, but the loss of strength is not of a sufficient magnitude to affect the serviceability of the bridge given the current five tonne load limit.

Span	Number of Cross Girders in Condition State			
	1	2	3	4
1	3	5	2	0
2	4	5	1	0
3	1	7	2	0

Analysis of Modifications

The cross girders have been considerably modified so that they currently reflect very little of the original design intent or the original aesthetic of the Allan trusses. The structural integrity of the cross girders is considerably less than the original design due to deterioration, and the heritage integrity is very poor, with a number of intrusive modifications as outlined below.

The original design had 13" (330 mm) spacing of tension rod pairs. This left a minimum 1/2" clear space each side of each cross girder at the larger tension rods, and 3/4" clear space each side of each cross girder at the smaller tension rods. Now, some of the tension rods have been replaced with larger tension rods and many of the cross girders have been replaced with wider cross girders which have been notched in a rather unsightly manner to accommodate the tension rods.

Figure 2-72: Unsightly notching of cross girders at tension rod locations



Source: author 2013

Figure 2-73: Early photo with cross girders, undated



Source: Wollondilly Heritage Centre and Museum

Figure 2-74: Photo showing existing non-original long cross girders



Source: author 2017

Not only have many cross girders been replaced with wider cross girders as can be seen in Figure 2.72, but also the shorter cross girders have been replaced with longer cross girders and painted white so that the view of the side of the bridge is considerably changed (compare Figures 2.73-74). The reasons for the longer cross girders include support of the maintenance monorail (Figure 2.75) as well as provision for external footways to be economically provided during maintenance works.

Figure 2-75: Maintenance monorail attached to underside of cross girders



Source: author 2013

Furthermore, some cross girders have been replaced with new cross girder deeper than the original cross girders, and so they have been notched over the bottom chords (Figure 2.76).

Figure 2-76: Unsightly notching of cross girders at bottom chord locations



Source: author 2013

2.8.10 Stringers and decking

The stringers and decking of the Allan trusses at Victoria Bridge are indicated in Figure 2.77.

Figure 2-77: Diagram showing original configuration of stringers and deck

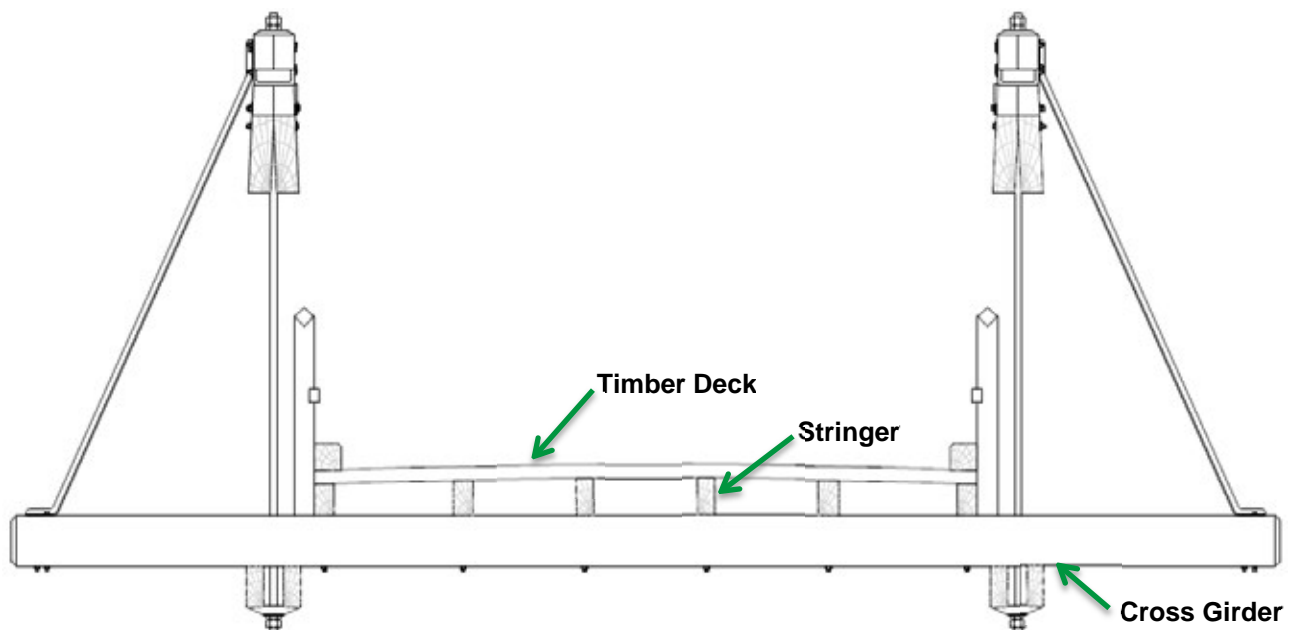

Source: author

Original Design

Although we do not have any original specifications for an Allan truss, we do have an original specification for a Dare truss, and photographic evidence indicates that similar specifications applied to all five types of timber truss bridges when it came to the treatment of the timber deck. Following are excerpts from an original specification for the construction a timber truss bridge:

*Timber employed to be.... Tallow-wood, white mahogany, grey gum, red gum, grey box, blackbutt, or brush box, at option of Contractor, for the planking... All to be of approved quality, sound, straight, free from sapwood, large or loose knots, waness, shakes, gumveins, cores, or other defects; to have clean sharp arrises, and to be of the full dimensions shown or specified... Sawn timber to be absolutely free from heart, and to be so fixed that the surface which was farthest from the heart of the tree will be the outermost in the work other than planking, and uppermost in the planking... The flooring planks, which laid, to receive on the upper surface between kerbs one coat, composed of 7 parts coal tar, 4 parts of Stockholm tar, and 1 part of pitch, thoroughly melted together, and applied hot; to be well sprinkled with a layer of clean sharp sand and lime.... All tarring to be completed before painting is commenced, and no tar is to be applied during or immediately after wet weather, or while surface of timber is wet.... Floor to consist of 4-in. sawn planking, from 6 in. to 10 in. wide, laid transversely, as shown. All planks to run the entire width of bridge in one length; to be laid flush and close, and secured to girders and stringers by $\frac{3}{8}$ -in. square spikes, 7 in. long, two spikes at each intersection; heads of spikes to be drifted down $\frac{1}{4}$ in., and surface of the floor left smooth, all inequalities being adzed down...*¹³⁰

¹³⁰ Dept. Public Works, NSW Harbours, Roads and Bridges Branch, Contract for construction of a composite truss bridge over Wakool River, at Gee-Gee Crossing, Swan Hill to Deniliquin Road, Specification, 1928.

The original stringers came in three different sizes, 6" x 9¼" (152 x 235 mm), 6" x 10¼" (152 x 260 mm) and 5" x 10¾" (127 x 273 mm). These different sizes were designed to support the curved deck to ensure good drainage. At the two end panels, two additional stringers were provided adjacent to the outer stringers with dimensions 6" x 9¾" (152 x 248 mm) to support the wrought iron frame which in turn supported the cast iron scuppers located at the four corners of each span.

Existing Condition

None of the timbers of the stringers or decking are original fabric, but they are all NSW hardwood. According to the most recent inspection all of the stringers are in condition state 1. Most of the transverse decking is in condition state 1, but there are two in condition state 4 due to severe rot. Longitudinal sheeting has been added and is all in condition state 2 due to loss of wearing surface, loose deck bolts and cracked and split ends of some sheeting timbers. This indicates that most of the stringer and decking timbers are in good condition, having been fairly recently installed.

Analysis of Modifications

The stringers and especially the decking have been considerably modified so that they currently reflect very little of the original design intent or the original aesthetic of the Allan trusses. The heritage integrity is very poor, with a number of intrusive modifications as outlined below. While the stringers (which can be seen in Figure 2.78 below) still consist of six rows of sawn timbers, the original sizes have been lost along with the cambered deck Allan took such care to provide.

Figure 2-78: Photo of existing stringers and spaced transverse decking



Source: author 2017

Figure 2-79: Bolted and spaced decking



Source: author 2017

Originally the deck was tightly spaced (allowing no light through) and completely smooth with a 38 mm camber for drainage and a black tar surface on top. The iron spikes which connected the decking to the stringers and cross girders were hammered flush with the top of the timber and were covered with the tar thereby making them effectively invisible. Currently the decking is spaced, allowing some light (and much water) through the deck, and a large number of bolts have been added, as can be seen in Figure 2.79. The current decking competes somewhat with the aesthetic of the trusses with the strong longitudinal lines of the sheeting and the irregular spacing of the protruding bolt heads and joints in the sheeting when viewed from above.

Figure 2-80: Photo of existing longitudinal sheeting viewed from above



Source: author 2013

2.8.11 Railing

Original Design

The original timber railing was a traditional timber ordnance fence which was typical of the railings on Allan, de Burgh and Dare truss bridges. Timber posts were 6" x 4" (152 x 102 mm) and were bolted to the outer stringers and to the kerbs. The posts were located at cross girder locations. The railing was 4'0" (1.22 m) high from the top of the deck, and located immediately behind the 8" x 8" (204 x 204 mm) timber kerb. The rails consisted of a 4" x 4" (102 x 102 mm) timber top rail placed at a 45 degree angle, and a 4" x 3" (102 x 76 mm) timber mid rail 2'0" (0.61 m) above the deck. While some Allan trusses also had either one or two lengths of 8 gauge (3 mm) wire threaded through holes in the timber posts, these were not specified for Victoria Bridge. However, two lengths of wire have been installed, and from the photographic record it is clear that this addition was made very early in the life of the bridge, if not during the initial construction.

The original timber railing had no real structural capacity and was not intended to be a traffic barrier for vehicles, but was intended to delineate the sides of the bridge for vehicles and to prevent horses, bullocks, sheep and cows (who were the most frequent bridge users) from falling off the bridge. When Victoria Bridge first opened in 1897, the automobile had only recently been invented.

Existing Condition

None of the timbers of the railing are original fabric. According to the most recent inspection, some sections of the railings are undersize and rotten or split and some require repainting and reflectors.

Analysis of Modifications

The existing timber kerbs and rails reflect something of the original form, containing white timber posts and rails, although the original black metal fixings are now painted white (see Figure 2.80). The kerb has been raised in level so that it sits above the longitudinal sheeting rather than directly on the transverse decking, thereby modifying the geometry of the fence in relation to the truss.

As can be seen in Figure 2.81, by far the most considerable modification to the railings is the addition of a modern steel guardrail along the length of the bridge to provide a safe passage for pedestrians. The guardrail consists of two W-beams attached to metal posts. This is a non-original feature which detracts from the aesthetics of the bridge. Furthermore, since the guardrail is a flexible barrier system, it has very limited ability to redirect an errant vehicle, and so its function is more delineation than protection of pedestrians.

Figure 2-81: Guardrail



Source: author 2013

2.8.12 Piers

Figure 2-82: Diagram showing original design details for timber trestle piers

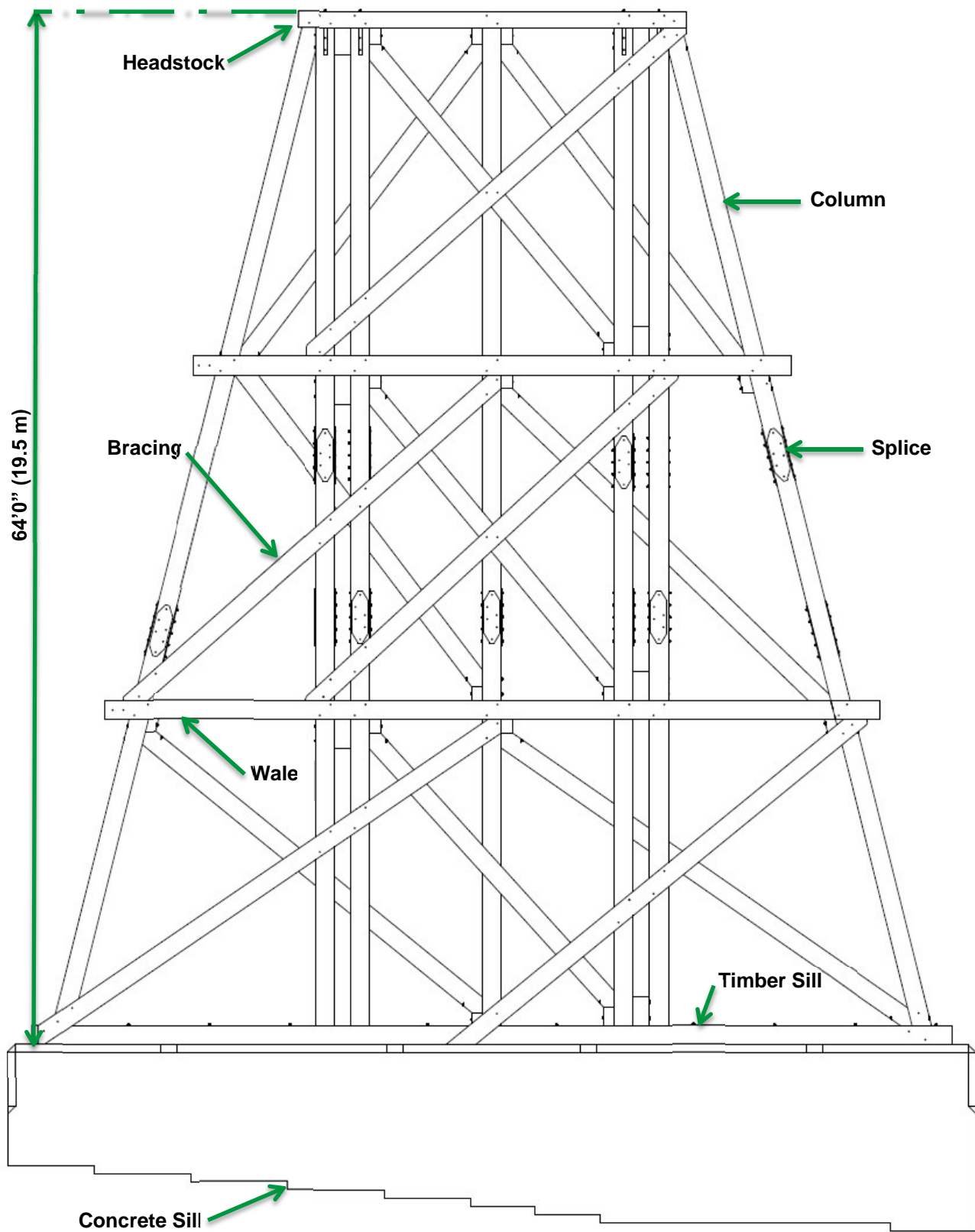

Source: author

Original Design

The two piers consist of identical 64'0" (19.5 m) high double timber trestle piers on concrete sill beams. The timber columns consist of timbers 14" x 14" (356 x 356 mm) and the bracing members are either 14" x 14" (356 x 356 mm) or 14" x 7" (356 x 178 mm) single or double members. The wales are 14" x 7" (356 x 178 mm) and the headstocks are 12" x 6" (304 x 152 mm) timbers.

Existing Condition

None of the timbers of the piers are original fabric but the concrete base is original.

According to the most recent inspection, there is considerable variability in the condition of the various timber elements, as summarised in the table below. Problems reported with regard to timbers in the piers include deformation, rot, splits and cracks, termite activity and weathering.

Table 2-4: Variability in the condition of timber elements

Span	Number of Cross Girders in Condition State			
	1	2	3	4
Pier 1 sill beams	2	0	0	0
Pier 1 columns	5	5	2	0
Pier 1 headstocks	2	0	0	0
Pier 1 braces	10	12	0	0
Pier 1 wales	2	0	0	2
Pier 2 sill beams	1	1	0	0
Pier 2 columns	3	8	0	1
Pier 2 headstocks	2	0	0	0
Pier 2 braces	7	12	3	0
Pier 2 wales	0	4	0	0

The concrete bases are also in variable condition with evidence of cracking at some locations.

Figure 2-83: Photographs of condition of concrete bases at piers



Source: Roads and Maritime

Although not currently directly impacting upon the condition of the bridge fabric, another issue is the scour of the creek bed which occurred during a flood in 2016. The ground level has dropped by up to two metres at some locations, and the steepness of the banks has increased very close to the piers. The extent of the 2016 scour is shown in Figures 2.84 and 2.85. If further scour such as this were to occur the piers might be undermined.

Given that the concrete bases are unreinforced and in variable condition, any undermining of the concrete in a scour event could cause collapse of the bridge. Another considerable risk at this bridge due to the steep river banks is that boulders may become loose and roll down the banks crashing into the bases of the timber piers and dislodging them. This could conceivably be triggered by an earthquake event (there was, for example, an earthquake at Picton in 1973 measuring 5.6 on the Richter scale) or by heavy rains.

Figure 2-84: Diagram indicating extent of scour from 2016 flood

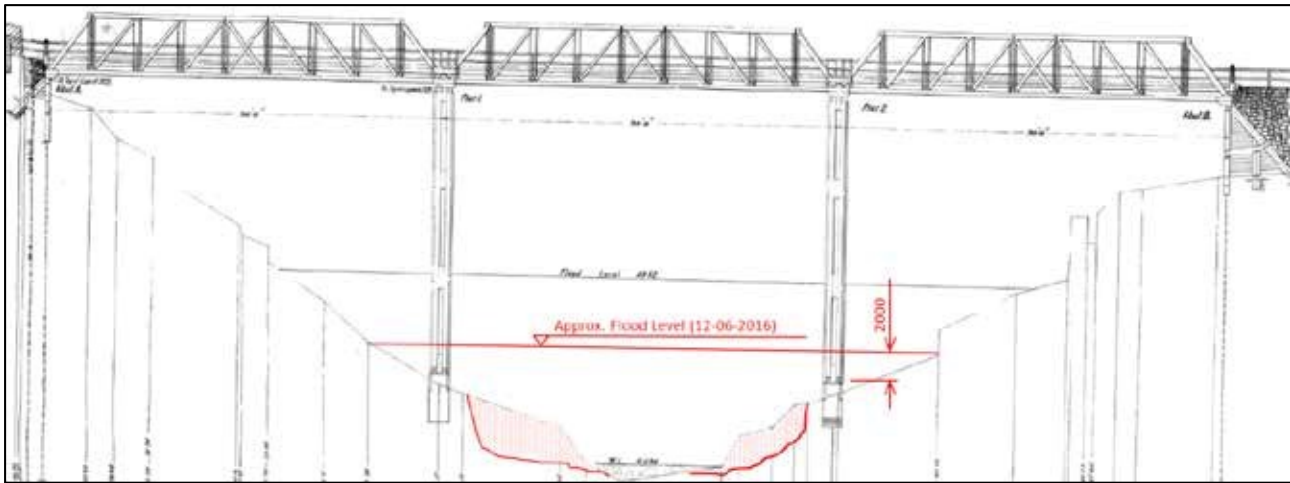

Source: Roads and Maritime

Figure 2-85: Steep embankment due to scour



Source: Roads and Maritime

Analysis of Modifications

The two piers appear to be largely original in configuration, although a number of additional splices have been added (due to difficulties in obtaining timber) and spacer blocks modified. Galvanised welded metal brackets have been added at the base of each pier rather than mortise and tenon joints. These modifications detract from the structural integrity and heritage integrity of the bridge.

Figure 2-86: Timber double trestle piers at Victoria Bridge



Source: Amie Nicholas 2013

2.8.13 Abutments

Figure 2-87: Diagram showing original design details for timber abutments

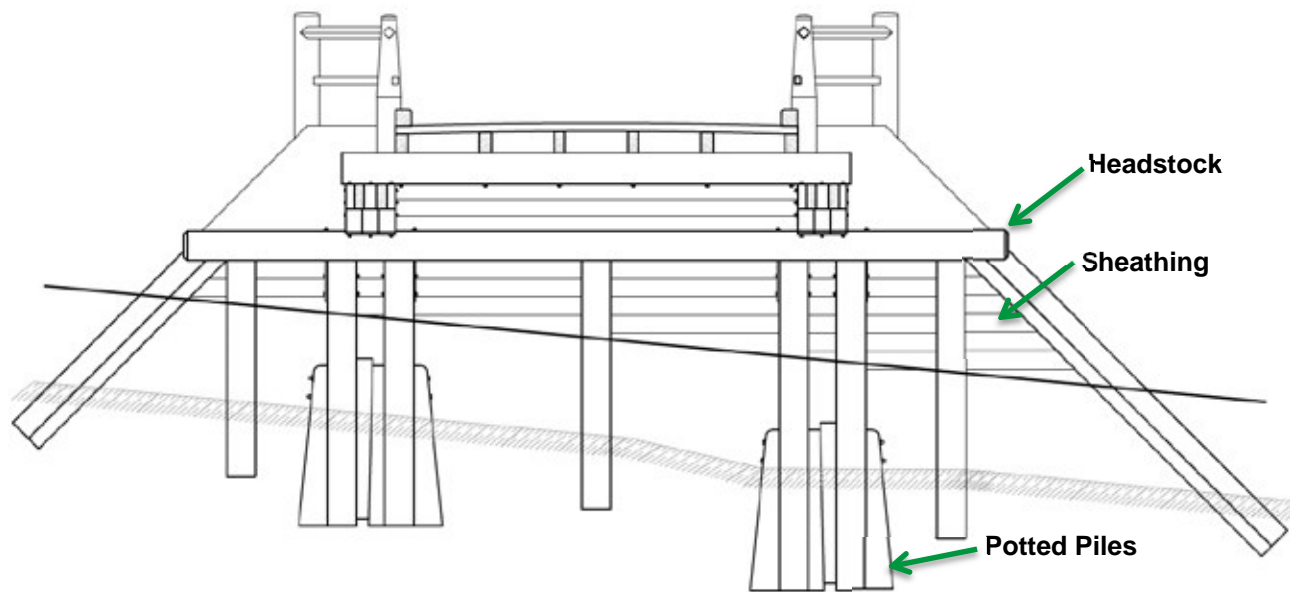

Source: author

Original Design

The two abutments originally consisted of timber potted piles 14" x 14" (356 x 356 mm) and a timber headstock also 14" x 14" (356 x 356 mm) with 4" (102 mm) timber sheathing behind the piles.

Existing Condition

None of the fabric in the abutments is original.

According to the most recent inspection, Abutment A (which is being temporarily supported with various props) is almost entirely in condition state 4, indicating considerable structural risk and Abutment B is in condition state 1, having been replaced in 2007 with an entirely new abutment. Photographs of the condition and temporary propping of Abutment A are on the following page.

The embankment for the road approach behind Abutment B (outside of the curtilage of the bridge, and also outside of Roads and Maritime control) is showing signs of risk of failure.

Analysis of Modifications

Both abutments have been considerably modified so that they currently reflect very little of the original design. The structural capacity has been compromised and the heritage integrity is poor.

As noted in Section 2.7, Abutment B was not reconstructed to the original design in 2007. Rather than building the embankment with rock fill as per the original design, a modern product called geofoam was used. The new abutment is also considerably different from the original in that the new abutment does not have potted piles, but is rather bolted with steel brackets to a new concrete foundation which was constructed to support the new timber abutment. This was designed to provide a somewhat similar aesthetic to the original abutment, but structurally it exhibits a completely different behaviour, considerably lacking in longitudinal rigidity.

Abutment A is a much less visible and accessible abutment, being considerably shorter than Abutment B, and also being located in a cutting, rather than an embankment, so it is rather hidden. Modifications to Abutment A include addition of concrete at the bases of some piles and also under some temporary props. There are also fabricated steel props as well as piles of timber packing and sand bags. Due to deterioration and various modifications, the ends of the bottom chord on the upstream side is currently somewhat buried in sediment and therefore at risk of deterioration.

Figure 2-88: Photograph of Victoria Bridge Abutment A downstream side



Source: author 2017

Figure 2-89: Victoria Bridge Abutment A upstream side



Source: Amie Nicholas 2017

2.9 Summary of physical condition and heritage integrity

The bridge as a whole is in fair condition and with relatively good heritage integrity. It demonstrates most aspects of the original design at the general as well as the detailed level. The bridge retains most of the distinguishing features of the Allan design as outlined in Section 2.4.3.

The fact that the bridge has a five tonne load limit means that it cannot demonstrate the strength of the original design or the strength of the original NSW hardwoods with which it was constructed.

Table 2-5: Summary of element condition and integrity

Elements	Condition	Integrity (ie: ability to demonstrate original design)
Top Chords	Poor	Fair: Timber is not original fabric, additional splices introduced, still recognisable as an early Allan truss.
Bottom Chords	Good	Fair: Timber is not original fabric, splice locations not original, symmetry of design has been lost about both the longitudinal and the transverse axes, still recognisable as standard Allan truss bottom chords.

Principals and Diagonals	Variable	Good: Timber is not original fabric, some minor modifications to bolting arrangement, but sizes and configurations largely as original and still recognisable as standard Allan truss principals and diagonals.
Tension Rods	Good	Variable: Probably contains some original fabric, but some new tension rods have been introduced with nonoriginal dimensions which are visually intrusive.
Cast Iron Shoes	Variable	Variable: Probably contains some original fabric, but some have probably been replaced and it is not known whether the replacements match the original design.
Sway Braces	Good	Good: Possibly original fabric, no visible modifications.
Cross Girders	Variable	Poor: Timber is not original fabric, cross sectional dimensions not original, lengths not original, connection detailing at interfaces not original, notching introduced in a visually intrusive manner, extended cross girders detract from the technical significance of the Allan truss which minimised weights and lengths of timber.
Stringers and Decking	Good	Poor: Timber is not original fabric, stringers are not original dimensions, end stringers supporting scuppers are missing, scuppers are missing, decking does not reflect the original detailing or aesthetic or function and does not demonstrate the original design intent. There are intrusive additions when viewed from any angle.
Railing	Poor	Variable: Timber is not original fabric. General form of posts and rails is similar to original though the colour scheme of the metal fixings is not original. The introduction of a metal guardrail along the length of the bridge detracts from the significance of the bridge and does not reflect the original design intent of the Allan truss, which was to provide external footways.
Piers	Variable	Fair: Timber is not original fabric, additional splices introduced not immediately discernible as new work, some modifications to elements and connections.
Abutments	Variable	Poor: No original fabric, Abutment B reconstructed to new design, Abutment A modified and propped.
Visual context and Setting	Variable	Poor: Height restriction portals at either end of the bridge block views, signage, powerlines and guardrails detract somewhat from the visual amenity, and the overgrown vegetation and flying fox population make early views of the bridge no longer available today.

3. Analysis of significance

3.1 Existing statement of significance

The NSW SHR statement of heritage significance for Victoria Bridge at Picton currently reads,

Completed in 1897, the Victoria Bridge is an early example of an Allan type timber truss road bridge, and in 1998 was in fair condition. As a timber truss road bridge, it has many associational links with important historical events, trends, and people, including the expansion of the road network and economic activity throughout NSW, and Percy Allan, the designer of this type of truss. Allan trusses were third in the five-stage design evolution of NSW timber truss bridges, and were a major improvement over the McDonald trusses which preceded them. Allan trusses were 20% cheaper to build than Mc Donald trusses, could carry 50% more load, and were easier to maintain. Having the tallest timber trestle supporting piers of any timber truss bridge, the Victoria Bridge has an imposing appearance, and is both technically and aesthetically significant as a result. In 1998 there were 38 surviving Allan trusses in NSW of the 105 built, and 82 timber truss road bridges survive from the over 400 built. The Victoria Bridge is a representative example of Allan timber truss road bridges, and is assessed as being State significant, primarily on the basis of its technical and historical significance (last updated on 15 June 2005).¹³¹

Considering the major changes that have taken place across the timber truss bridge population since then and new historical evidence as a result of further research, it is necessary to reassess whether this statement continues to adequately reflect the heritage significance of the bridge.

3.2 Comparative analysis

Of over 100 Allan type timber truss bridges built, twenty remain in 2018. These are listed in the table below and include sixteen in the care of RMS and four owned by others with one in the ACT.

Table 3-1: Remaining Allan Truss bridges in NSW

Bridge	Year	Spans	Listings		
			SHR	S170	LEP
Beryl Bridge over Wyaldra Creek near Gulgong	1927	2-70'	No	Yes	No
Tooleybuc Bridge over the Murray River	1925	2-70'	Yes	Yes	No
Carrathool Bridge over the Murrumbidgee River	1922	2 70'	Yes	Yes	No
Bridge over the Abercrombie River near Tuena	1919	2-70'+90'	No	Yes	No
Victoria Bridge over Stonequarry Creek at Picton	1897	3-90'	Yes	Yes	No
Wallaby Rocks over the Turon River near Sofala	1897	3-90'	Yes	Yes	No

¹³¹ SHR listing for Victoria Bridge over Stonequarry Creek from Heritage Division website (accessed 10/08/17): <http://www.environment.nsw.gov.au/heritageapp/ViewHeritageItemDetails.aspx?ID=5051388> ¹⁶² *NSW Heritage Manual*, NSW Heritage Office, 2001.

Hinton Bridge over the Paterson River	1901	2-90'	Yes	Yes	Yes
Vacy Bridge over the Paterson River	1898	2-90'	Yes	Yes	Yes
Barrington Bridge over the Barrington River	1918	2-90'	No	Yes	Yes
Swan Hill Bridge over the Murray River	1896	2-90'	Yes	Yes	No
Payten's Bridge, Collett's Crossing, Lachlan River	1926	2-90'	No	Yes	No
Charleyong Bridge over Mongarlowe River	1901	1-90'	No	Yes	No
Bridge over the Goodradigbee River at Wee Jasper	1896	1-90'	Yes	Yes	No
Rossi Bridge over the Wollondilly River near Goulburn	1898	3-90'	Yes	Yes	Yes
Morpeth Bridge over the Hunter River	1898	3-110'	Yes	Yes	Yes
Dunmore Bridge over the Paterson River at Woodville	1899	3-110'	Yes	Yes	Yes
*Pyrmont Bridge over Darling Harbour	1902	12-82'	Yes	Yes	No
*Bridge over Styx River near Jeogla	1900	1-90'	No	N/A	No
*Bridge over Molonglo River near Foxlow	1897	1-90'	No	N/A	No
*Tharwa Bridge over the Murrumbidgee River, ACT	1895	4-90'	N/A	N/A	N/A

** indicates bridge not owned or managed by Roads and Maritime Services*

Tharwa Bridge is the only example remaining of an Allan truss that originally had no sway bracing but had "wind stays" instead, and it continued to operate with only wind stays for approximately 70 years. Unfortunately, standard sway bracing has since been added so there is no remaining example of an Allan truss with "wind stays" and nothing to distinguish Tharwa as particularly early.

The other distinguishing mark of early Allan truss bridges is the top chord splice details. Bridges constructed prior to 1898 had the top chord splice detailing of Victoria Bridge at Picton, consisting of staggered flat metal plates. Bridges constructed in 1898 onwards had longer top chord timbers and only a single central splice with pairs of rounded metal angles provided each side of the splice.

Examples remaining of Allan truss bridges constructed with early top chord splice details include only Tharwa (1895), Swan Hill and Wee Jasper (1896), Wallaby Rocks, Foxlow and Picton (1897). Of these early bridges, the splicing details have been completely modified at Tharwa (channel sections, locations changed) and Wee Jasper (replaced with later standard detail of paired angles), substantially modified at Wallaby Rocks (channel sections but at original locations), slightly modified at Swan Hill (still steel plates, but longer plates with more bolts), and remain original in detailing only at Foxlow and Picton (though one of the spans at Picton has been modified).

3.3 Assessment of significance

3.3.1 Criterion A – Historical

An item is important in the course, or pattern, of NSW’s cultural or natural history.

Guidelines for INCLUSION

- shows evidence of a significant human activity
- is associated with a significant activity or historical phase
- maintains or shows the continuity of a historical process or activity

Guidelines for EXCLUSION

- has incidental or unsubstantiated connections with historically important activities or processes
- provides evidence of activities or processes that are of dubious historical importance
- has been so altered that it can no longer provide evidence of a particular association

Victoria Bridge is an early example of an Allan type timber truss road bridge.

The Allan truss is historically significant as the third of five stages of timber truss road bridge design in New South Wales. The trusses took advantage of the high quality New South Wales hardwoods, known to be among the strongest and most durable in the world. The design is an example of innovative and efficient timber engineering in a time when budgets were tight and so expensive imported construction materials were to be avoided. The evolution in design shows the growing knowledge of timber as a structural material, the increasing difficulty in obtaining large section long timbers, and the need for durable and maintainable bridge designs. The bridge is therefore able to demonstrate the State historical theme of “Technology”.

Victoria Bridge provided an essential link for safe and reliable transport, particularly to the train station, both for locals on foot and for traffic from the Main Southern Road and other towns such as Bargo. Also of importance was the need to increased road safety by reducing the amount of traffic passing over the dangerous level railway crossing. It is historically significant through its association with the expansion of the New South Wales road network, and the contribution of that road system to settlement, development and economic activity throughout New South Wales. The bridge is therefore able to demonstrate the State historical theme of “Transport”.

Victoria Bridge therefore meets this criterion at a **State** level.

3.3.2 Criterion B – Associative

An item has strong or special association with the life or works of a person, or group of persons, of importance in NSW's cultural or natural history.

Guidelines for INCLUSION

- shows evidence of a significant human occupation
- is associated with a significant event, person, or group of persons

Guidelines for EXCLUSION

- has incidental or unsubstantiated connections with historically important people or events
- provides evidence of people or events that are of dubious historical importance
- has been so altered that it can no longer provide evidence of a particular association

As an Allan truss, Victoria Bridge has strong associations with Percy Allan, Chief Draftsman when he designed this truss. Allan was an eminent engineer, employed by the Department of Public Works for almost fifty years, during which time he designed over six hundred bridges. He became Chief Engineer, National and Local Government Works, and made considerable contributions to various engineering institutions both in Australia and overseas, being awarded a Telford Premium for one of his papers.

Victoria Bridge therefore meets this criterion at a **State** level.

3.3.3 Criterion C – Aesthetic / Technical

An item is important in demonstrating aesthetic characteristics and/or a high degree of creative or technical achievement in NSW.

Guidelines for INCLUSION

- shows or is associated with, creative or technical innovation or achievement
- is the inspiration for a creative or technical innovation or achievement
- is aesthetically distinctive
- has landmark qualities
- exemplifies a particular taste, style or technology

Guidelines for EXCLUSION

- is not a major work by an important designer or artist
- has lost its design or technical integrity
- its positive visual or sensory appeal or landmark and scenic qualities have been more than temporarily degraded
- has only a loose association with a creative or technical achievement

Victoria Bridge is a picturesque contribution to the township of Picton. A remarkable feature in this bridge is the great height, the deck of the bridge being 92' (28.0 m) above the creek. The piers supporting the

trusses are 64' (19.5 m) high and are the tallest timber trestle piers of any timber truss bridge in New South Wales. The bridge fits neatly into the landscape, being aesthetically pleasing in scale, proportion and materials used. As a timber truss bridge with its original black and white colour scheme, the trusses are aesthetically distinctive and have landmark qualities.

The bridge exhibits the technical excellence of its design, as many of the structural details which distinguish it as an early Allan truss design are clearly visible, considerably assisted by the designated pedestrian access which has been provided along the length of the structure. Simply by walking over the bridge, excellent views can be obtained of almost all of the structural design details (general truss geometry, bowed and paired top chords, principals and diagonals, metal tension rods, cast iron shoe connections etc.), which would otherwise be almost impossible to appreciate on a bridge of this scale given the very limited views from off the bridge.

The design of this truss type was the inspiration for further technical innovation. The fact that it is an early Allan truss means that it is able to demonstrate the early top chord details as distinguished from the details which became standard in the following year after construction of Victoria Bridge. The bottom chord splice details were a technical achievement used in railway bridges as well as in bridges in the United States, where they had to be modified to suit the American timbers. The early failures, however, of the timber bottom chords in Allan trusses lead to the need for further technical innovation in the design of the following two timber truss types with metal bottom chords.

The aesthetic significance is somewhat diminished by the fact that the views to the bridge are increasingly obstructed by residences, vegetation, height restriction portals and a proliferation of flying foxes, meaning that the bridge can only really be properly viewed while crossing it.

The technical significance is also somewhat diminished by the fact that modifications have been made to the top chord splices (unique to early Allan truss bridges) and to cross girder lengths (which substantially detracts from the structural efficiency which is a distinguishing feature of the Allan truss).

However, Victoria Bridge still meets this criterion at a **State** level.

3.3.4 Criterion D – Social

An item has strong or special association with a particular community or cultural group in NSW for social, cultural or spiritual reasons.

Guidelines for INCLUSION

- is important for its associations with an identifiable group
- is important to a community's sense of place

Guidelines for EXCLUSION

- is only important to the community for amenity reasons
- is retained only in preference to a proposed alternative

Victoria Bridge is of substantial importance to the local and regional community, being highly esteemed for its historical value and its contribution to the town's sense of identity as a historical town. However, Victoria Bridge is also of substantial importance for its amenity, providing a vital link for pedestrians, and an important bypass to reduce congestion in the main part of town.

Due to its proximity to Sydney, Victoria Bridge at Picton is one of the more accessible timber truss bridges, and was listed by the National Trust in 1984.

Victoria Bridge therefore meets this criterion at a **State** level.

3.3.5 Criterion E – Scientific / Archaeological

An item has potential to yield information that will contribute to an understanding of NSW's cultural or natural history.

Guidelines for INCLUSION

- has the potential to yield new or further substantial scientific and/or archaeological information
- is an important benchmark or reference site or type
- provides evidence of past human cultures that is unavailable elsewhere

Guidelines for EXCLUSION

- the knowledge gained would be irrelevant to research on science, human history or culture
- has little archaeological or research potential
- only contains information that is readily available from other resources or archaeological sites

Victoria Bridge contains some metal elements which are probably original fabric, including cast iron shoes and wrought iron tension rods. These provide a future opportunity for materials testing and analysis to yield further information about the properties of iron used in bridges in the late 1800s.

However, the information gained by this analysis would not be substantial, and would also be available elsewhere. There is no known archaeological potential in the vicinity of the bridge.

Victoria Bridge therefore does not meet this criterion.

3.3.6 Criterion F – Rarity

An item possesses uncommon, rare or endangered aspects of NSW's cultural or natural history.

Guidelines for INCLUSION

- provides evidence of a defunct custom, way of life or process
- demonstrates a process, custom or other human activity that is in danger of being lost
- shows unusually accurate evidence of a significant human activity
- is the only example of its type
- demonstrates designs or techniques of exceptional interest
- shows rare evidence of a significant human activity important to a community

Guidelines for EXCLUSION

- is not rare
- is numerous but under threat

Victoria Bridge is rare as one of only six remaining early Allan truss bridges constructed with the early form of top chord splice detailing (and as one of only two that retain this particular detail, at least in part) and as one of only twenty remaining Allan truss bridges of approximately 100 built.

Victoria Bridge therefore meets this criterion at a **State** level.

3.3.7 Criterion G – Representativeness

An item is important in demonstrating the principal characteristics of a class of NSW's cultural or natural places; or cultural or natural environments.

Guidelines for INCLUSION

- is a fine example of its type
- has the principal characteristics of an important class or group of items
- has attributes typical of a particular way of life, philosophy, custom, significant process, design, technique or activity
- is a significant variation to a class of items
- is part of a group which collectively illustrates a representative type
- is outstanding because of its setting, condition or size
- is outstanding because of its integrity or the esteem in which it is held

Guidelines for EXCLUSION

- is a poor example of its type
- does not include or has lost the range of characteristics of a type
- does not represent well the characteristics that make up a significant variation of a type.

Victoria Bridge is representative at the State level as a fine example of an Allan truss bridge, including all of the principal characteristics of the early 90' Allan truss design and outstanding due to the esteem in which it is held, particularly by the local community, and also due to its integrity to the original design as an early Allan truss. The other outstanding feature of Victoria Bridge is the very tall timber trestle piers on which the trusses are supported, the tallest piers of their type in New South Wales. The bridge displays the original colour scheme and largely performs the function for which it was originally designed, which was to carry traffic and pedestrians.

Victoria Bridge therefore meets this criterion at a **State** level.

3.4 Revised statement of significance

Victoria Bridge at Picton is of State significance as an early example of an Allan truss road bridge. As a timber truss road bridge, it has strong associations with the expansion of the road network and economic

activity throughout New South Wales, and with Percy Allan, then Chief Draftsman, an eminent engineer, and the designer of this truss type. Allan became Chief Engineer, National and Local Government Works, and made considerable contributions to various engineering institutions both in Australia and overseas, being awarded a Telford Premium for one of his papers.

Allan trusses were the third in the five-stage development of New South Wales timber truss road bridges. The trusses took advantage of the high quality NSW hardwoods, known to be among the strongest and most durable in the world. The design is an example of innovative and efficient timber engineering in a time when budgets were tight. The evolution in design shows the growing knowledge of timber as a structural material, the increasing difficulty in obtaining long timbers of large cross-section, and the need for durable and maintainable bridge designs.

The bridge exhibits the technical excellence of its design, as the structural details which distinguish it as an Allan truss are clearly visible, considerably assisted by the designated pedestrian access which has been provided along the length of the bridge from which excellent views can be obtained of almost all of the structural design details, which would otherwise be almost impossible to appreciate on a bridge of this scale given the very limited views from off the bridge.

Victoria Bridge is representative at the State level as a fine example of an Allan truss bridge, including all of the principal characteristics of the early 90' Allan truss design and outstanding due to the esteem in which it is held, particularly by the local community, and also due to its integrity to the original design as an early Allan truss. The other outstanding feature of Victoria Bridge is the very tall timber trestle piers on which the trusses are supported, the tallest piers of their type in New South Wales. The bridge displays the original colour scheme and largely performs the function for which it was originally designed, which was to carry traffic and pedestrians.

3.5 Grading of significant components

The Overarching CMP sets out the methodology and approach taken here to grading of significant components.

The table below provides a summary of the grading of significant components

Table 3-2: Summary of the grading of significant components

Elements	Significance	Summary of justification for significance
Top Chords	Exceptional (State)	Although the top chords do not contain original timber fabric, are deteriorated, and have been modified, the original design can still be understood and differentiated from later Allan trusses.
Bottom Chords	High (State)	Alterations detract from aesthetics and only partially reflect the original design intent and original strength and robustness.
Principals and Diagonals	High (State)	Deterioration detracts from aesthetics and load limit means these elements can only partially reflect the original strength.
Tension Rods	Moderate (State)	Some original fabric, but new tension rods with non-original dimensions are visually intrusive and detract from significance.
Cast Iron Shoes	Moderate (State)	Some original fabric, but many cast iron shoes have broken and existing broken elements detract from strength and significance.

Sway Braces	Moderate (State)	Possibly original fabric with no visible modifications, but very common and of secondary importance, unwanted by Allan.
Cross Girders	Intrusive	Details common, and do not directly contribute to significance, modifications to these elements are so substantial that these elements are now damaging to the item's heritage significance. Extended cross girders detract from the technical significance of the Allan truss which minimised weights and lengths of timber.
Stringers and Decking	Intrusive	Modifications to these elements are so substantial that these elements are now damaging to the item's heritage significance, causing safety concerns and undermining interpretation, they do not reflect the original design intent or the original aesthetic.
Railing	Timber railings	Little Details of timber rails very common, and do not directly contribute to significance, details have been altered.
	Metal guardrail	Intrusive Addition of metal guardrail for the pedestrian walkway is damaging to the heritage significance of the item as it is visually intrusive and does not reflect the original design intent of the Allan truss, which was to allow provision of external footways.
Piers	High (State)	Although the piers do not contain original timber fabric, are deteriorated, have been modified and views are limited, the original size which is of high significance has been retained.
Abutments	Little	Details very common, and do not directly contribute to significance, have been substantially altered and weakened.
Visual context and Setting	Moderate (State)	The visual setting and context has been modified over the decades, but still contributes to overall significance.

4. Constraints and opportunities

As operational infrastructure, the timber truss bridges function as part of the State's road network. Roads and Maritime must ensure that Victoria Bridge is able to function appropriately. The bridge must also comply with statutory heritage constraints. In order to formulate appropriate conservation policies for the bridge and its environs, the requirements that will have an impact upon the future management of the bridge have been investigated and are summarised below.

4.1 Constraints and opportunities arising from the statement of significance

The following statements reflect how the state significance of the bridge directs what measures to conserve both tangible and intangible aspects of its heritage significance may be required. These should be considered in planning the future management of the bridge, as well as development of conservation policies.

The historical context of this bridge is the availability of high quality New South Wales hardwood timber. The significance of the Allan truss, and the place of Allan trusses within the evolution of the form is so closely related to the New South Wales hardwoods, these being the very reason for the design and vast use of this form of construction, that its conservation should prioritise the continued use of these hardwood timbers. The size of the trusses and timber piers at Victoria Bridge exemplify the strength and durability of NSW hardwoods.

Timber truss bridges have strong associations with the expansion of the road network and economic activity throughout NSW so the conservation of this bridge should retain its use as a vital part of the NSW road infrastructure. Victoria Bridge also has associations with provision of safe and reliable transport and as such, road and pedestrian safety should continue to be a priority in the conservation of Victoria Bridge.

As an Allan truss, Victoria Bridge has strong associations with Percy Allan and has the opportunity to demonstrate the engineered design details of one of Australia's eminent engineers of the past. Although the bridge as a whole is in variable physical condition and has been modified in some details, there remains sufficient evidence of the original design in the original drawings of the 90' Allan trusses and early photographs to allow restoration and reconstruction within the bounds of Articles 19 and 20 of the *Burra Charter*. The conservation of this bridge should seek to apply engineering excellence in a way that respects and highlights the work of one of Australia's eminent engineers.

As a timber truss bridge with its original black and white colour scheme and with the remarkably tall timber trestle piers in the steep valley of Stonequarry Creek, Victoria Bridge is aesthetically distinctive and has landmark qualities. There may be opportunities to improve the views of the bridge by regular removal of excessive vegetation growth in the area as well as removal or relocation of the height restriction portals which are currently situated at each end of the bridge. There may also be opportunities to improve the views by provision and maintenance of designated viewing locations with interpretive information to assist in the understanding of the bridge. Although the bridge is aesthetically striking, it is the innovative, economical, durable and maintainable engineering design which is particularly significant in Allan truss bridges. Therefore, the conservation of Victoria Bridge at Picton should not obscure the original engineering details, particularly those details which display innovations in durability and maintainability of the bridge.

While the pedestrian access along the length of the bridge allows appreciation of many of these technical details, the detailing of the existing pedestrian access detracts from both the aesthetic and the technical significance of the bridge. The aesthetic significance is reduced by the introduction of visually intrusive metal guardrail along the length of the bridge, reducing the vehicular carriageway and giving a somewhat

cluttered appearance to the bridge. The technical significance is reduced because Percy Allan specifically designed his Allan trusses to allow external footways, not internal footways, as shown in Figure 2.12.

External footways have been provided temporarily at Victoria Bridge when repair works necessitated closures of the internal footway, and the need for temporary external footways has necessitated the replacement of all short cross girders with long cross girders to support the footway. This, in turn, has detracted from both the aesthetic and the technical significance of the bridge because of the addition of unsightly cross girders protruding from the sides of the bridge and because of the structural inefficiencies of these additional members with no permanent or apparent function. Therefore, both the aesthetic and technical significance could be greatly enhanced by provision of a suitably designed new footway external to the truss as Allan had intended, and the removal of the existing intrusive internal footway.

Victoria Bridge is of substantial importance to the local and regional community, being highly esteemed for its historical value and its contribution to the town's sense of identity as a historical town. However, Victoria Bridge is also of substantial importance for its amenity, providing a vital link for pedestrians, and an important bypass to reduce congestion in the main part of town.

The narrow width of the bridge restricts it to a single lane of traffic, and with sustained population growth, congestion continues to increase especially in the morning and afternoon peaks, causing increased risks of incidents on the bridge and in the vicinity as well as increased difficulty in accessing the bridge in order to carry out necessary maintenance works. This has led to sporadic calls to provide a more substantial crossing to alleviate the congestion.

Victoria Bridge is rare as one of only six remaining early Allan truss bridges constructed with the early form of top chord splice detailing (and as one of only two that retain this particular detail, at least in part) and as one of only twenty remaining Allan truss bridges of approximately 100 built. Therefore, the Allan trusses and particularly the original top chord details should be conserved. Victoria Bridge is representative as a fine example of an Allan truss bridge, outstanding due to the esteem in which it is held, and also due to its integrity to the original design as an early Allan truss. Therefore, the Allan trusses should be conserved in such a way that they continue to be esteemed. The representativeness could be enhanced by reinstating original details which have been modified, as there remains sufficient evidence of the original design to provide the opportunity for reconstruction of the trusses within the bounds of Articles 19 and 20 of the Burra Charter.

4.2 Constraints and opportunities from current listings

4.2.1 Summary and assessment of current listings

The *Environmental Planning & Assessment Act 1979* gives local governments the power to protect places of heritage significance through local environmental plans (LEP), which include provisions for development controls and identify any incentives that council may offer. Victoria Bridge is listed on the schedule of heritage items in the Wollondilly Shire Council Local Environmental Plan.

Section 170 of the *Heritage Act 1977* requires government agencies to identify, conserve and manage heritage assets owned, occupied or managed by that agency. It also requires that the government agencies keep a register of heritage items. The progress of agencies in preparing registers and managing their heritage assets is monitored by the Heritage Council. In accordance with the Heritage Act, Roads and Maritime has established a Heritage and Conservation Register to record all heritage items in its ownership or under their control, including Victoria Bridge.

The NSW Heritage Council developed seven criteria gazetted under section 4A (3) of the *Heritage Act 1977* to help guide decisions about whether an item is of State heritage significance. Victoria Bridge has been assessed against these criteria above and six of the seven criteria are satisfied at a State level. Section 33 (3) of the *Heritage Act 1977* states that, in general, two or more criteria need to be satisfied for the Heritage Council to recommend State listing. Victoria Bridge clearly meets the criteria for listing and so is rightly listed on the State Heritage Register.

A summary of the statutory and non-statutory listings of the bridge is provided in the following table.

Table 4-1: Summary of the statutory and non-statutory listings of Victoria Bridge

Register / List	Brief Explanation	Meets Criteria	Listed
World Heritage List	Properties forming part of the cultural and natural heritage which the World Heritage Committee considers as having outstanding value.	No	No
Commonwealth Heritage List	A list of natural, indigenous and historic heritage places owned or controlled by the Australian Government.	No	No
National Heritage List	Places of outstanding heritage significance to Australia, including natural, historic and indigenous places of outstanding value.	No	No
State Heritage Register	A list of places and objects of particular importance to the people of New South Wales, including items in both private and public ownership.	Yes	Yes
Section 170 Heritage Register	Lists Roads and Maritime's assets which have been identified as having State or local heritage significance	Yes	Yes
LEP Heritage Schedule	List with maps in principal legal document for controlling development and guiding Council's planning decisions.	Yes	Yes
Register of National Trust	Non-Statutory register identifies historic places of national and local significance through expert committees.	Yes	Yes

4.2.2 Statutory context for conservation and management

The NSW timber truss road bridges are recognised as items of State and local heritage significance and some may also have national heritage values. They are therefore subject to a range of heritage-related environmental planning legislation which provides the statutory framework for managing heritage in New South Wales. Working within the bounds of this statutory framework as described in this section will assist in giving the Heritage Council the required level of assurance that the timber truss bridges are going to be managed and conserved into the future.

4.2.3 State Heritage Register listing and Heritage Council of NSW Approvals

The SHR is a list of heritage items of particular importance to the people of New South Wales. It includes items and places (buildings, works, relics, movable objects or precincts) of State heritage significance

endorsed by the Heritage Council of NSW and the Minister. The SHR is established under Section 22 of the *Heritage Act*, and pursuant to Section 57(1) of the Act, the approval of the Heritage Council of NSW is required for any proposed development within the site including subdivision, works to the grounds or structures or disturbance of archaeological 'relics'.

The *Heritage Act* requires minimum standards of maintenance and repair for items on the SHR to ensure heritage significance is retained. These standards are set out in the *Heritage Regulation 2012*, and relate to weatherproofing, fire protection, security and maintenance.

4.2.4 Exemptions from Heritage Act approval

Section 57(2) of the *Heritage Act 1977* provides for a number of exemptions to Section 57(1) approval requirements, meaning that a Section 60 approval does not need to be sought.

Routine maintenance and minor repairs consistent with standard exemptions would not require Heritage Council approval before commencing. Certain minor developments may be exempt if they are identified in an endorsed bridge specific CMP. Other works including minor structural alteration, major refurbishment, safety and operational upgrades, would require approval of the Heritage Council of NSW, either as a Section 57 exemption or a Section 60 application.

4.2.5 Archaeology

The *Heritage Act 1977* affords automatic statutory protection to 'relics'. The Act defines a 'relic' as:

- *any deposit, artefact, object or material evidence that:*
- *relates to the settlement of the area that comprises New South Wales, not being Aboriginal settlement and*
- *is of State or local heritage significance.*

Any excavation or works to a site listed on the SHR likely to disturb relics would require an approval to carry out a Section 57(1) activity, except in accordance with a gazetted exemption.

In the event that substantial or unexpected archaeological relics are encountered within the curtilage, the Office of Environment and Heritage (OEH) should be notified, pursuant to Section 146 of the *Heritage Act 1977*. Further assessment, and possibly further approval, may be required at the discretion of OEH. The Roads and Maritime archaeological protocols cover the process to be followed in such circumstances.

4.2.6 Aboriginal heritage

Legislative protection of Aboriginal objects and places is provided by the *National Parks and Wildlife Act 1974* (NPW Act). It is an offence under that Act to disturb or otherwise alter Aboriginal archaeological items without the express permission of the Director General of the NSW National Parks and Wildlife Service (NPWS). The Act provides statutory protection for all Aboriginal objects and places (consisting of any material evidence of the Indigenous occupation of NSW) under Section 90 and for 'Aboriginal places' (areas of cultural significance to the Aboriginal community) under Section 84. Aboriginal objects and places are afforded automatic statutory protection in NSW whereby it is an offence to damage, deface or destroy Aboriginal sites without prior consent.

4.2.7 State owned Heritage Management Principles

The State Owned Heritage Management Principles were issued in 2004 under Section 170A (2) of the *Heritage Act 1977*. The following items are particularly relevant to timber truss road bridges which are to be retained:

Table 4-2: Summary of relevant provisions of the *State-owned Heritage Management Principles* (2004)

Citation	Quotation	Implication
3. Lead by Example	State agencies should lead by example by adopting appropriate heritage management strategies, processes and practices. The public sector should set the standard for the community in the management of heritage assets.	Conservation should be of the highest standard.
4. Conservation Outcomes	Heritage assets should be conserved to retain their heritage significance to the greatest extent feasible. State agencies should aim to conserve assets for operational purposes or to adaptively reuse assets in preference to alteration or demolition.	Significance should be conserved to the greatest extent feasible.
8. Maintenance of Heritage Assets	Heritage assets are to be maintained in a manner which retains heritage significance, with the objective of preventing deterioration and avoiding the need for expensive “catch-up” maintenance and major repairs.	Bridges should not be allowed to fall into disrepair despite any load limits.
9. Alterations	Alterations should be planned and executed to minimise negative impacts on heritage significance (including curtilage and setting), and appropriate mitigating measures should be identified.	Any alterations must minimise negative heritage impacts.

The Heritage Asset Management Guidelines were issued in 2004 under Section 170A (3) of the *Heritage Act 1977*. The following items are particularly relevant to timber truss road bridges which are to be retained:

Table 4-3: Summary of relevant provisions of the *Heritage Asset Management Guidelines* (2004)

Citation	Quotation	Implication
2.2 Adoption of the Burra Charter (p 17)	State agencies should adopt the Burra Charter for the making of management decisions for heritage assets. In accordance with the Burra Charter, management decisions should also consider other factors affecting the future of a heritage asset such as the owner’s needs, resources, external constraints and its physical condition.	Management decisions need to be made in accordance with the Burra Charter.
3.6 Interpretation of Heritage Significance (p 20)	The heritage significance of many heritage assets is not readily apparent and should be explained by interpretation, in accordance with the document, Heritage Interpretation Guidelines. Interpretation should enhance understanding and enjoyment, and be culturally appropriate.	A Heritage interpretation strategy should be prepared for each bridge and the population.

3.27 Contemporary & Design Excellence of New Additions (p 25)	New additions to heritage assets, including new constructions in the vicinity of heritage significance, should be identifiable as having been designed and built in the present. New additions are to include contemporary design elements and materials as appropriate, as well as being sympathetic to identified heritage values. Designs should be executed with appropriate materials and finishes.	Any new work on the bridges must exhibit engineering excellence and be sympathetic to heritage value.
3.29 Removal of Intrusive Elements (p 25)	Wherever practical, elements identified as being “intrusive” to the heritage significance of a heritage asset should be removed.	Intrusive elements should be removed.

4.2.8 State Agency Heritage and Conservation Registers

Section 170 of the *Heritage Act 1977* requires that all Government departments or agencies must maintain a Heritage and Conservation Register, which includes all assets owned or in the care and control of the relevant department or agency that are of State or local heritage significance.

All timber truss bridges under the care and control of Roads and Maritime are included in the relevant Heritage and Conservation Register. Under Section 170A of the *Heritage Act*, 14 days prior notice to the Heritage Council of NSW is required in the event that Roads and Maritime:

- 1) removes any item from its register under Section 170; or
- 2) transfers ownership of any item entered in its register; or
- 3) ceases to occupy or demolishes any place, building or work entered in its register.

4.2.9 Local Environmental Plan Listing and Wollondilly Shire Council Approvals

The Wollondilly Local Environmental Plan 2011 (LEP) aims to make local environmental planning provisions in accordance with the relevant standard environmental planning instrument under Section 33A of the *Environmental Planning and Assessment Act 1979*. One of the stated aims of the LEP (Clause 1.2 (2b)) is to protect, conserve and enhance the built, landscape and Aboriginal cultural heritage. Although the bridge is listed on the LEP, this does not restrict or prohibit any development by Roads and Maritime Services, as Clause 5.12 states that,

Infrastructure development and use of existing buildings of the Crown

- *This Plan does not restrict or prohibit, or enable the restriction or prohibition of, the carrying out of any development, by or on behalf of a public authority, that is permitted to be carried out with or without development consent, or that is exempt development, under State Environmental Planning Policy (Infrastructure) 2007.*
- *This Plan does not restrict or prohibit, or enable the restriction or prohibition of, the use of existing buildings of the Crown by the Crown.*

The State Environmental Planning Policy (Infrastructure) 2007, Clause 94 (1) states that,

Development for the purpose of a road or road infrastructure facilities may be carried out by or on behalf of a public authority without consent on any land.

4.2.10 Obligations from non-statutory listings

Victoria Bridge at Picton is listed by the National Trust and by Engineers Australia. The listing by the National Trust is an indication of the social significance of the bridge which should be conserved and enhanced. The listing by Engineers Australia is in the form of the plaque which was never installed on the bridge. This plaque should be installed and maintained at the bridge.

4.3 Constraints and opportunities from operational requirements

4.3.1 Roads and Maritime strategic priorities

As part of its road network management responsibilities, Roads and Maritime manages almost six thousand bridges and major culverts. The Roads and Maritime 2020 Strategic Plan (August 2015) outlines strategic priorities, and conforming to these strategic priorities is a requirement for all Roads and Maritime activities, including maintaining timber truss bridges as operational assets.

In 2012, Roads and Maritime and the NSW Heritage Council agreed upon a strategy for the future management of the forty-eight timber truss bridges then controlled by Roads and Maritime. This strategy recognised Roads and Maritime's role as the custodian of the heritage significance of the population of timber bridges as well as its responsibility to provide safe road infrastructure at reasonable cost in an environment of increasing vehicle size and growing traffic volumes.

In accordance with the endorsed Strategy, a small number of timber truss bridges, including Victoria Bridge, are to be conserved by traditional methods and materials where possible, being situated in locations where traffic is not expected to exceed their original design load.

Although Victoria Bridge is not required to carry very heavy vehicles, and therefore loads are not expected to exceed the original design loads, the bridge is required to carry considerably larger volumes of both vehicles and pedestrians than originally anticipated, and the fact that it is a narrow single lane bridge is beginning to cause difficulties for the local community. Given the town's proximity to Sydney, it can only be expected that this congestion may continue to grow.

Closures of Victoria Bridge for either regular maintenance or for emergency repairs have always caused considerable inconvenience to the locals who rely on the bridge for either vehicular, cyclist or pedestrian access. Traditional methods and materials used in timber truss bridge maintenance necessitate regular and lengthy closures, and this is especially the case at Picton where safety issues are exacerbated by the narrowness and height of the bridge.

When Victoria Bridge is closed, the traffic is diverted by the route shown in Figure 4.1, directing thousands of additional vehicles per day through the main street of Picton, causing considerable problems for the local community and businesses. While the detour would usually add only five minutes to a journey, when thousands of vehicles are using it, the additional travel time becomes considerable. It is primarily during these regular closures required for maintenance that complaints are made regarding, "massive bottle-necks along Argyle Street" and that calls are made for 'providing a proper bypass for Picton because the Victoria Bridge keeps getting closed all the time'.

Figure 4-1: Detour

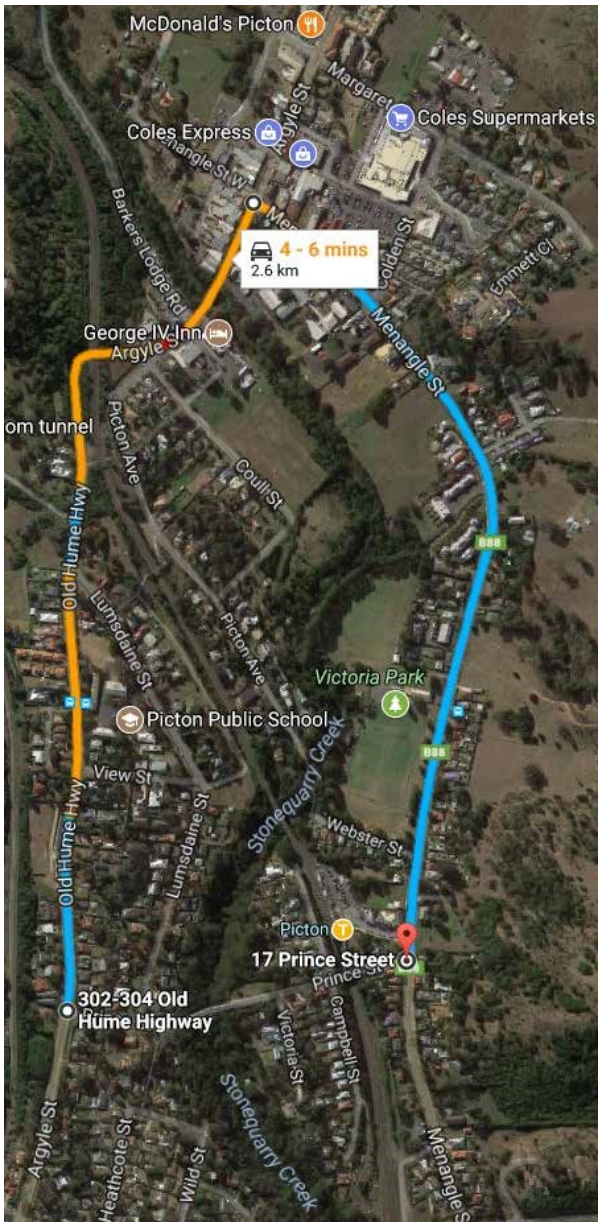

Source: Google Maps

For these reasons, Roads and Maritime attempts to schedule necessary maintenance closures during the Christmas holidays when traffic volumes are somewhat reduced. However, this means that urgent works are sometimes delayed, and this increases the risk of emergency works being required, which then tend to cause more lengthy bridge closures and worse community disruption.

Meeting customer and community needs

Victoria Bridge is highly esteemed for its historical value and its contribution to the town's sense of identity as a historical town. However, Victoria Bridge is also of substantial importance for its amenity, providing a vital link for pedestrians, and an important bypass to reduce congestion in the main part of town. Unfortunately, the narrow width of the bridge restricts it to a single lane of traffic, and with sustained population growth, congestion continues to increase especially in the morning and afternoon peaks, causing increased risks of incidents on the bridge and in the vicinity as well as increased difficulty in accessing the bridge in order to carry out necessary maintenance works. Frequent complaints to the local Council of congestion have been occurring for the past ten years since the bridge last reopened after major repair works to the abutment. The congestion has reportedly led to daily accidents and there are a number of calls for a second crossing.

The primary needs of the local community for the crossing are for pedestrians (especially for daily access to the train station), passenger vehicles (primarily locals, but also including tourists) and the ambulance in case of emergencies. It would be prudent to also allow fire engine access. These community needs are not dissimilar to the needs of the community in the late 1800s which caused the bridge to be constructed in the first place. Particularly, the bridge was originally constructed to meet the needs of pedestrians to be able to safely cross the valley to access the train station and the needs of local and regional businesses to be able to transport their goods. It is therefore very appropriate that the bridge be conserved in such a way to continue this use for which it was built.

4.4 Constraints and opportunities from condition and integrity

Table 4-4: Summary of constraints arising from condition and integrity of Victoria Bridge

Elements	Constraints	Opportunities
Top Chords	Timber is not original fabric and cannot be returned to original fabric. Termite and rot necessitates replacement.	Condition and integrity improved by replacing with new hardwood timbers of original dimensions and detailing.
Bottom Chords	Timber is not original fabric and cannot be returned to original fabric. Original configuration has been lost and cannot be restored due to durability concerns. Original design susceptible to failure and is very disruptive to repair.	Opportunity exists to investigate how best to enhance significance and understanding of the heritage values of the bottom chords of the bridge.
Principals and Diagonals	Timber is not original fabric and cannot be returned to original fabric. Termite and rot necessitates replacement.	Condition improved by replacing as necessary with new hardwood timbers of original dimensions and detailing.
Tension Rods	Some tension rods are original fabric in poor condition. Some are not original fabric or design and are intrusive.	Condition and integrity improved by replacing with new metal components of appropriate dimensions.
Cast Iron Shoes	Some metal components are original fabric but condition is poor. Shoes are susceptible to brittle fracture.	Condition and integrity improved by replacing with new ductile cast iron shoes of original dimensions and detailing. Opportunity to preserve original fabric removed from the bridge for future research into 1800s metals.
Sway Braces	N/A	N/A
Cross Girders	Timber is not original fabric, detailing or dimensions and cannot be returned to original. Variable condition. Timber cross girders cannot accommodate a complying traffic barrier.	Condition and integrity of cross girders improved by replacing with new cross girders of original dimensions but different material which does not shrink and can accommodate a traffic barrier.
Stringers and Decking	Timber is not original fabric and cannot be returned to original fabric. Original detailing cannot be effectively reinstated due to shrinkage properties of currently available timber and WHS hazards associated with original materials (tar). Due to shrinkage and deterioration, excessive noise is caused by decking systems which attempt to reflect the original today.	Decking is currently intrusive but if it were reconstructed exactly to its original design, it would still only have moderate significance. There is therefore very limited opportunity to enhance the cultural significance in the decking, other than to reduce its intrusiveness by replacing with a new form of timber deck which performs the original function with similar fabric.

Railing	Timber is not original fabric and cannot be returned to original fabric. Metal guardrail is intrusive. Railing does not meet minimum safety requirements for vehicles, cyclists or pedestrians.	Railings have little significance. There is opportunity to improve safety by replacing with new traffic barriers and sympathetic handrails.
Piers	Timber is not original fabric and cannot be returned to original fabric.	Condition and integrity improved by replacing with new hardwood timbers of original dimensions and detailing.
Abutments	Timber is not original fabric and cannot be returned to original fabric.	Condition could be improved by replacing Abutment A completely.
Visual context and Setting	Differing land ownerships limit the influence that Roads and Maritime might have on any changes to the visual setting outside of the curtilage.	The visual setting and context for the bridge could be greatly enhanced if the overgrown vegetation were removed and if the height limit portals and signage were removed or relocated.

5. Development of conservation policies

5.1 Current management context

Victoria Bridge at Picton has been managed to a lower standard of repair than other similar Allan truss bridges because of the five tonne load limit, which was expressly applied permanently to the bridge in an attempt to reduce expenditure. While the original intent behind this management methodology was to extend the life of the bridge, it has also caused a number of problems.

When rot or termite attack occurs in a timber truss bridge, if it is not dealt with quickly, the deterioration accelerates, and this increases the likelihood of emergency repairs being required. The presence of rot also greatly increases the risk of fire damage. New South Wales hardwoods used in timber truss bridges are naturally very resistant to fire damage, but if the timber has deteriorated, a fire is much more likely to be able to take hold and cause damage, which is probably what happened in the fire of 2003, where a cigarette butt landed in some rotted timber and therefore was able to cause substantial damage which required the bridge to be closed.

The bridge is therefore highly susceptible to damage due to fire damage (as occurred in 2003), structural failure (as occurred in 2007 with the abutment collapse) and element failure (as occurred in 2010 with the failure of one of the diagonals of the truss). Load limits on timber truss bridges do not prevent such failures, but actually tend to exacerbate the risk of such failures. These failures also considerably diminish the ability of the bridge to demonstrate its heritage value, giving the community no confidence in the strength of the NSW hardwoods or in Percy Allan's design.

Although Victoria Bridge is not in a natural heritage area, it was originally constructed with timber obtained from hardwood forests in New South Wales, which were even then becoming endangered. Unfortunately, the timber in the bridges does not last as long as it takes to grow a new tree of the appropriate species and age to provide replacement members when required.

There are some very clever modern engineered wood products available today which provide substantial strength and durability using imported sustainably grown preservative treated softwoods combined with glass-aramid or carbon-aramid fibres glued together with modern epoxies. However, these are not as strong or as durable as the original ironbark timbers used, and their use would detract substantially from the heritage value of the bridge, a large part of which is the incredible NSW hardwoods which are the very reason for the bridges being constructed.

The elements which demonstrate the unique strength and durability of the NSW hardwoods are the primary load bearing truss elements (top and bottom chords, principals and diagonals).

Round timber girders, sawn timber cross girders and timber piers and abutments have been used in bridges all around the world making use of many different species (both hardwoods and softwoods) which are considerably less strong and less durable than the NSW hardwoods. These elements are therefore not able to demonstrate the unique strength and durability of the NSW hardwoods, and do not contribute substantially to the cultural significance of a timber truss bridge.

5.2 Routine repair works

Routine repair and maintenance works generally required on timber truss bridges are included in the table on the following page. Regular inspections, tightening of bolts, termite treatments and upkeep of good quality protective paint systems are essential for long term conservation.

In the Allan truss, some connections are susceptible to damage from overstress. These include the cast iron shoes which are susceptible to sudden brittle fracture without warning. The splice connections in the timber bottom chord are also heavily stressed and very susceptible to sudden brittle fracture without warning, although this failure is generally precipitated by deterioration of the timber either at splice locations, or at ends of spans where there are numerous timber interfaces.

Timely replacement of deteriorated timber elements is necessary in order to keep the bridge in a safe and serviceable condition and minimise spread of deterioration to other elements. The primary natural agencies causing the deterioration of timbers include rot, termites and fire.

Rot is largely inevitable in timbers containing heart. Timbers containing heart at Victoria Bridge at Picton would generally include cross girders, stringers and timbers in the piers and abutments. Rot occurs in trusses most frequently where water accumulates. In the Allan truss, the following areas are particularly susceptible to rot in addition to heart rot and inspections should focus here:

- Tops of top chords if water is allowed to pond on horizontal surfaces or under flashing
- Interface between principals and diagonals and bottom chord shoes
- Interfaces between timbers in the timber bottom chord, especially at splices and ends
- End grain of all large timbers containing heart, especially cross girders and stringers

The best prevention of rot is use of well-seasoned NSW hardwood timbers (excluding heart where possible) with the highest levels of natural durability and to apply frequent and careful painting.

Termites are major destroyers of timber. It can take three to five years for a new colony of termites to become established enough to damage bridges, but termite colonies are extremely difficult to locate at this early stage. In order for termites to establish a colony, they require food (decaying timber), shelter and moisture, and so moist timber or timbers in moist ground are favoured nesting areas for new termite colonies. Large bridge timbers containing heart (such as cross girders and stringers) that have deteriorated are excellent sites for termite nest establishment, especially those that have formed large checks in the top surfaces causing them to become water reservoirs. It is practically impossible to eliminate all termites from a timber bridge, so the aim is to contain termite activity to a level considered economically acceptable by:

- Annual inspections of the bridge for active termites conducted between October and December, and including treatment of any active termites found in the timber members.
- Follow-up inspections before April of the following year focusing on those members treated to ascertain the success of that treatment and to apply additional treatment where required.
- All inspections and treatment of termites conducted by a suitably experienced and qualified person who is familiar with the tell-tale signs of active termite activity and the likely locations for such activity, who can distinguish between destructive and harmless termite species, who can correctly and appropriately install and monitor termite monitoring dowels and termite baits, who can correctly and appropriately apply termite dust, and who can accurately and clearly record and report on termite activity, locations and treatments.

Although fire damage is relatively rare on timber truss bridges and the hardwoods generally used are slow to burn so that only very few timber truss bridges have been lost due to fire, Victoria Bridge at Picton appears to be particularly susceptible to fire damage, having been badly burned on at least two occasions. These fires have caused considerable damage, requiring substantial closures and significant maintenance work with great disruption to the local community. The risk of fire damage can be reduced by vegetation control in the vicinity of the bridge to form a fire break as well as timely replacement of deteriorated timber to minimise susceptibility to fire damage.

Table 5-1: Cyclical maintenance and management activities required for Victoria Bridge

Component	Every year	Every three years (in addition to every year)	Additional works (as required or specified)
Site & general	<p>Remove any debris and rubbish from the site</p> <p>Clear any vegetation in the area that contributes to a fire hazard or obstructs views</p> <p>Inspect all timber and treat any active termites</p>		Check camber of trusses and re-camber as necessary
Truss timbers not containing heart (top chords, bottom chords, principals and diagonals)	Remove any accumulations of dirt or fauna (with appropriate environmental approvals)	<p>Check for paint damage, clean and repaint as necessary</p> <p>Tighten all bolts</p>	When timber requires replacement due to deterioration (approx. 25-30 years), replace with new timber detailed according to original design drawings
Cross girders and stringers containing heart	Remove any accumulations of dirt or fauna (with appropriate environmental approvals)	<p>Check for paint damage, clean and repaint cross girders as necessary</p> <p>Tighten all bolts</p>	When timber requires replacement due to deterioration (approx. 15-25 years), replace with new timber sized according to original design drawings
Truss span metal components		Check for paint damage, clean and repaint as necessary	If damage occurs to original fabric then new metal components should be fabricated to precisely match originals
Timber decking	Sweep bridge if required	<p>Tighten all bolts</p> <p>Reseal if necessary</p>	When timber requires replacement (approx. 10-15 years), replace with new timber
Timber railings including timber posts and kerbs	<p>Ensure good delineation is maintained by reflectors and paint</p> <p>Check for incident damage, repair and report as necessary</p>	<p>Check for paint damage, clean and repaint as necessary</p> <p>Tighten all bolts</p>	When timber requires replacement (approx. 10-15 years), replace with new timber
Timber piers	Remove any accumulations of dirt or fauna (with appropriate environmental approvals)	Tighten all bolts	When timber requires replacement (approx. 15-25 years), replace with new timber

Timber abutments	Remove any accumulations of dirt or fauna (with appropriate environmental approvals)	Tighten all bolts	When timber requires replacement (approx. 15-20 years) engage a suitably qualified and experienced engineer to design new substructure
------------------	--	-------------------	--

5.3 New work

Due to the changing operational requirements and community needs, new work may be required to ensure the bridge is conserved in the short and long term. The purpose of this section is to explore possible required upgrades at Victoria Bridge. Note that no discussion or assessment of potential heritage impacts is included.

The primary purpose of any new works is to ensure that Victoria Bridge at Picton remains in use by ensuring that it adequately meets the needs of those who use it. The alternatives are as follows:

- Continue to try to manage traffic through signage and load limits: This will continue to cause increasing congestion with increased noise and increased likelihood of accidents. This puts the bridge at risk of damage by accidents or replacement with a concrete bridge.
- Introduce new measures to manage traffic such as traffic lights: Although traffic lights may reduce the risk of accidents, the increasing congestion and noise issues would not be mitigated by traffic lights and so calls for a new concrete bridge would probably still prevail.
- Construct a new concrete bridge for vehicles but keep the timber bridge for pedestrian access: This has been tried numerous times before on many other timber truss bridges and has found to be an ineffective and impractical means of conserving the timber truss bridge. The concrete bridge largely destroys the visual setting and context of the timber bridge (see Figures 5.2 and 5.3), funding priorities lead to a reduced standard of maintenance, putting the bridge at greater risk of fire or other damage, frequent closures and increased safety risks and costs lead to eventual demolition.

5.3.1 Use

Victoria Bridge provides a vital link for pedestrians and an important bypass to reduce congestion in the main part of town. Unfortunately, the narrow width of the bridge restricts it to a single lane of traffic, and with sustained population growth, congestion continues to increase especially in the morning and afternoon peaks, causing increased risks of incidents on the bridge and in the vicinity as well as increased difficulty in accessing the bridge in order to carry out necessary maintenance works. Frequent complaints to the local Council of congestion have been occurring for the past ten years since the bridge last reopened after major repair works to the abutment. The congestion has reportedly led to daily accidents and there are a number of calls for a second crossing.

The traffic requirements for Victoria Bridge will have to be considered in its conservation. Providing adequate traffic and pedestrian access to meet community and road network needs is going to be an ongoing challenge. Options such as alternate routes, widening the bridge to two lanes of traffic and constructing a pedestrian walkway should all be considered as a suite of potential options for this bridge.

From a technical engineering perspective, this is achievable. Other 90' Allan truss bridges were originally designed to accommodate two lanes of vehicles and a designated pedestrian footway. One example is Swan Hill Bridge, for which the original design configuration is given in Figure 5.1.

Figure 5-1: Original design for 90' Allan trusses at Swan Hill

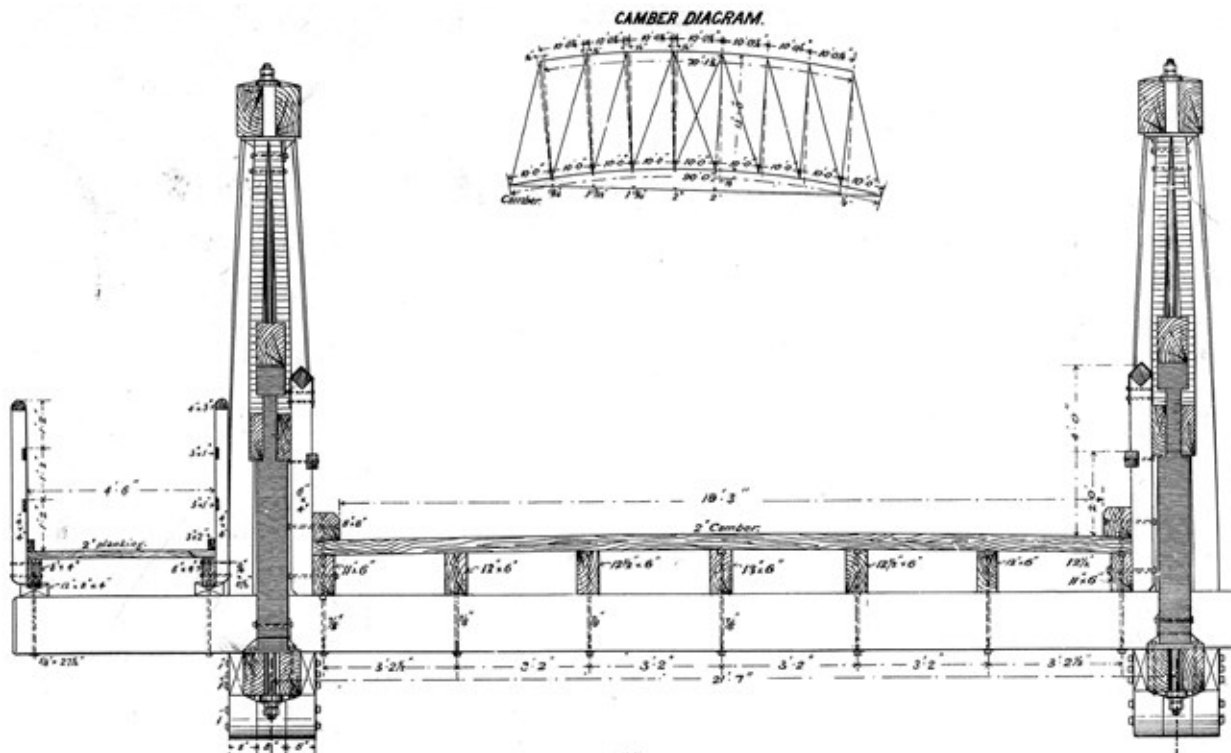

Source: 0067 469 BC 0103

The provision of a permanent external footway at Victoria Bridge would alleviate many issues:

- A suitably designed visually recessive external footway would allow the removal of the existing visually intrusive internal footway which was installed in 1979 (see Figure 2.81).
- The provision of a suitably designed visually recessive permanent external footway would remove the need to install the visually intrusive temporary external footway every time there is a long closure required for bridge repairs (see Figure 2.46).
- A permanent external footway would give a permanent function to the elongated cross girders so that they would not be as visually prominent and intrusive (see Figure 2.69).
- The relocation of the pedestrian footway to the outside of the truss would allow for improvements to the approach footpaths which currently have some sharp turns which would cause difficulties for some users such as those in wheelchairs or on gophers.
- The separation of the road and the pedestrian footway would increase pedestrian safety.

The only required modification in order to accommodate the external footway is the replacement of the sway braces on the upstream side of the bridge with new sway braces. The sway braces, being of moderate significance, could possibly be reinstalled on the downstream side of the bridge in order to provide additional lateral support for the trusses (the cross girders have been elongated on both the upstream and downstream sides despite the temporary external footway only being required on the upstream side). This would be in keeping with some Allan truss designs which have sway bracing at every panel point.

In addition to providing two way vehicular access and permanent pedestrian facilities at Victoria Bridge, the most critical way to conserve the bridge and to ensure its ongoing use is to reduce the need for regular and long bridge closures required for repairs. The decking, stringers and cross girders are currently intrusive as they do not reflect the original design, detract from the trusses and give the whole bridge a “rustic and vernacular” feel rather than expressing the technical excellence of the Allan truss and the superior qualities of New South Wales hardwoods. The replacement of deteriorated timbers also requires frequent full bridge

closures, with considerable community disturbance, again giving the impression that the bridge is past its use-by date.

Figure 5-2: Five Day Creek Bridge (since demolished) with concrete bridge



Source: author 2012

Figure 5-3: Styx River Bridge with visually intrusive new concrete bridge



Source: author 2013

5.3.2 Top chords

The top chords are of exceptional significance as a rare and representative example of the early (1893 to 1897) Allan truss top chord detailing. Currently detracting from this significance is:

- a) Visually intrusive metal flashing: This flashing greatly detracts from the aesthetic significance of the bridge as a whole and also from the ability to interpret the original design of the top chord. The flashing is ineffective in preventing decay and should be removed.
- b) Deterioration of timber: The timber top chords are currently in poor condition, suffering from rot and termite attack, and this detracts from significance and puts the bridge at risk. All timber should be replaced with suitable new timber detailed to the original design.
- c) Modifications to number and locations of splices: The modifications to splice locations and the introduction of additional splices considerably detract from significance, and impair the ability to demonstrate the early Allan truss top chord design. There remains sufficient evidence of the original design in the original drawings and early photographs to allow restoration and reconstruction within the bounds of Articles 19 and 20 of the *Burra Charter*.

5.3.3 Bottom chords

The bottom chords are of high significance, being a distinguishing feature of the Allan truss and demonstrating technical innovation, particularly in the splice detail invented by Allan for his truss.

Unfortunately, there are considerable problems with the original design of the Allan truss bottom chords which were reported within ten years of the first Allan truss opening. They are subject to sudden brittle fracture without warning, thereby putting the whole bridge at risk and they are exceedingly difficult to repair or replace, causing extensive community disruptions. The failures of Allan truss bottom chords historically have not primarily been due to excessively heavy vehicles, but have been primarily due to accelerated hidden deterioration of timber at interface details causing sudden failure at well under theoretical design capacity. The timber available today for Allan truss bottom chords is of considerably less quality than the timber available in the late 1800s when the Allan trusses were first designed and constructed, thereby exacerbating the risk.

Furthermore, at Victoria Bridge the ability to interpret the significance of the bottom chords is currently somewhat compromised by the modifications to the bottom chord layout in all spans. The splice layout varies from span to span and from truss to truss so that they are no longer symmetrical or matching and are therefore visually intrusive. Splices have been moved away from cross girders in an attempt to improve durability. The addition of monorails hanging from the cross girders obstructs views to the bottom chords so that the structural detailing is not easily seen.

The bottom chord detailing in the Allan truss is important not only in understanding the Allan truss, but also in understanding the design evolution of the other types of timber truss bridges. The change from the Old PWD to the McDonald truss was due to increasing loads and new results from timber testing in 1886. The change from the McDonald to the Allan truss was due to increasing difficulty in obtaining large cross section long timbers by the very late 1800s. However, the change from the Allan truss to the de Burgh and Dare trusses was due to failures of the Allan truss bottom chords as well as the increasing availability and economy of metal for use in bridges.

Therefore, conservation works on Allan trusses should aim not only to demonstrate something of the original design intent of the Allan truss bottom chords, but also something of their weaknesses, without, of course, putting the bridge at risk of structural failure due to these inherent weaknesses.

One solution that has been developed for Allan truss bottom chords is the replacement of the timber bottom chords with steel hollow sections of the original dimensions, somewhat similar to what is typically done for cross girders.

Although it is clearly a change in fabric, the advantages of this option are:

- Steel box bottom chord is strong and stable and durable. This steel bottom chord is considerably stronger than Allan's timber bottom chord and is more stable than the various steel plate options (which have no lateral stiffness in the case of flood damage or vehicle impact), and is considerably more durable, having no interface issues with timber facia.
- The steel box bottom chord allows all other details to remain unchanged. It can accommodate the original bottom chord shoes with shear keys and therefore no changes are required to the shoes or the connections or the geometry of the cross girders due to changes in the bottom chords.
- The steel box bottom chord can be used to interpret the original Allan truss timber bottom chord by including metal splice plates at original locations.

Clearly, the best heritage outcome for the bottom chord itself would be to restore the original design. However, due to the fact that this option would put the entire bridge at risk of collapse in the long term, it is considered preferable to replace the bottom chord with a steel box section bottom chord which is designed to maximise interpretability of the original and to minimise other changes to the bridge. Pieces of the bottom

chord timber with original riveted metal splice plates should be used as part of the interpretation strategy of this bridge to assist in understanding.

5.3.4 Principals and diagonals

The principals and diagonals are of high significance as aesthetically distinctive, representative examples of the Allan truss design. Deterioration is currently detracting from this significance. All deteriorated timber should be replaced with suitable new timber detailed to the original design.

The only visible modification evident on the bridge currently is that bolts have been added to the counterbracing at the centre of each span, whereas the original design and construction had no bolts at the centre where diagonals intersect. When these elements are replaced, care should be taken to ensure that bolts are used only where they were specified on the original drawings.

5.3.5 Tension rods

The tension rods are of moderate significance as representative examples of the Allan truss design. The ability to interpret this significance is currently somewhat compromised by the replacement of some tension rods with new tension rods of considerably larger dimensions which do not match and are visually intrusive, ruining the symmetry of the original paired tension rods and confusing interpretation. Some tension rods are also in poor condition or bent out of shape.

This should be improved by replacement of these tension rods with new tension rods which match the original dimensions, or by upsizing all tension rods in the bridge so that symmetry is restored. If all tension rods are upsized, two different sizes should be used to reflect the original design.

5.3.6 Cast iron shoes

The cast iron shoes are of moderate significance as representative examples of the Allan truss design. These cast iron shoes are susceptible to brittle fracture, as is demonstrated by the fact that many have broken at Victoria Bridge in the past and some are currently broken.

There remains sufficient evidence of the original design in the original drawings and early photographs to allow reconstruction within the bounds of Articles 19 and 20 of the *Burra Charter*.

Broken cast iron shoes put the bridge at considerable risk of collapse, and so the best way to ensure that the bridge is conserved into the future is to replace all cast iron shoes with new shoes cast with ductile cast iron (less susceptible to fracture) cast to the original design dimensions. Another option often considered for replacement of cast iron shoes is welded steel replicas. Although ductile cast iron replicas are significantly more expensive than welded steel, they are more faithful to the original design intent and therefore a better heritage outcome.

5.3.7 Sway braces

The sway braces are of less cultural significance than the other metal elements of the truss span because they are relatively common features and are not primary structural elements of the truss, but secondary elements added to limit deflections and vibrations rather than take loads. These elements are also not essential to the Allan truss because detailing varied somewhat between bridges. Sway braces were shaped quite differently on trusses with external footways, for example, and the sizes of sway braces and the number of sway braces varied between bridges.

5.3.8 Cross girders

The current cross girders are intrusive, detracting from significance rather than contributing to it, having been substantially altered in a visually intrusive manner. Extended cross girders detract from the technical significance of the Allan truss which minimised weights and lengths of timber. The use of white paint to protect the ends of the timber cross girders gives them a visual dominance which was lacking in the original, thereby detracting attention from the trusses.

Although there remains sufficient evidence of the original design in the original drawings and early photographs to allow reconstruction within the bounds of Articles 19 and 20 of the *Burra Charter*, reconstruction of these elements on this bridge is not feasible because of the following:

- f) The extended cross girders are required to ensure that pedestrian access is able to be provided at short notice even during bridge closures for emergency and repair works.
- g) The timber cross girders need to be painted white because that is the best way to prolong the life of the timber. When cross girders were either left unpainted, or coated in tar, they tended to deteriorate more quickly, requiring more frequent bridge closures for member replacements, with the considerable community disruption caused by these closures.
- h) There is a water pipe on the upstream side supported by the extended cross girders.
- i) The original design left insufficient clearance at the ends of cross girders to allow for some deterioration before the sway brace connection becomes ineffective and so all long cross girders are longer than original to reduce the frequency of replacements required.

In addition to the issues mentioned above, the timber cross girders are also incapable of supporting a complying traffic barrier. In order for a safe and complying steel traffic barrier to be effective, it must be solidly connected to something, and it is not possible to achieve a strong enough and rigid enough connection in timber. In the long term, it will therefore be necessary to replace the timber primary cross girders with new cross girders of a different material.

Although it is not practical to restore the original design, the current situation could be substantially improved by replacing these elements with new elements which achieve the function for which the original cross girders were designed and which have a similar form to the original cross girders.

Steel box sections have been successfully used on a number of timber truss bridges to provide adequate strength and durability without detracting from the visual amenity of the bridge. At Victoria Bridge at Picton, given that the cross girders were originally unpainted and visually recessive (as can be seen, for example, in Figures 2.35 and 2.49), efforts should be made in the design of the new cross girders to detail them in a visually recessive way, and it would be most appropriate to restore the original dark shade by painting them dark grey rather than white.

5.3.9 Stringers and decking

The stringers and decking are intrusive, detracting from significance rather than contributing to it, having been substantially altered in a manner detracting from the technical significance of the Allan truss design which was carefully detailed to provide a waterproof deck with superior drainage.

Although there remains sufficient evidence of the original design in original drawings, early photographs and specifications to allow reconstruction within the bounds of Articles 19 and 20 of the *Burra Charter*, reconstruction of these elements on this bridge is not feasible because:

- The quality of timber used originally to provide waterproof timber decks is not available today, so that timber decks today suffer from considerable shrinkage and warping after installation, thereby opening up gaps quickly between timbers and breaking any seals.
- The products originally used to provide the waterproofing for the deck (particularly the tar) are no longer used today due to safety and environmental concerns.
- Attempts in the past to retain as much of the original detailing as possible on this bridge lead to excessive noise, especially given this bridge's location among many residences.

Even with all the intrusive modifications, the current stringers and timber deck are still problematic:

- Safety issues for vehicles due to slipperiness and protruding loose bolts
- Safety issues for cyclists due to shrinkage gaps and roughness
- Safety issues for pedestrians due to trip hazards
- Community issues due to excessive noise when planks become loose
- Community inconvenience due to regular bridge closures required to maintain the deck and its running surface (spray seal), and also length of closures required for full deck replacement (every 7 years for sheeting and every 15 years for decking and sheeting).

Although it is not practical to restore the original design, the current situation could be substantially improved by replacing these elements with a new stress laminated timber (SLT) deck which achieves the function for which the original stringers and decking were designed and which provide a similar form to the original decking, able to be cambered to restore the concept of a waterproof, well drained deck. SLT decks have been successfully used on a number of timber truss bridges to provide adequate strength and durability without detracting from the visual amenity of the bridge.

5.3.10 Railing

Timber rails do not have any ability to prevent a vehicle from falling off the bridge. On the contrary, timber rails are a spearing risk to errant vehicles and their passengers. There have been a number of instances of vehicles driving off the sides of timber truss bridges, with some fatalities. Roads and Maritime has a legislative responsibility for the safety of the travelling public and it is therefore necessary that Roads and Maritime do what it can to mitigate this well known risk.

A number of different approaches to barrier rail design have been investigated in attempts to minimise the visual impact and obtrusiveness on heritage bridges. The barriers generally proposed for timber truss bridges are not designed to meet the current Australian Standard (AS 5100-2017), but an earlier standard (AUSTROADS-96). The geometrical requirements and the design loads are significantly less stringent in AUSTROADS-96, which is the absolute minimum required to keep a small errant passenger vehicle safe. The traffic barrier must provide safety not only for errant vehicles, but also for cyclists and inspection and maintenance personnel.

Steel traffic barriers have been installed on a number of timber truss bridges with varying levels of visual intrusiveness. After trialling various concepts, Roads and Maritime have worked with an architect to develop a more visually recessive traffic barrier.

5.3.11 Piers

The piers are of high significance, being the tallest timber trestle piers in New South Wales. They are aesthetically distinctive and have landmark qualities due to their scale. Unfortunately, there are considerable difficulties associated with these very tall timber piers which must be considered:

- 1) The tall timber piers appear to be particularly susceptible to fire damage.
- 2) The bases of the piers consist of unreinforced concrete which is beginning to show signs of distress (cracking) and will probably require replacement in the medium to long term.
- 3) The bases of the piers are simply sitting on rock, and this rock is susceptible to scour, as has been demonstrated by the scour that occurred in the June 2016 flood.
- 4) The timber trestle piers are located on steeply sloping banks, and these banks are likely to erode in time due to natural weathering, vegetation growth and heavy rains, meaning that the bases of the piers are at some risk of being hit by rock boulders rolling down the banks (as discussed previously, this could be triggered by heavy rains or by an earthquake).
- 5) The timbers both for the primary pier columns and also for the pier bracing consist of very large section timbers which are increasingly difficult to obtain. The use of shorter timbers considerably weakens the piers, leaving them more susceptible to damage from overstress.
- 6) Access for maintenance is very limited, and so bridge closures are generally required in order to make any repairs to the piers including replacement of deteriorated timbers. These bridge closures are increasingly difficult to arrange as the population of Picton increases.
- 7) The great height of the piers combined with the steepness of the banks means that there is considerable difficulty in inspecting the piers, so some form of safe access is required.
- 8) If the bridge is widened to accommodate two lanes of traffic then the piers would also require widening so that the primary load bearing columns remain under the trusses.

In the short term, action should be taken to ensure that any deteriorated timbers in the piers are replaced in a timely fashion and that regular vegetation clearing is undertaken to reduce the fire hazard, given that deteriorated timber is considerably more vulnerable to fire than new timber. Scour protection should also be provided to reduce the risk of scour undermining the piers.

In the long term, the unreinforced concrete bases should be replaced with reinforced concrete pile caps on bored concrete piles which will remove the risk of collapse due to scour damage in the future. Some form of protection, possibly in the form of concrete walls, should be provided to mitigate against the risk of boulders rolling down the steep banks and knocking over the piers.

If the bridge is widened to accommodate two lanes of traffic then the timber trestle piers should be reconstructed slightly wider in order to accommodate the new widened trusses while retaining the original design intent of the piers with regard to the flow of forces and the connection details.

In the light of the considerable risks and difficulties faced in maintaining the very tall timber trestle piers at Victoria Bridge, there may come a time in the future when this is no longer practical.

5.3.12 Abutments

Long term options for the bridge abutments will have to be considered in its conservation. As the ground profile at both ends of the bridge has been so modified over the years with much concrete already introduced, it is not possible to restore the original design of timber abutments. New concrete abutments were included in the original detail for some timber truss bridges (e.g. Morpeth Bridge and the timber truss bridge over Crookwell River) and have subsequently been done on a number of other timber truss bridges (e.g. Barham Bridge and Becker's Bridge).

On some bridges (not timber truss bridges) attempts have been made to hide the concrete abutments with a layer of timber facia (e.g. Dalgety Bridge), but this is poor heritage practice (note to Article 22 of the *Burra Charter* states that imitation should generally be avoided) as well as a poor structural outcome (the connections for the timber facia as well as the presence of the timber facia collect moisture, attract termites and give a poor visual outcome with time as deterioration of timber and corrosion occurs).

Another option considered for minimising the visual impact of the concrete abutments is to replace the current retaining-wall-type abutments with spill-through-type abutments, which have a much smaller exposed area of concrete. Unfortunately, at Victoria Bridge the steep banks are such that spill-through abutments are not possible. Efforts, however, should be made to minimise the size of the abutments and to keep them as neat and visually unobtrusive as possible. An additional conservation benefit of introducing concrete abutments is that these separate the timber trusses from the ground, and therefore provide some protection from termite attack (in addition to the regular inspections and termite treatments which are done). This is especially important at Victoria Bridge where the community is considerably disrupted each time major repair is required.

Abutment A is currently in very poor condition and in urgent need of replacement. The new concrete abutment should be designed and constructed to accommodate future widening and the permanent external footway as described in Section 5.3.1. The existing drainage issues from the road approaches at the Abutment A end of the bridge should also be fixed as part of this work. Although the fabric of Abutment B is currently in good condition, the heritage integrity is poor, with the design being completely different to the original in every aspect except for visually. The new Abutment B has considerably weakened the bridge, removing the longitudinal restraint originally provided by the abutment. The expected life of the geofam which was used behind Abutment B is approximately 15 to 20 years, but the sandstone on the embankment behind the geofam continues to bulge, indicating that the whole embankment approach requires considerable work.

The embankment approach is outside of the curtilage of the bridge and outside of the control of Roads and Maritime, and so it will fall to the local Council to arrange for this critical work to be done. However, there should be coordination between the local Council and Roads and Maritime to ensure that a robust and durable abutment is provided at Abutment B at the first opportunity.

5.3.13 Visual setting and context

The visual setting of the bridge currently detracts somewhat from the technical and aesthetic significance as the signs warning of dangers on the bridge (gaps in deck), the signs warning of the limited capacity of the bridge (5 tonne load limit) and the very prominent portals designed to ward off large trucks (Figure 2.54) do not inspire confidence in the strength of Allan's design or in the amazing properties of the NSW hardwoods, the best timbers in the world for bridge building.

Victoria Bridge at Picton would be much better able to demonstrate the true significance of the Allan truss design if the bridge were repaired and restored and load limits removed. However, it is understood that not only the bridge is load limited, but also the road. Given the poor condition of the approach embankment which is under the local Council's responsibility, it would not be sensible to remove the load limit from the road until the embankment has been stabilised.

However, less intrusive options for enforcing the 5 tonne load limit should be considered so that the portals can be removed, restoring some of the original views to and from the bridge. On some bridges, CCTV cameras have been installed as an effective deterrent from illegal use. This, or some other technology, should be considered for installation along the road (preferably well clear of the bridge) to provide adequate safety without detracting from the significance of the bridge.

6. Conservation policies

The policies in this section provide for the care and management of Victoria Bridge to ensure its conservation as a State Heritage item. The policies provide for the retention and enhancement, through appropriate conservation and interpretation, of the heritage values of the bridges including their settings and ongoing operations.

The Overarching CMP contains policies designed to guide and manage the entire collection of timber truss bridges that are to be retained by RMS. These general policies identify the broader principles and practices that are to be undertaken and may not specifically apply to an individual bridge. For clarity these policies have been omitted from this bridge specific CMP. It is important that this CMP be read in conjunction with the Overarching CMP to ensure a comprehensive approach to managing change.

Policies from the Overarching CMP specific to Victoria Bridge (Policies 1–10) and policies relating specifically to elements of the bridge are included (Policies 11–21).

6.1 Best practice in heritage management

The policies in this CMP provide for the care and management of Victoria Bridge to ensure its conservation as a State Heritage item. The policies provide for the retention and enhancement, through appropriate conservation and interpretation, of the heritage values of the bridges including their settings and ongoing operations.

Policy 1: Retention of the cultural significance of Victoria Bridge

- a) Victoria Bridge is a place of exceptional cultural significance and will be maintained and conserved in such a way which protects or enhances their cultural significance.
- b) Conservation of Victoria Bridge will accord with the definitions and principles of The Burra Charter: the Australia ICOMOS Charter for Places of Cultural Significance and include all significant components and attributes of the place and its setting.
- c) All current and future owners, managers and consent authorities responsible for the care and management of Victoria Bridge and/or its setting will be advised of, and be jointly responsible for, the conservation of the heritage significance of the bridges.
- d) The conservation management of Victoria Bridge will be undertaken in consultation with heritage practitioners with relevant expertise and experience working in collaboration with structural engineers with relevant expertise and experience as required.

Policy 2: Adoption, implementation and review of the CMP

- a) The conservation policies set out in this document will be formally adopted by Roads and Maritime as a guide to future conservation and development of Victoria Bridge.
- b) Roads and Maritime will make resources available for the implementation of these policies during any works to the bridge or its setting, including routine maintenance.
- c) Roads and Maritime will ensure that this document is both available for, and understood by staff coordinating and undertaking the ongoing maintenance of Victoria Bridge.
- d) This CMP will be made available to the public. Copies of this CMP will be lodged with all relevant administrative, maintenance, heritage and archival bodies/agencies, as well as being held by Roads and Maritime, and be readily available for public reference.
- e) This CMP will be reviewed every five years to incorporate any changes in conservation methodology or practice, changes in legislation or user requirements, and any new historical evidence that comes to light. The effectiveness of conservation treatments to the structures will also be considered and if

required, corrective action recommended. The reviewed CMP will be submitted to the Heritage Council for endorsement.

6.2 Ensuring bridges have a role and use in life of communities

The continued use of Victoria Bridge as a functioning crossing for vehicles and pedestrians is integral to its cultural significance and survival. New work will be required to adapt the bridge to changing transportation needs.

Policy 3: Use of the bridge

- a) Roads and Maritime will continue to engage with local communities to ensure that Victoria Bridge is retained and managed in a way that meets community needs.
- b) Victoria Bridge will be used for vehicular traffic. The continued use of this bridge as a functioning crossing for vehicles and pedestrians is integral to its cultural significance
- c) Unacceptable uses of Victoria Bridge include any uses or activities that may cause or accelerate damage to the fabric or views to and from the bridge (e.g. utilities).
- d) Roads and Maritime will consider arranging for the removal and relocation of existing utilities from Victoria Bridge if possible and if opportunity arises.

Policy 4: Maintenance and repair

The timber in timber truss bridges is generally not original fabric, and requires replacement from time to time. Original designs were specifically detailed to accommodate these regular replacements of timber elements, and so the removal of deteriorated fabric and its replacement with new timber fabric of suitable species is essential for the conservation of these bridges.

- a) Ongoing repair and maintenance will be carried out to ensure that the minimum standards of maintenance under the Heritage Act are met, and that each significant element in Victoria Bridge retains its level of significance. Works will be undertaken by suitably skilled workers with proven expertise in the relevant field and under adequate supervision.
- b) Roads and Maritime will prepare an Incident Response Plan for Victoria Bridge to minimise the risk and duration of emergency works, and manage such works so that the public and the bridge is kept safe, and so that works do not impact significant fabric.
- c) Victoria Bridge is located on a public road and must not create a public safety hazard, but will be maintained both to support its ongoing functionality and its significant form.
- d) Victoria Bridge will be regularly inspected by specialists for the integrity of the structure. Any issues affecting public safety, if found, will be addressed by appropriate methods.
- e) A separate specialist will be engaged twice a year to inspect for and treat any termites.
- f) In order to carry out maintenance and repair work safely, various support structures may be necessary including Bailey bridge (or equivalent), temporary props and access scaffolding. These structures are temporary in nature, and will be removed when no longer required.

Policy 5: New work

New work will be required to adapt Victoria Bridge to changing transportation needs. The endorsed Strategy and overarching CMP acknowledged the need to include the use of modern materials in order to ensure that bridges have sufficient strength and safety for modern vehicles.

These policies aim to ensure that new works and new materials are not damaging to heritage significance, but are comparable with the old in quality and do not dominate the trusses in bulk, scale or character. Appropriate contemporary design using modern materials and techniques can be an effective way of distinguishing new work from original so long as it is used with care and design excellence.

- a) Elements of Victoria Bridge will be conserved in accordance with their level of significance.
- b) Victoria Bridge will continue to carry traffic appropriate to its place in the road network. It may be adapted to ensure continued serviceability provided this does not compromise its heritage significance. Subject to relevant approvals, this may include introducing new materials to meet load, safety and durability requirements.
- c) Roads and Maritime will match the excellence of the originals in the quality of design and construction of any modifications or new works.
- d) For works not covered by Standard or Specific Exemptions or by exemptions identified in an endorsed bridge specific CMP, applications to the Heritage Council for approval for specific works will be submitted, accompanied by a statement of heritage impact (SOHI) and, if required, the relevant statutory application under the *Heritage Act 1977*. The approval and decision making process for structural upgrades is given on the following page.

6.3 Interpretation and appreciation of timber truss bridges

There are perceptions with regard to heritage timber truss road bridges (e.g. they are inherently too weak for modern vehicles, they are inherently unsafe, they are inherently noisy, heritage listing inherently prohibits any change). This not only means that the bridges are not fully appreciated, but these perceptions can also lead to local communities lobbying for a new concrete bridge, often wishing to conserve the timber bridge off line only when it is too late. Accurate, interesting and relevant interpretive material is critical for assisting local and regional communities to appreciate their timber truss bridges, which will, in turn, assist with conservation.

Policy 6: Interpretation

- a) The heritage significance of Victoria Bridge will be communicated through effective heritage interpretation.
- b) Interpretation of Victoria Bridge will be based on the historical themes and historical analyses documented in this CMP.
- c) Interpretation will conform to the Heritage Division's Interpreting Heritage Places and Items Guidelines and with Roads and Maritime's Heritage Interpretation Guideline.¹³²
- d) A suitably designed sign will be installed and maintained at an appropriate viewing location to provide interested visitors with relevant information.
- e) In consultation with Engineers Australia, the Engineers Australia plaque will be installed on a stone block at the south west end of the bridge as had been intended in 2003.
- f) Interpretation will include a publicly accessible sample of a timber bottom chord at the splice including original riveted metal splice plates as well as bolts and washers.

¹³² NSW Heritage Office, Heritage Information Series, Interpreting Heritage Places and Items Guidelines, 2005; NSW Roads and Maritime, Heritage Interpretation Guideline, Draft February 2016.

Policy 7: Protection and enhancement of visual setting

- a) Any development proposed for the land adjacent to Victoria Bridge, whether inside or outside the curtilage, should be considered carefully to ensure that it does not have an unacceptable visual impact which could cause a reduction in the aesthetic significance of the bridge.
- b) Signage in the vicinity of Victoria Bridge should be minimised to what is necessary for safety and identification so that it does not create visual clutter and block views.
- c) Vegetation in the vicinity of Victoria Bridge should be kept to a minimum. Weeds should be removed, and vegetation clearance should be taken with a view to improving the visual setting, and to reduce the risk of fire by creating a cleared area that acts as a fire break.
- d) Any relevant planning and statutory controls must be adhered to when considering development or works adjacent to the bridge.
- e) Efforts should be made to enhance the visual setting by removal or relocation of height restriction portals and by provision of appropriate viewing areas with interpretation.

6.4 Documentation and approvals

Well managed records are important as they enhance the understanding of the heritage item, its significance and the impact of change as part of the conservation and management process.

Policy 8: Archival recording

- a) The records created by Roads and Maritime relating to Victoria Bridge are recognised as an integral part of the heritage portfolio. They will be managed to ensure permanent retention as State records, but must also be made available so that they can be readily accessed by bridge managers, engineers and heritage practitioners where required.
- b) Immediately before, during and after any works being undertaken, an inspection will be completed, detailing and photographing the condition and defects of all elements.
- c) A complete archival recording will be undertaken of Victoria Bridge including 3D mapping (laser scanning).
- d) All methods and materials used during any work done to Victoria Bridge will be fully documented with written information and appropriate photographs. Records, reports and photographs of any work carried out on the bridge will be placed in a permanent archive to enable retrieval of information afterwards.
- e) A representative sample of any original fabric assessed to be of heritage significance (such as cast iron shoes), but to be removed from Victoria Bridge will be suitably archived and recorded on the Roads and Maritime Section 170 Heritage and Conservation Register unless similar samples are already archived. This will include:
 - Three different types of original top chord shoes from a 90' Allan truss.
 - Three different types of original bottom chord shoes from a 90' Allan truss.
 - Two different sizes of tension rod assemblies including nuts and washers

Policy 9: Archaeology

- a) Roads and Maritime will consult with relevant Aboriginal stakeholders about any proposed project or works that may impact on areas of Aboriginal archaeological potential or cultural significance. Wherever harm to Aboriginal relics is considered likely in the course of works, an AHIP shall be obtained, in accordance with Section 90(1) of the NPW Act 1974.
- b) Any subsurface disturbance of land that may have archaeological potential will be carried out in accordance with the Roads and Maritime Services Cultural Heritage Guidelines and the archaeological provisions of the Heritage Act 1977. A Due Diligence Assessment will be provided for any works which

disturb the land outside of an AHIP area (including, cutting, filling, ground penetration, stockpiles, mounds, etc). The Assessment shall be in accordance with the NSW Office of Environment & Heritage's Due Diligence Code of Practice for the Protection of Aboriginal Objects in New South Wales (DECCW 2010).

- c) The Roads and Maritime Services *Unexpected Heritage Items Heritage Procedure* (current edition 02, November 2015), must be followed to manage the discovery of all unexpected heritage items (both Aboriginal and non-Aboriginal) that are discovered during Roads and Maritime activities.

Policy 10 – Exemptions and approvals

- a) Routine maintenance works identified in Table 1 of Appendix A can proceed without requiring notification to the Heritage Council.
- b) Works identified in Table 2 of Appendix A will need approval/consent advice sought from the Heritage Division regarding the nature/type of approval required prior to works being planned.
- c) Works identified in Table 3 of Appendix A will need approval from the Heritage Council or its Delegate in accordance with Standard Exemption 6 of Standard Exemptions for Works Requiring Heritage Council Approval. Works (including site preparation) must not commence until the Applicant is advised in writing by the Heritage Council or its Delegate that the works are in accordance with the exemptions endorsed in this CMP.

6.5 Bridge Specific Policies

Policy 11 – Top chords (exceptional significance)

- a) Top chords will be restored by removal of intrusive and ineffective metal flashing.
- b) Top chords will be reconstructed to their original design dimensions and detailing using NSW hardwood of suitable strength and durability and steel splice plates.
- c) The timber of the top chords, once reconstructed, will be preserved for as long as practical by ensuring that the protective coating (breathable white paint) is reapplied as necessary and that termite inspections and treatments are undertaken regularly.
- d) They will be replaced before deterioration affects safety or serviceability of the bridge.

Policy 12 – Bottom chords (high significance)

- a) In the short to medium term, the timber bottom chords will be preserved for as long as is practical by ensuring that the protective coating (breathable white paint) is reapplied as necessary and that termite inspections and treatments are undertaken regularly.
- b) They will be replaced before deterioration affects safety or serviceability of the bridge.
- c) In the long term, consideration could be given to replacing the bottom chords with new steel bottom chords suitably designed to ensure that the risk of sudden brittle failure is mitigated while the original detailing and significance of the bottom chords is able to be appreciated.
- d) The design of the new bottom chords will be developed with due consideration to the original form and function of the Allan truss bottom chord and its connections with other elements (such as cast iron shoes) so the bottom chords do not detract from significance.
- e) Consideration will be given to relocation of the monorail to enhance views to bottom chords.

Policy 13 – Principals and diagonals (high significance)

- a) Principals and diagonals will be reconstructed to their original design dimensions and detailing using NSW hardwood of suitable strength and durability.

- b) The principals and diagonals, once reconstructed, will be preserved for as long as is practical by ensuring that the protective coating (breathable white paint) is reapplied as necessary and that termite inspections and treatments are undertaken regularly.
- c) They will be replaced before deterioration affects safety or serviceability of the bridge.

Policy 14 – Tension rods (moderate significance)

- a) Tension rods should be reconstructed to their original design dimensions and detailing with new metal components. They should be painted black to preserve the original aesthetic.
- b) In the event that new tension rods cannot be reconstructed to their original dimensions due to the difficulties in upsizing threaded ends, all tension rods in the bridge will be replaced with suitably upsized tension rods in two sizes to reflect the original design intent.

Policy 15 – Cast iron shoes (moderate significance)

- a) Cast iron shoes will be reconstructed in ductile cast iron to their original design dimensions and detailing. They will be painted black to preserve the original aesthetic.

Policy 16 – Sway braces (moderate significance)

- a) In the short to medium term, the sway braces will be preserved for as long as is practical by ensuring that the protective coating (black paint) is reapplied as necessary.
- b) Should changes to the bridge be required, such as the relocation of the pedestrian facilities or an upgrade to accommodate heavy vehicles, the design of the new sway braces will be developed so that they do not detract from significance of Victoria Bridge while providing necessary lateral restraint to the top chords.

Policy 17 – Cross girders (currently intrusive)

- a) In the short to medium term, the timber cross girders will be preserved for as long as is practical by ensuring that the protective coating (breathable white paint) is reapplied as necessary and that termite inspections and treatments are undertaken regularly.
- b) They will be replaced before deterioration affects safety or serviceability of the bridge.
- c) In the long term, consideration could be given to replacing the timber cross girders with new steel cross girders. The new steel cross girders should be hollow box sections painted white to indicate as a form of interpretation that the original cross girders were timber.
- d) The design of any steel cross girders will be developed with due consideration to the original design dimensions and connection detailing so that it reflects the original form and function and does not detract from significance.
- e) The design of any steel cross girders will be developed with due consideration for any additional requirements for the bridge (e.g. external walkway, new traffic barrier).

Policy 18 – Stringers and decking (currently intrusive)

- a) The stringers and decking should be replaced with new decking which should reflect the fabric and function of the original and should restore the original aesthetic of the bridge.
- b) The new decking and its wearing surface should be maintained in such a way to ensure the safety of vehicles travelling across the bridge to reduce the risk of damage to the bridge.

Policy 19 – Railing (currently intrusive)

- a) In the short term, the safety risks will be mitigated as much as possible by ensuring that deteriorated timber is quickly replaced, connections are tight and delineation is maintained.
- b) In the long term, the timber railings should be replaced with a new visually recessive but complying traffic barrier and the intrusive metal guardrail should be removed.

Policy 20 – Piers (high significance)

- a) In the short term, the timber of the piers will be reconstructed as necessary to their original design dimensions and detailing using NSW hardwood of suitable strength and durability and steel splice plates of original details.
- b) Once reconstructed, piers will be preserved for as long as is practical by ensuring that termite inspections and treatments are undertaken regularly.
- c) They will be replaced before deterioration affects safety or serviceability of the bridge, and before any fire hazards are created by pockets of easily ignitable rotted timber.
- d) Scour protection should be provided to reduce the risk of scour damage to the piers.
- e) In the long term, the double timber trestle piers may be reconstructed to a modified and wider (transversely) design on new reinforced concrete pile caps with bored concrete piles.
- f) The design of any new piers will be developed so that the original height of timber, which is of considerable significance, is retained. The general form, consisting of double timber trestle piers with timber columns directly supporting the trusses and three tiers of timber bracing will also be retained. Structural enhancement to connections at the base may be considered to ensure appropriate robustness for likely long term loads.

Policy 21 – Abutments (little significance)

- a) The abutments should be replaced with new abutments designed to be visually recessive and sufficiently strong so that the bridge can continue to have a role and use in the life of the community.

7. Implementation of CMP

The conservation policies in Section 6 provide for the ongoing care and management of Victoria Bridge so as to ensure the conservation of its cultural heritage values. A copy of the implementation plan for the Overarching CMP is provided in the table below, which relates to the larger population of bridges.

Year	Action by Roads and Maritime	Priority
Year 1	Submit CMP to OEH for endorsement.	High
	Formally adopt this CMP and integrate with all other documentation, planning and management processes relating to timber truss bridges.	High
	Train relevant Roads and Maritime stakeholders in the use of this CMP.	Medium
	Review the list of bridges to be retained in consultation with OEH, Engineers Australia, National Trust, and other relevant stakeholders.	Very High
	Prepare an Incident Response Plan for each bridge to be retained.	Medium
	Continue to prepare bridge specific CMPs for timber truss bridges to be retained, submit to OEH for endorsement and train staff in use of CMP.	High
	Continue to actively conserve timber truss bridges to be retained by appropriate maintenance, repair and management.	Medium
	Continue to engage with communities to ensure timber truss bridges to be retained are managed in such a way that meets community needs.	High
	Where modifications are required to bridges in order to meet community needs, follow process set out in flowchart provided in Figure 6.3.	High
	Provide Vic Roads and Heritage Victoria with a copy of the endorsed CMP for their information	Medium
Years 2-4	Nominate bridges to be retained to OEH for inclusion on the SHR.	Medium
	Continue to prepare bridge specific CMPs for timber truss bridges to be retained, submit to OEH for endorsement and train staff in use of CMP.	High
	Continue to actively conserve timber truss bridges to be retained by appropriate maintenance, repair and management.	Medium
	Continue to engage with communities to ensure timber truss bridges to be retained are managed in such a way that meets community needs.	High
	Where modifications are required to bridges in order to meet community needs, follow process set out in flowchart provided in Figure 6.3.	High
Year 5	Continue to prepare bridge specific CMPs for timber truss bridges to be retained, submit to OEH for endorsement and train staff in use of CMP.	High
	Continue to actively conserve timber truss bridges to be retained by appropriate maintenance, repair and management.	Medium

	Continue to engage with communities to ensure timber truss bridges to be retained are managed in such a way that meets community needs.	High
	Where modifications are required to bridges in order to meet community needs, follow process set out in flowchart provided in Figure 6.3.	High
	Review this CMP.	Medium

8. References

8.1 Books, technical papers and reports

8.1.1 Heritage Division of the Office of Environment and Heritage

Department of Environment, Climate Change and Water NSW (2010), Code of Practice for Archaeological Investigation of Aboriginal Objects in NSW, Sydney

NSW Heritage Office (1996), *Heritage Curtilages*, Sydney: Harley & Jones

NSW Heritage Office (1998), *How to Prepare Archival Records of Heritage Items*, Heritage Information series, Sydney

NSW Heritage Office (2000), *Natural Heritage Principals, Heritage Information Series*, Sydney

NSW Heritage Office (2001), *NSW Heritage Manual*, Sydney

NSW Heritage Office (2001), *Assessing Heritage Significance, NSW Heritage Manual*, Sydney

NSW Heritage Office (2002), *A Suggested Table of Contents for a Conservation Management Plan that can be Endorsed by the NSW Heritage Council*, Sydney

NSW Heritage Office (2005), *Interpreting Heritage Places and Items Guidelines, Heritage Information Series*, Sydney

8.1.2 Documents written by or for NSW Roads and Maritime Services and its predecessors (Roads and Traffic Authority, Department of Main Roads)

Allan's Calculation Book, held by Bridge Engineering Section of Roads and Maritime Services

Department of Main Roads (1962), 'Longitudinal Sheeting of Timber Bridge Decks', *Main Roads*, Volume 27, No. 4, June 1962, Sydney

Department of Main Roads (1976), *The Roadmakers, A History of Main Roads in New South Wales*, Sydney: Department of Main Roads NSW

Department of Main Roads (1987), *Timber Truss Bridge Maintenance Handbook*, Sydney

GHD (2003), Draft Conservation Management Plan for Victoria Bridge over Stonequarry Creek, Picton dated September 2003 prepared by Austral and GHD for RTA, Sydney

Harrison, B. (1892), A History of the Department, an article for the NSW Department of Motor Transport staff newsletter dated 30 April 1982

KI Studio (2016), *Monkerai Bridge Urban Design Study*, on project file SF2013/077881

KI Studio (2017), *Barham-Koondrook Bridge Heritage Interpretation Strategy & Landscape Design*

MBK, McMillan Britton & Kell Pty. Ltd (1998), *Study of Relative Heritage Significance of All Timber Truss Road Bridges in NSW*, Prepared for RTA, Sydney

McPhail, J. (2005), *Timber/Concrete Composite Module, Testing and Performance*, Roads and Traffic Authority, Australian Small Bridges Conference, October 2005

Roads and Maritime and Futurepast Heritage Consulting P/L (2012), *Timber Truss Bridge Conservation Strategy, Submissions report and revised conservation strategy*, Sydney

Roads and Maritime (2013), *The Old Hume Highway, History begins with a road*, Sydney

Roads and Maritime (2015), *Roads and Maritime Services Cultural Heritage Guidelines*, Sydney

Roads and Maritime (2015), *Movable Heritage Guidelines, Managing moveable objects and collections*, Sydney

Roads and Maritime (2017), *Bridge Inspection Report – Level 2 – Bridge No 965*, on BIS

Roads and Maritime (2016), *Heritage Interpretation Guideline*, DRAFT

RTA (2001), *Oral History Program, Maintaining the Links: Maintenance of Historic Timber Bridges in NSW*, Sydney

RTA (2003), *Southern Highlands Heritage Drives*, Self-Guided tours produced by Roads and Traffic Authority (RTA), RTA/Pub.03.048, March 2003

RTA (2007), *Bridge Inspection Procedure Manual*, second edition, Sydney

RTA (2008), Roads and Maritime QA Specification M757, Timber Truss Repairs – Construction

RTA (2011), *Timber truss road bridges – A strategic approach to conservation*, Sydney

The Blue Book, held by Bridge Engineering Section of Roads and Maritime Services

Percy Allan's Calculation Book, held by RMS Bridge and Structural Engineering, p 18

8.1.3 Other sources

Allan, P. (1895), Timber Bridge Construction in New South Wales, *Journal and proceedings of the Royal Society of NSW*, Volume 29, Sydney

Allan, P. (1896), Lift bridge over the Murray at Swan Hill, *Journal and proceedings of the Royal Society of NSW*, Volume 29, Sydney

Allan, P. (1924), 'Highway Bridge Construction', *Industrial Australian and Mining Standard*, 14/08/24

Allan, P. (1924), 'Highway Bridge Construction', *Industrial Australian and Mining Standard*, 21/08/24

Bowden, J., 'A Bridge Too Far: major shortage of big section hardwoods', *inwood magazine*, Issue 78

- Bowie, I. (2010), 'Australia's First Materials Testing Machine', *ASHET News*, Volume 3, No 4
- Bradfield, J.J.C. (1896), *Some Notes on Australian Timbers*, read before the Sydney University Engineering Society, Sydney
- Broomham, R. (2001), *Vital Connections: a history of NSW roads from 1788*, Sydney: Hale & Ironmonger in association with the Roads and Traffic Authority NSW
- Brown, J. (2012), 'The Howe Truss: From Timber to Iron', *Civil Engineering*, June 2012
- Burke, A.P. (1895) *History of the Colonial Gentry*, London: Harrison and Sons
- Corbett, A. (1979), 'Allan, Percy (1861–1930)', *Australian Dictionary of Biography*, National Centre of Biography, Australian National University, <http://adb.anu.edu.au/biography/allan-percy4996/text8303>, published first in hardcopy 1979
- Cserhalmi, O. (2006), *Pyrmont Bridge Conservation Management Plan*
- Dare, H.H. (1904), 'Recent Road-Bridge Practice in NSW', *Proceedings of the Institution of Civil Engineers* (London), Vol 115
- Department of Public Works (1928) *Contract for construction of a composite truss bridge over Wakool River, at Gee-Gee Crossing, Swan Hill to Deniliquin Road, Specification*, Sydney
- Forrester, R. (2017), Victoria Bridge termite inspection report 17 Feb 2017
- Fraser, D.J. (1985), 'Timber Bridges of New South Wales', *Transactions of Multi-Disciplinary Engineering*, Institution of Engineers Australia, Vol. GE9 No.2
- Fraser, D.J. (1992), *Cowra Bridge – Preservation of a Unique Structure*, Sixth National Conference on Engineering Heritage, Hobart 5 – 7 October 1992
- Fraser, D.J. (1998), Timber Truss Bridges NSW Database, unpublished
- Fraser, D.J. (2003), *Nomination of the Victoria Bridge Picton as an Historic Engineering Marker prepared for the Engineering Heritage Committee*, Engineers Australia, 2003
- Fraser, D.J. (2005), 'The Changeover to American Bridge Technology in New South Wales, Australia – Why 1892?' *Second International and Thirteenth National Engineering Heritage Conference 2005, Sydney, Australia, 21-23/09/ 2005*. Engineers Australia: Conference Papers
- Fraser, D.J. (2010), conference paper, 'American bridges in New South wales, 1870-1932', *Australian Journal of Multi-disciplinary Engineering*, Vol 8, No 1, Engineers Australia 2010
- Glencross-Grant, R. (2012), 'The evolution of large-truss road bridges in NSW, Australia', *Proceedings of the Institution of Civil Engineers, Engineering History and Heritage*, Volume 165, Issue EH2
- ICOMOS (2013), *The Burra Charter: The Australia ICOMOS Charter for Places of Cultural Significance*, 2013
- Kendall, H. (1920), *The Poems of Henry Kendall*, Sydney: Angus and Robertson
- Kerr, J.S. (2013), *Conservation Plan*, 7th edition, Sydney: National Trust of Australia (NSW)
- Lawson, H. (1906), *When I was King and Other Verses*, Sydney: Angus and Robertson

- Mackay, L.H. (1972), *Timber Truss Bridges in New South Wales*, a thesis submitted in partial fulfilment of the requirements for the degree of Bachelor of Architecture at the University of Sydney
- Mackay, R. (1986), 'Conservation and Industrial Archaeology: Recent Work by the National Trust (NSW)', *Australian Historical Archaeology*, Volume 4, 1986
- Maiden, J.H. (1896), 'Timbers of the Colony', *New South Wales: the Mother Colony of the Australias*, edited by F. Hutchinson, Sydney: Charles Potter, Government Printer, Phillip Street
- McQueen, A. (1993), *The Life and Journeys of Barrallier 1773-1853*, Springwood
- Moore, C. (1871), 'On the Woods of New South Wales', *The Industrial Progress of NSW, being a Report of the Intercolonial Exhibition of 1870, at Sydney; together with a variety of papers illustrative of the industrial resources of the Colony*, Sydney: Thomas Richards Government Printer
- NSW Legislative Assembly (1894), *Annual Report of the Department of Public Works*, Sydney
- NSW Legislative Assembly (1896), *Annual Report of the Department of Public Works*, Sydney
- NSW Legislative Assembly (1898), *Annual Report of the Department of Public Works*, Sydney
- NSW Legislative Assembly (1903), *Annual Report of the Department of Public Works*, Sydney
- Palladio, A. (1570), *I Quattro Libri dell' Architettura*, [The Four Books of Architecture]: Venice
- Pope, T. (1811), *A Treatise on Bridge Architecture*, New York: Alexander Niven
- Raxworthy, R. (1989), *The Unreasonable Man*, Sydney: Hale and Iremonger
- Reed, T. T. (1974), 'Kendall, Thomas Henry (1839–1882)', *Australian Dictionary of Biography*, National Centre of Biography, Australian National University, published first in hardcopy 1974:
<http://adb.anu.edu.au/biography/kendall-thomas-henry-3941/text6205>
- Rolls, E. (2005), 'A Land Changed Forever', *In the Living Forest: An Exploration of Australia's Forest Community: Industry, Science, Technology, Government, Tourism, Management, Conservation, Planning*, edited by John Keeney, Sydney
- Trueman, E.G. (1984), *Timber Bridge Conservation in NSW*, Sydney: Hughes Trueman Ludlow
- Tyrrell, H.G. (1912) *Evolution of Vertical Lift Bridges*, Toronto: University of Toronto Engineering Society
- Villy, E. (2017) *Victoria Bridge over Stonequarry Creek at Picton, Historical Background*
- Villy, E., *The Old Razorback Road: Life of the Great South Road between Camden and Picton 1830-1930*.
- Vincent, L. (1995), *The Forgotten Village of Picton, Introducing Upper Picton*, Redbank, Picton

8.2 Newspaper articles (chronological order)

Sydney Gazette and New South Wales Advertiser, Sunday 7 August 1803, p 2

The Sydney Morning Herald, Monday 31 December 1855, p 4

The Sydney Morning Herald, Wednesday 16 May 1860, p 4

The Sydney Morning Herald, 5 August 1882

The Sydney Morning Herald, 31 September 1887

Picton Penny Post, 8 July 1896

Picton Penny Post, 4 November 1896

The Sydney Morning Herald, Friday 8 October 1897, p 5

Picton Post and Advocate, 13 October 1897

South Coast Times and Wollongong Argus, Saturday 13 March 1909, p 4

The Picton Post, Wednesday 14 February 1912, p 4

The Farmer and Settler, Wednesday 5 January 1916, p 7

The Sydney Morning Herald, Wednesday 4 May 1921, p 10

The Sydney Morning Herald, Friday 5 March 1926, p 12

Picton Post, Wednesday 8 September 1926, p 2

The Sydney Morning Herald, Thursday 8 May 1930, p 12

The Sydney Morning Herald, Saturday 13 August 1932, p 9

Picton Post, Wednesday 21 October 1936, p 1

Picton Post, Wednesday 4 November 1936, p 2

Picton Post, 15 November 1951

Picton Post, Wednesday 28 October 1953, p 8

Picton Post, Wednesday 18 November 1953, p 8

Macarthur Chronicle, 14 October 1997

The Sydney Morning Herald, 14 July 2013

Wollondilly Advertiser, Tuesday 13 January 2014

Macarthur Chronicle Wollondilly, 9 September 2016

Abbreviations

Term / Acronym	Description
BIS	Roads and Maritime's Bridge Information System
CMP	Conservation management plan
DMR	NBSW Department of Main Roads (now Roads and Maritime)
Heritage Act	<i>Heritage Act 1977</i> (NSW)
LALC	Local Aboriginal Land Council
LEP	Local Environmental Plan. A type of planning instrument made under Part 3 of the <i>Environmental Planning and Assessment Act 1979</i> (NSW)
MRB	Main Roads Board (now Roads and Maritime)
NAASRA	National Association of Australian State Road Authorities
OEH	Heritage Division of the Office of Environment and Heritage
PACHCI	Roads and Maritime Procedure for Aboriginal Cultural Heritage Consultation and Investigation
PWD	Department of Public Works (now Roads and Maritime)
REF	Review of Environmental Factors
Roads and Maritime	NSW Roads and Maritime Services
RTA	NSW Roads and Traffic Authority (now Roads and Maritime)
SHR	State Heritage Register
SOHI	Statement of heritage impacts
WHS	Work Health and Safety

Appendix A

Schedule of Conservation Works

Table A-1: Works exempt under s57 of the *Heritage Act 1977* not requiring notification to the *Heritage Council* (Policy 16(a))

Element	Works
Site and general	Removal of any rubbish or debris from the site
	Vegetation clearance required to maintain an Asset Protection Zone in accordance with the recommendations of a suitably qualified Bushfire Assessment Consultant accredited by the Fire Protection Association Australia (FPA Australia).
Timber elements generally	Remove any accumulations of dirt or fauna
	Inspect timber and treat active termites
	Check for pain damage, clean and repaint as necessary
	Tighten all bolts
Timber decking	Reseal decking if required
Timber Railings	Check for incident damage, repair as necessary to original detail

Table A-2: Works that may require Heritage Council approval/consent under s57 or s60 of the *Heritage Act 1977* (Policy 16(b))

Element	Works
Bottom Chords	Replace with new bottom chords as necessary
Tension Rods	Reconstruct non-original tension rods with modern steel to original design dimensions and detailing, or consistently upsize all tension rods from original design with steel and preserve representative samples of any original fabric off site
Sway Braces	Replace with new sway braces as necessary
Cross Girders	Replace with new cross girders as necessary
Stringers and Decking	Replace with suitably designed stress laminated timber (SLT) deck
Railing	Install traffic barriers to Australian Standards
Piers	Reconstruct to original design on new piled foundations
Abutments	Replace Abutment A with concrete, replace Abutment B with concrete and stabilise embankment for full length
Interpretation	Install engineers Australia plaque as part of appropriate interpretation

Table A-3: Works that are exempt under this Conservation Management Plan in accordance with Standard Exemption 6 under s57 of the *Heritage Act 1977* (Policy 16(c))

Element	Works
Top Chords	Remove flashing and reconstruct top chords with new timber to original design dimensions and detailing
Principals and Diagonals	Reconstruct principals and diagonals with new timber to original design dimensions and detailing
Cast Iron Shoes	Replace with new ductile cast iron shoes to original design and preserve representative samples of original fabric off site
Visual context and setting	Remove or relocate height restriction portals



rms.nsw.gov.au/



13 22 13



Customer feedback
Roads and Maritime
Locked Bag 928,
North Sydney NSW 2059

January 2018
RMS XX.XXX
ISBN: XXX-X-XXXXXX-XX-X